

Tall Buildings

Structural design of concrete buildings up to 300 m tall

A working group of The Concrete Centre and *fib* Task Group 1.6

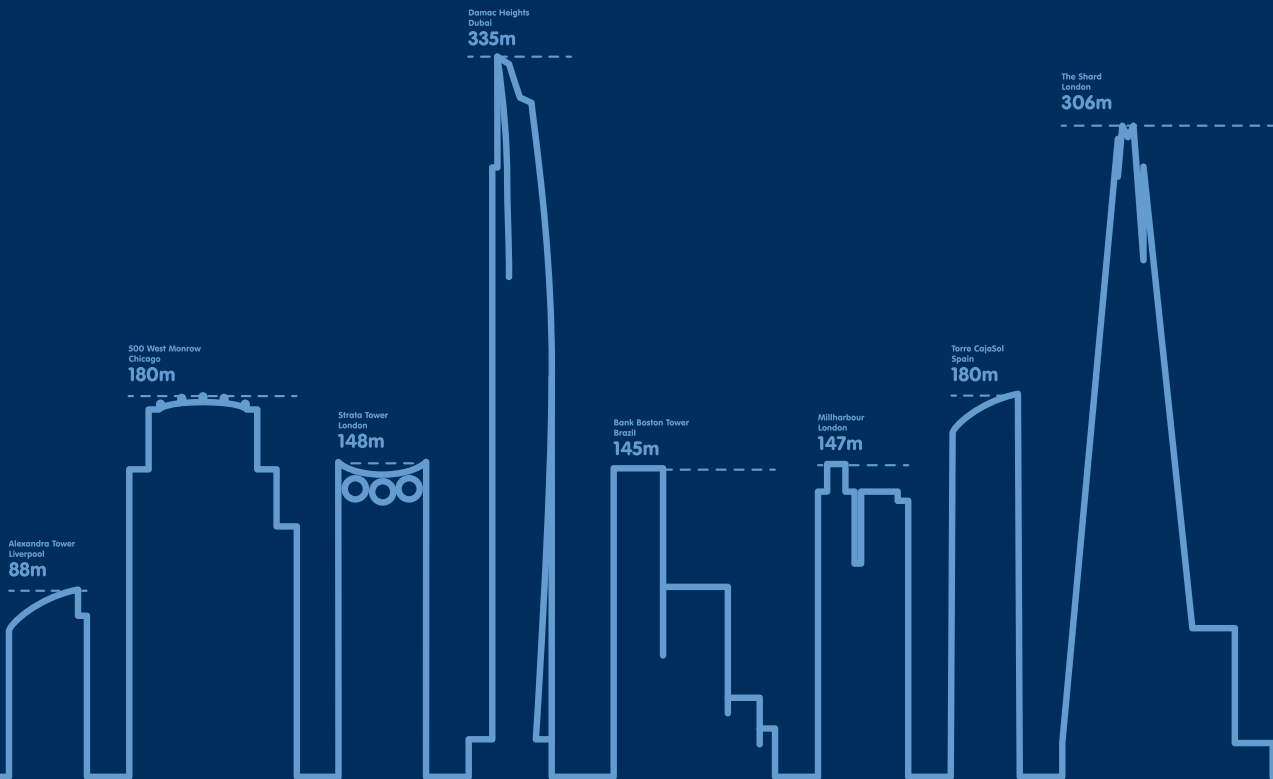

Foreword

Tall buildings are now a common feature on the skyline of many cities throughout the world with concrete as the predominant building material used in their construction. Concrete provides a strong, durable, economic and versatile material which can be engineered to respond to demands placed on it when used in the foundations, columns, walls and floors of tall buildings. The design and detailing of tall buildings requires detailed knowledge, experience and expertise to properly understand their behaviour. Guidance on the design of tall buildings is provided in many of the national codes and standards however as the clients, architects and engineers push the boundaries of what is possible our understanding of the structural behaviour is constantly being updated.

In 2009 the *fib* (fédération internationale du béton) working in collaboration with The Concrete Centre established a Task Group with a mandate to gather the experience and know-how pertinent to the development, design and construction of tall concrete buildings. The findings of the task group are presented in this state-of-the-art report. The report is based on the experience gained by some of the leading individuals and companies involved in the design and construction of tall buildings throughout the world.

The report provides information to engineers who are familiar with the design and construction of low-rise structures and who wish to gain an understanding of the key factors which influence the design of tall concrete buildings.

Andy Truby
Convener, *fib* Task Group 1.6

Acknowledgements

The Task Group would like to acknowledge the support of:

The authors and their respective companies; Claire Ackerman and Jenny Sheerin, The Concrete Centre (editing and production); Alyson Magee (editing); The Concrete Society (production); Stephen Blundell (writing and technical expertise); Alan Mann (technical expertise) and all the members of the working group (full list on inside back cover).

Published by MPA The Concrete Centre and Fédération internationale du béton (*fib*)

Gillingham House, 38-44 Gillingham Street, London SW1V 1HU

Tel: +44 (0)207 963 8000

www.concretecentre.com

CCIP-058

Published September 2014

ISBN 978-1-908257-14-7

Price Group R

© MPA The Concrete Centre and Fédération internationale du béton (*fib*)

Cement and Concrete Industry Publications (CCIP) are produced through an industry initiative to publish technical guidance in support of concrete design and construction.

All advice or information from MPA -The Concrete Centre is intended only for use in the UK by those who will evaluate the significance and limitations of its contents and take responsibility for its use and application. No liability (including that for negligence) for any loss resulting from such advice or information is accepted by Mineral Products Association or its subcontractors, suppliers or advisors. Readers should note that the publications from MPA - The Concrete Centre are subject to revision from time to time and should therefore ensure that they are in possession of the latest version.

Tall Buildings

Contents

1. Introduction	1
2. Structural design strategies	3
3. Structural framing systems	14
4. Structural elements	25
5. Foundations	39
6. Buildability	48
7. Loading	58
8. Building dynamics	66
9. Wind engineering	74
10. Seismic engineering	86
11. Time-dependent behaviour	106
12. Materials	124
13. Structural design	129
References	141
14. Case Studies	145

1. Introduction

Tall buildings present unique challenges in terms of both design and construction. Their sheer scale demands that particular attention is paid simultaneously to strategic and detailed issues. Tall building design and construction requires an integrated approach, with the need for various engineering disciplines to coexist efficiently from the beginning of the project. This multi-disciplinary approach extends to consideration of how the building will be constructed, and thus ideally involves an integrated team (including construction and design professionals) at the earliest stage of the project.

The definition of 'tall' for a building is not absolute. It is understood here as when the geometry of the building, for example overall height or height-to-minimum-plan dimension, significantly influences aspects of the design. These aspects are:

- structural lateral strength and stiffness
- vertical transportation
- fire escape
- services distribution
- vertical building movement (shortening)
- setting-out and verticality
- hoisting of materials.

One definition is that if the building aspect ratio, height divided by lowest overall lateral dimension, is more than 5:1, then the building may be considered tall.

For consistency, this document will refer to tall buildings in preference to other common terms including 'skyscraper', 'high-rise' or 'tower', with the exception of sections describing historical context. The term 'tall' may also be sub-divided as follows:

Table 1.1
Definition of 'Tall'^[1]

Use (approx. storey height)	Tall	Super-tall
Residential (3.0 m)	Up to 100 storeys (300 m)	Over 100 storeys (300 m)
Office (4.0 m)	Up to 75 storeys (300 m)	Over 75 storeys (300 m)

The following chapters provide guidance and insight into the design challenges and considerations relating to the design of 'Tall' buildings formed in concrete. Some guidance is provided for buildings in the 'Super-tall' range; however, it is recommended that readers interested in 'Super-tall' buildings research this subject further using the references provided throughout this document.

Historic precedents

The word 'skyscraper' originated as a naval reference to the tallest mast or main sail of a sailing ship. Tall buildings were in evidence around the globe long before the term was first applied in the late 19th century.

The highest of the Pyramids of Giza, built circa 2500 BC using rudimentary technology and manpower alone, still stands at 146.6 m and was not surpassed until the 14th century, with the construction of Lincoln Cathedral in England.

The earliest known examples of urban living based on vertical or tall construction are the many (around 500) 'tower houses' built in the 16th century to protect the inhabitants of Shibam in Yemen from Bedouin invaders. Often called 'the oldest skyscraper city in the world', the mud towers range from five to 16 storeys, reaching heights of up to 40 m and accommodating one or two families on each floor.

Examples are profuse across Europe, from masonry towers in Bologna dating from the 11th century onwards and reaching heights of 97 m, to the 11-storey, stone-built structures of Edinburgh constructed upwards in the late 17th century in response to the confines of the defensive stone walls of the Scottish city's boundary.

Post-Industrial Revolution advances in building technology saw the construction over 1884-1885 of the 10-storey Home Insurance Building in Chicago, generally considered to be the first modern skyscraper. Its design pioneered the first load-bearing structural frame, a construction type later known as the 'Chicago Skeleton'. This revolutionary concept, whereby individual framing elements, rather than walls, carry the entire building load, is regarded as the antecedent to our current ability to conceive and construct buildings truly warranting the term 'tall' or 'skyscraper'.

Earlier in the century, Joseph Monier had invented reinforced concrete, using metals – originally iron but latterly steel – cast into fresh concrete. In 1867 it was patented and exhibited at the Paris Exposition. The devastating 'Great Chicago Fire' of 1871, meanwhile, not only prompted a rewriting of statutory fire regulations but revealed strong evidence of the inherent fire resistance of concrete as a structural material in tall buildings.

By the early 20th century, the skyscraper was becoming the most prominent and progressive building type, aided by innovations such as mechanical lifts, the telephone and central heating systems. Urbanisation and increasing wealth had further boosted prospects for the proliferation of tall buildings.

The Ingalls Building (1903) in Cincinnati, Ohio, with its 15-storey monolithic frame, standing at 64 m tall, was the first reinforced concrete skyscraper.

Today, concrete is firmly established as one of the leading tall building construction materials. Enhanced construction techniques, dramatic increases in concrete and embedded steel strengths, and recognition of inherent properties such as natural damping, fire resistance and sound insulation have all contributed to longevity in its use. Indeed, today the tallest buildings are built almost exclusively with reinforced concrete.

2. Structural design strategies

Tall building design involves all of the design interfaces present in low-rise construction but there are also a number of key additional factors which designers must consider. This is particularly relevant for structural engineers but equally so for clients, architects and building services engineers. In addition, the design development is likely to involve input and collaboration from other specialists, including:

- Façade engineers
- Wind specialists
- Geotechnical specialists
- Seismic specialists
- Fire consultants
- Lift specialists
- Construction advisors.

For a design to be effective and economic, it is essential that all disciplines work holistically and gain a good understanding of the critical factors which have an impact on the associated disciplines.

The following sections give an overview of the various elements structural engineers need to be aware of when embarking on the design of tall buildings. Further detail is provided in subsequent chapters. The reader will however need to research the various topics in more detail using the references provided throughout this document.

Choice of structural system is fundamental to planning buildings and must be considered at the outset. One of the main factors in the design of tall buildings, and the key difference from the design of low-rise buildings, is the influence of lateral loading.

For low-rise construction, measures to resist lateral loading are well understood by most designers and include well-positioned stiff vertical elements working in conjunction with horizontal diaphragms or braced panels. Such provisions, in conjunction with the provision of vertical and lateral ties for robustness, produce safe solutions which have stood the test of time.

For tall buildings, the relative magnitude of lateral loadings to gravity loads generally increases significantly, just by virtue of building height. Wind loadings tend to increase with height from the ground which, combined with the large face area of a tall building and lever arm to the ground, serves to produce the dominant load case and hence govern the design and sizing of many of the main structural elements, particularly core walls and columns.

Additionally, in tall buildings, lateral displacement or drift must also be calculated and may need to be limited. Excessive lateral displacement could potentially affect finish, internal partitions and external cladding, particularly if the inter-storey drift (lateral displacement over one storey) is too high.

2 Structural design strategies

The dynamic performance of tall buildings must be considered in detail. Loading from wind and seismic actions occurs across a broad spectrum of frequencies and the response of the building will be influenced by its natural frequency and the degree of inherent damping. Where the natural frequencies of the building are close to the frequencies of applied loadings there is a risk that the response is amplified, resulting in increased loadings and movement. This mechanism requires detailed consideration by the structural engineer to investigate the performance of the structure across the full frequency spectrum of the applied loadings. If accelerations associated with any movement are excessive, building users could potentially experience motion sickness.

In regions of the world subject to earthquakes, the response and performance of buildings during such events is also a critical design consideration.

2.1 The slenderness ratio

At the initial planning stage, it is advisable to consider the basic proportions of the structure. The slenderness ratio (SR) can give a good initial indication of how hard the structural system will need to work. The SR is obtained by dividing total building height by the smaller base width. SRs of around $H/6$ or less can usually be accommodated whereas for $H/8$ or above the structural system will be working harder and the dynamic behaviour is likely to be dominant in the structural solution.

The SR should, however, only be used as a guide to the potential behaviour of tall buildings. The following sections discuss the stability of tall buildings in more detail, and present a number of stability systems which can be used. As will be shown, the actual behaviour of the tall building is more closely related to the ratio of building height to the smaller dimension of the stability system.

Figure 2.1
Diagram of slenderness ratio.

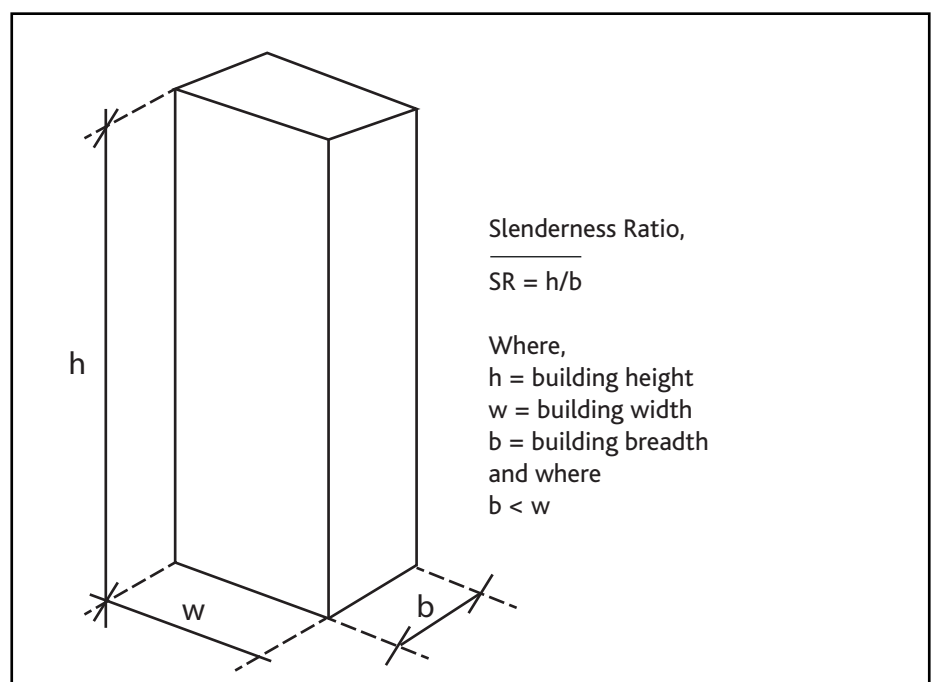

2.2 The structural system

To provide a structure with both the strength and stiffness to resist large lateral loadings and limit drift movement and excessive accelerations, designers must carefully consider the structural framing system (of which the building core will often form a major part). Structural framing system types are detailed in Chapter 3.

It is essential for engineers to explain the fundamental aspects and behaviour of the selected structural system to other members of the design team and discuss the interfaces with other disciplines. Such discussion and explanation will allow further optimisation of the structural solution, for example, by combining structural zones with plant-room requirements.

It is good practice for the engineer to prepare a summary, in text and simple sketches or possibly 3D model shots, of the selected structural system as part of the design documents. This not only is an aid to the contractor and other major stakeholders, but is also a concise way of showing that, as designer, you fully understand and, more importantly, can show others the way the structure works.

2.3 Building services coordination and integration

Structural engineers need to work closely with other disciplines to achieve a truly integrated and holistic design. With regard to building services, a number of factors impact on the design of mechanical and electrical facilities and require different solutions than those applicable to low-rise structures.

Crucially, tall buildings require the distribution of services vertically over a significant height.

Water services cannot always be sufficiently high-pressurised to be pumped the full height of a tall building. This frequently means that water storage tanks are required at intervals of every 30 floors or so up the height of the building.

Electrical services can be inefficient in distributing at low voltage over heights of more than 100 m. Often, this means that high voltage primary distribution is used, requiring the incorporation of electrical substations within the height of the building.

Ventilation providing fresh air to the building can require the movement of large air volumes requiring very large ductwork sizes and associated plant. To keep duct sizes down to a reasonable size, the air systems are often split into zones, thus requiring multiple plant rooms distributed up the building.

Data distribution requires hubs to be provided at perhaps 90 m intervals up the building, connected by fibre optic cabling.

Multiple plant spaces are a common requirement of tall buildings and are often accommodated at ground/basement level and at the top of the structure in buildings up to 200 m tall. For taller structures, plant rooms may also be required at intermediate levels. Where the building has mixed uses, for example, office and hotel/residential, the services to each use will need to be split to ensure that supplies are independent of each

other. Also plant rooms will need to be provided close to the relevant section of the building. For this reason plant spaces are frequently introduced at intervals up the building to match the levels where use changes. From a structural engineering perspective, such plant spaces can be useful in offering the opportunity to introduce additional structural elements and thus provide increased strength and stiffness.

It is essential for structure engineers to understand the engineering philosophy for each of the mechanical and electrical systems, and contribute to solutions accommodating these requirements so as to conform to structural engineering requirements.

2.4 Façade engineering

The type of façade system adopted is very much dependent on the aesthetic requirements specified by architects, as well as the structural design of buildings. However, there are some additional issues prevalent in tall buildings which should be given close attention.

Difficulties can arise at the interfaces between disciplines and, indeed, the actual interfaces of elements relating to junctions and tolerances. The construction strategy greatly influences these details and vice versa. The following aspects affect façade engineering of tall buildings and must be taken into account:

- Achieving planning permission – height constraints
- Technical – code compliance
- Commercial – budget certainty and perception of risk
- Programme – construction and procurement strategy
- Performance – especially energy efficiency
- Occupant comfort – including ventilation strategy, daylighting
- Lettable area.

Movement, both horizontal (shear and bending) and vertical shortening, of tall buildings can influence the jointing provision between panels, particularly at transfer levels in the structure. The movement to be accommodated in the stack joint at such locations is primarily due to differential vertical movement between floors and the effects of axial shortening.

The mid-level of tall buildings and returns in the tall building envelope are vulnerable to high wind pressures and driving-rain ingress, requiring the design of exterior walls to buffer these adverse conditions and prevent unwanted air and water infiltration. A full regime of testing is normally performed on prototype mock-up specimens prior to full-scale production of the system.

Mechanical systems can also greatly affect the façade and vice versa. Natural ventilation and domestic windows are not suitable for high-rise construction.

When installing the façade of tall buildings, there are advantages to be gained from systems that require lightweight cranes and hoists, as the use of tower cranes would conflict with construction of the main structure.

In dealing with potentially high cladding pressures, the main structure's fixing system should be easily installed and compatible with the structural floor system. The fixing system must also allow for relatively fast installation of panels, as all other trades depend upon closure of the building by the exterior wall system.

The above considerations must be considered early in the design process and require agreement and collaboration between all the design disciplines and the constructor. Specialist input from a façade engineer is recommended at the early design stage.

2.5 Planning the core

The core of a tall building is arguably the most fundamental and important element under consideration during the design process. The core will generally house all elements of vertical distribution within the building and be used daily by every user of the building. For most tall structures, the core will form the main backbone of the building and play a significant role in carrying a large proportion of vertical loading and, frequently, the majority of lateral loading.

An inefficiently planned core will lead to slower construction, lower quality and wasted floor area, all of which increases cost.

When planning the core layout, designers must consider many factors which interact and influence each other. Structural engineers should work in close harmony with architects, building services engineers, fire advisors, lift specialists and clients. In addition, the construction methodology must be considered from the outset, as one of the key elements in the viability of a tall building is its speed of construction.

Shear wall structural systems

For a shear wall structural system, the core shear walls are generally provided around the perimeter of the core area to encompass lift shafts and lobbies, staircases and primary vertical services shafts. For maximum structural efficiency, core walls should be as long as possible and, ideally, symmetrically placed relative to centre lines of the building.

Core wall thickness

While core walls are sized to resist applied loadings, wall thicknesses may vary between 350 mm and 600 mm or more for buildings up to 200 m tall. Such wall thicknesses may be unfamiliar to design teams not used to designing tall buildings and it is important, therefore, for structural engineers to make an early estimate of wall thickness and thus allow architectural planning of appropriate structural zones.

Maximising vertical loading

The layout of the structure immediately outside the core can also impact its performance. To resist applied lateral loads and resultant overturning, the design should maximise vertical loading carried by the core, as this provides a restoring moment and helps resist tensile forces produced by the overturning moments. In planning its layout, the structural efficiency of the core - and hence overall design - is helped greatly if the column arrangement outside the core is such that floor spans onto the core walls are maximised.

Positioning of service risers

For low-rise construction, it is common to position service risers close to the lift or stair cores. This is sensible as such cores are generally distributed around buildings at intervals to suit the escape travel distances and access every floor, generally at a corridor position. This is compatible with normal requirements and routes for distribution of mechanical and electrical services.

For tall buildings, this logic is often carried across from low-rise construction and can be appropriate but there are some major additional considerations. Tall buildings are likely to require the provision of fresh air and, thus, large duct and riser sizes. Providing this space within the core can reduce its efficiency. Furthermore, core walls will have to be penetrated to pass any ductwork and services through from inside the core to the floor plates. Such penetrations can be large, reducing the stiffness and capacity of the core walls significantly while also being difficult to form during construction, thereby complicating the detailing and speed of construction.

Service riser shafts are thus sometimes positioned immediately outside the core, eliminating the need for core wall penetration whilst maintaining locations and access to, for example, corridor zones. However, the transfer of vertical and lateral loads from the floor slabs is also very important to the overall structural system, and it must be ensured that such load transfer is not compromised by positioning large openings at key zones. Where service openings are required through the core walls, they should be positioned at mid-length along the core and avoid the highly stressed areas at the ends and corners of core walls.

2.5.1 Effect of building usage

Type of usage can greatly affect the core design and hence the overall design, cost and efficiency of buildings. Tall buildings generally have four main uses:

- **Residential** usage is generally in the form of apartments with one or two bedrooms or perhaps a few larger apartments or penthouses. Each apartment will contain living space, a kitchen and bathrooms, with the layouts generally repetitive between floors. Acoustic separation between floors, and between apartments, is a key design consideration. Often two-storey (duplex) apartments are also provided, necessitating the introduction of relatively large openings in the intermediate floors to allow for staircase access between floors.
- **Hotel**-usage floor layouts above the main reception area and function rooms or dining spaces generally comprise repetitive en-suite bedrooms spaces. Hotel rooms also require a good degree of acoustic separation.
- **Commercial** usage tends to entail large open spaces to allow flexibility for office layouts.
- **Retail** usage is generally contained within the lower floor levels of tall buildings, perhaps in podium structures. They too require large open spaces, and may also require larger floor-to-ceiling height and, potentially, larger ceiling zones.

Although the use can introduce its own design requirements for layout, floor-to-floor height and acoustic separation, the major design factor is occupancy rate. For example, looking at a typical tall building with a floor area of around 1000 m² (net):

- Occupancy per floor would range from 20-30 people for residential usage, 35-40 people in a hotel and as many as 80-120 occupants in an open-plan office. Thus, for a 40-storey building, total occupancy could range from 800 people in a residential building to over 4,000 people for commercial usage.
- The impact on lift strategy is significant and, in the case of commercial usage, would result in increased demand for lifts around peak usage times coinciding with the arrival and departure times of office workers. For the example given, the number of lifts required could vary between three and ten, depending on the lift speeds and car sizes used.
- Often a mixed-use building may be proposed and, while this can offer some economy, there is often a need for dedicated lifts for each 'use' for reasons of security and occupant separation.

Residential usage, including hotels, frequently require floor plates to be split by robust walls, which can provide both acoustic and fire separation. In such cases, it may be possible for the structural form to utilise these walls as part of the stability system and thus produce an efficient structure. The live loadings for residential usage are similar to those for low-rise buildings and can be relatively low. However, due to requirements for the separation of spaces, the dead loading from dividing walls can be relatively high.

For office and retail usage, there is generally a desire to provide clear open spaces offering flexibility of layout for the users. Such arrangements preclude the adoption of cross wall stability systems. Design live loadings are generally higher than for residential uses.

2.5.2 Typical layouts

The layouts of tall buildings vary to suit the particular requirements of any given project and are influenced by the available site footprint, adjacent structures and planned use. The following layouts show a number of arrangements covering residential, commercial and mixed usage. Further layouts are provided with the case studies contained in Chapter 14.

2 Structural design strategies

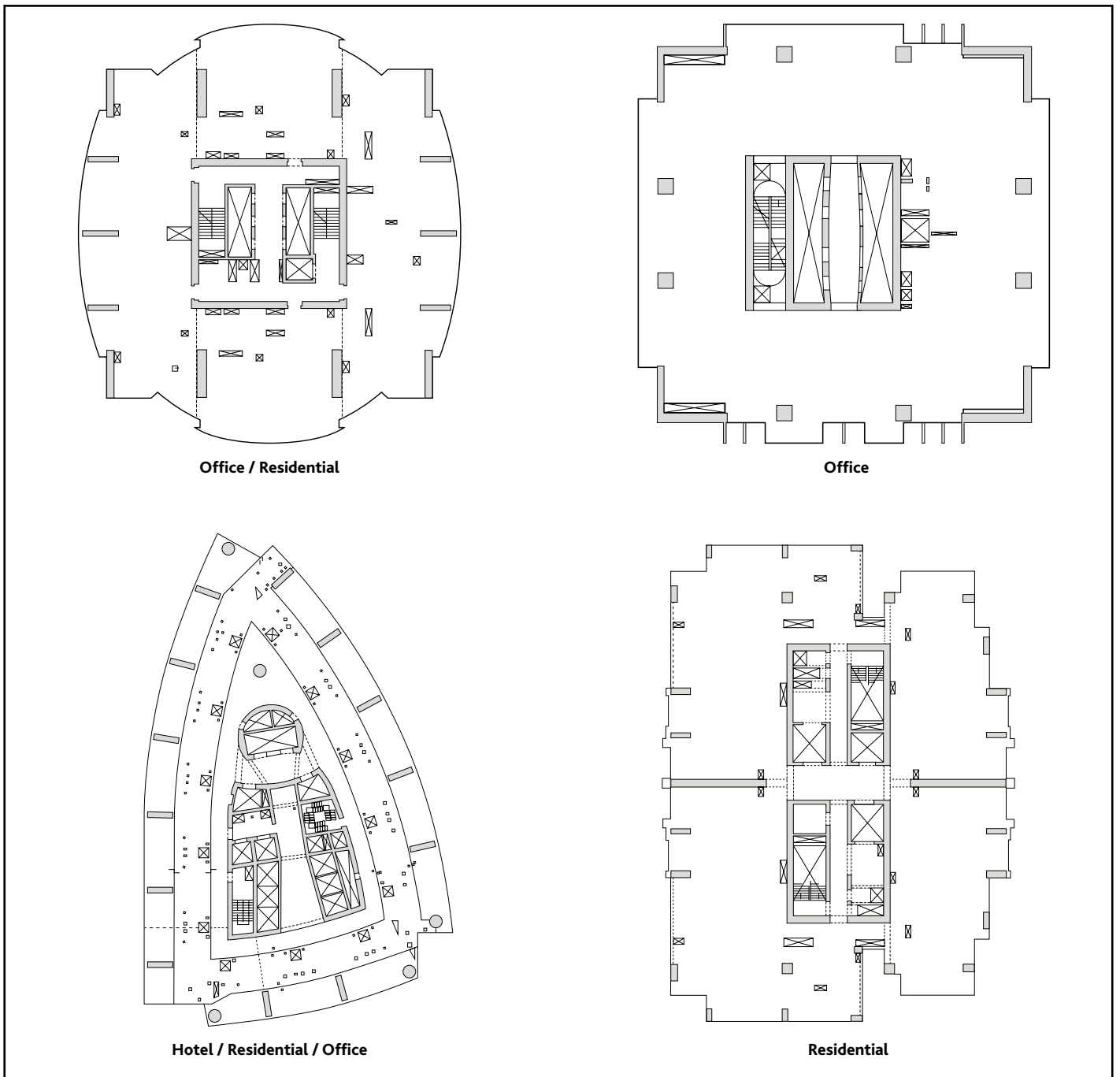

Figure 2.2
Typical building plan arrangements.

2.6 Vertical transportation

The core provides the main access point for all users of the building and generally houses all vertical access systems, namely, lifts and stairs. At the scheme design stage it can be beneficial to take advice from a specialist in vertical transportation. It is essential for movement patterns, occupancy rates and waiting times, for example, to be considered in selecting the optimum number of lifts, lift sizes and other specifications.

A number of lift strategies are viable to optimise lift provision, such as the provision of two lift cars operating independently within a single shaft or double-decker lift cars serving either odd or even floors respectively; however, these systems can be expensive and are not that common. For very tall buildings, express lifts transport users to a sky lobby where slower lifts then take them to their required floor, which could be above or below the sky lobby level.

More sophisticated systems are also available which monitor lift patterns and allow users to preselect their destination, either directly or via automatic monitoring of ID swipe cards; the system then directs users to the fastest lift. Such systems can reduce the number of lifts required within buildings, saving valuable space within the core, but should be investigated and incorporated at the right stage in the process or some of the benefits may be lost.

Calculating the required lift movements and specifying the lift speeds is a specialist area and advice should be sought from a lift specialist at an early stage in the design process.

2.7 Fire requirements

In planning the layout of tall buildings, fire escape requirements must also be considered early in the process, with space provisions incorporated into the core layout. The escape strategy is key to many aspects of the design, including:

- Location, size and number of escape stairs
- Width and details for escape stairs
- Need for sprinkler systems
- Requirements for wet/dry risers
- Provision and requirements for fire-fighting lifts/shafts
- Compartmentation, fire door and escape lobby requirements
- Smoke control provisions.

All these factors can impact on subsequent design activities, and therefore early specialist advice is required to avoid abortive work.

It is also important to get confirmation of the recommended minimum fire resistance period, which for superstructure elements is usually 90 minutes but which may be longer for certain building uses or certain areas of the buildings, for example, the basement.

2.8 Buildability

Speed of construction can be paramount to the viability of tall buildings. With the capital cost representing a huge investment for clients and developers, obtaining a return on investment is usually a key driver.

The core area represents a significant proportion of the building footprint. The core usually lies at the heart of the construction site and will inevitably be used in some way for vertical access during construction. Designers must consider, therefore, how the core can be constructed quickly and efficiently. In modern construction, most contractors will cast the core walls using either slip-forming or jump-forming techniques [2]. The layout of the walls can be affected by the casting technique adopted.

Other elements of the structure must also be designed to allow efficient and quick construction. The cycle time from floor to floor can greatly affect the overall construction programme. Designers must, therefore, carefully select the form of columns, walls and floors and consider the method of construction. Ideally designers should obtain specialist construction advice.

Buildability is discussed further in Chapter 6.

2.9 Building drift and dynamic behaviour

Tall structures will inevitably deflect laterally (drift) under the effects of wind and seismic loads. Designers typically set limits on the magnitude of these drift deflections and often quote these in relation to the overall height, h . An overall drift limit of $h/500$ is typical, however, the movement of one storey relative to the next (the inter-storey drift) is also important in the design of the cladding system. Values for the inter-storey drift in the range of $h/500$ to $h/200$ have all been used successfully in the past and $h/300$ probably strikes a good balance, while $h/400$ is easier for cladding suppliers to deal with.

Although the drift values give an indication of performance the more important factor is the dynamic response of the structure and designers must have a sound understanding of the dynamic behaviour. A key factor affecting dynamic behaviour is the degree of damping inherent in the structural form.

All buildings respond dynamically to changing load. A building has natural frequencies, with associated mode shapes, at which it will respond when excited by changing loads. For static loadings, such as those resulting from gravity, the natural frequency of response has no effect on the loadings and displacements of the structure. However, for dynamic loadings such as those induced from wind and seismic action, the natural frequency of the structure needs to be considered. Where the frequency of the loading is close to the natural frequency of the building's response, a resonant displacement build-up can be induced which will magnify the forces and displacements.

Tall buildings formed of in-situ reinforced concrete do, however, have an inherent degree of natural damping. Damping, which is a measure of a structure's ability to dissipate energy, has a significant effect on the dynamic performance of buildings and limits resonant displacement build-up under repeated wind or seismic loading.

Damping values are typically quoted as a percentage of critical damping, which is defined as the damping required to bring the motion to rest after one cycle. As energy dissipation comes about as a result of cracking, applicable damping values are also linked to operating stress values in the structure and thus may be typically higher under extreme seismic action than under serviceability states of wind or seismic loading. This relationship makes the structural engineering design somewhat iterative.

Natural damping values cannot be altered other than by accepting increased cracking levels and, as they are uncertain in magnitude, the output of dynamic analytical models will also be uncertain. While it is possible to add damping to a structure by various mechanical means, this can have practical and cost drawbacks. It is recommended that the dynamic performance of buildings is investigated at the early design stages using a range of damping values to establish the sensitivity of the response. Such modelling is particularly important for slender towers.

Early identification of resonance problems will allow time to either modify the structure or determine if some form of additional damping or energy dissipation system is required. If required, the practical aspects of accommodation and costs can be included within the overall plan. The use of auxiliary damping, if required to satisfy serviceability limit states, must be reviewed in the context of building form and construction and maintenance budget, so as to balance client aspirations with functionality and serviceability.

For further information on building dynamics, refer to Chapter 8.

2.10 Accidental damage

The overall aim of designing tall buildings to withstand accidental loads is similar to that for all buildings, in that the structural system devised by engineers must maintain a level of service or stability after the occurrence of an accidental event, such as an impact, explosion or consequence of human error. This will require the structure to have redundant load paths and adequately proportioned tie forces for robustness. As with all structures, it is crucial for the structural system to be arranged to avoid disproportionate or progressive collapse. More importantly, structural integrity will depend on the maintenance of an adequate load path ensuring that all of the loads, including accidental combinations, are transferred to the foundations after an accidental event. Accordingly, a structure should have sufficient redundancy or multiple load paths.

Tall buildings constructed with a central concrete stability core surrounded by an in-situ reinforced concrete frame have good inherent robustness against a major impact or event. A number of factors contribute to this. Reinforcement provides good continuity, holding the frame together, while the mass and capacity for plastic deformation provide a high level of energy absorption. Good inherent fire resistance is also a major benefit. Concrete columns designed for significant axial loads will generally be found to resist the standard impact loads specified in design codes without any special treatment.

For further information on accidental loadings, refer to Chapter 7.

3. Structural framing systems

Selection of the most appropriate structural system for tall buildings depends on many factors including, but not limited to, geographical location, construction skills, building height, plan dimensions and intended use, as well as preferred visual appearance and architectural requirements. The full complement of parameters is outside the control of structural engineers.

Tall concrete framed buildings will almost always rely on the lift and stair core for a large proportion of their lateral stability and overturning capacity. Structural engineers need to pay particular attention to the position, size and arrangement of the core. Centrally located cores are preferred but are not an absolute requirement. Positioning the core too far from the centre of a building plan may necessitate the use of other lateral stability systems to resist building twist.

All of the systems outlined below are based on the use of conventional cast in-situ technology, excluding auxiliary damping systems used to control movement and acceleration. For cases requiring an increased level of occupant comfort, various aspects of the building performance can be improved with the use of auxiliary damping systems. See Section 8.1.

Khan's Structural System Chart – The introduction of a framed tube structure by Fazlur R. Khan (1929–1982) in the 1960s, together with industry-wide development in understanding the range of structural behaviour appropriate to tall buildings, was a major contribution to the evolution of skyscrapers.

Khan's motto was 'the structural system is dictated by the structural logic' and he transformed the high-rise building design process, developing a Structural System Chart for tall buildings (see Figure 3.1 – although not all systems shown are appropriate for reinforced concrete framed buildings or within the height scope of this publication).

Development of this wide variety of structural typologies has allowed modern engineers to develop their designs with more clarity. Virtually all contemporary tall buildings will have a structural system recognisable in the Structural System Chart.

For most tall buildings, system combinations may be applicable and engineers should allow reasonable time to determine the most appropriate structural system for each case. This task becomes easier with experience and is often based on a process of elimination.

Figure 3.1
Structural System Chart, first proposed
by Fazlur R. Khan.
 Image: Provided by permission of SOM.

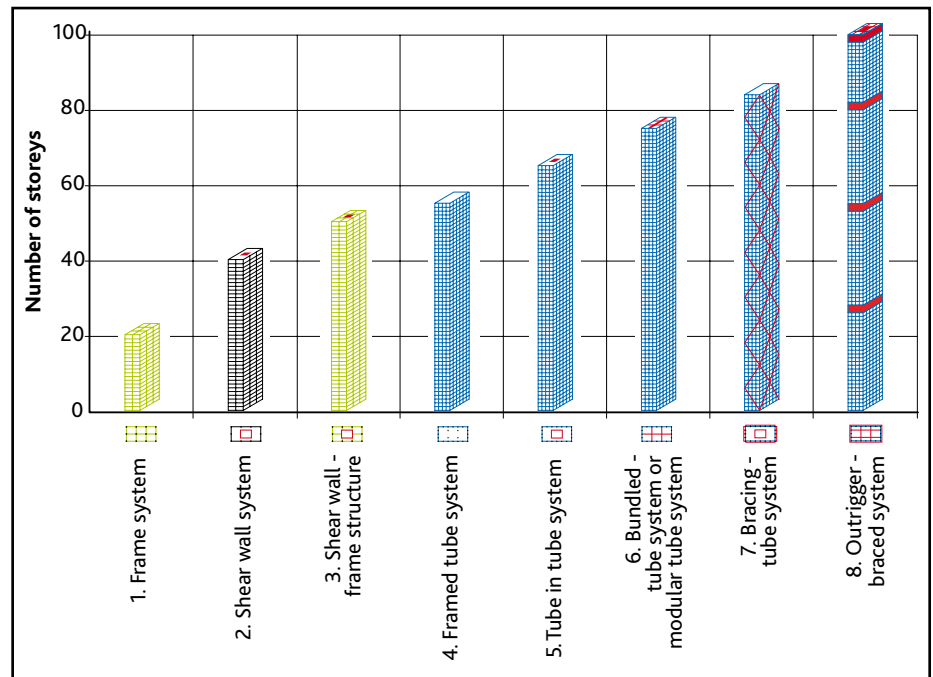

3.1 Framing systems

This section explains the structural principles and significant aspects for each of the framing systems. At some building heights, there will inevitably be a crossover in the structural performance of adjacent framing typologies, leaving final decisions to the judgment of structural engineers who consider cost and efficiency.

For buildings at the taller end of the scale (above 200 m), some of the structural systems will have a significant impact on the aesthetics of the building and, consequently, may require far greater collaboration with the architects.

Type 1 – Frame system

This is a relatively simple structural system, in which beams and columns are rigidly connected to form moment-resisting frames in two orthogonal directions resisting lateral and gravity loads.

Each frame resists a proportion of the lateral load, determined on the basis of its relative stiffness compared to the sum total stiffness of the frames. For increasing structure height, there is an associated direct increase in the size of the frame elements to satisfy lateral drift and deflection limits.

The most economical arrangement, ensuring a relatively easy construction method, is the flat-slab rigid-frame structure. The spans and floor-to-floor heights, and therefore flexural stiffness of the rigid frame members (flat slabs, columns and connections) govern the lateral stability of the entire structure. Typically, the most economical flat slab span is the range of 8-9 m, but this will also depend on the building and floor heights.

3 Structural framing systems

A great advantage of the in-situ reinforced concrete moment-resisting frame system is the inherent continuity of the concrete, and consistently determinable stiffness of the structural members and joints.

This structural system is applicable for buildings of up to approximately 75 m in height.

Figure 3.2
Type 1 - Frame system.

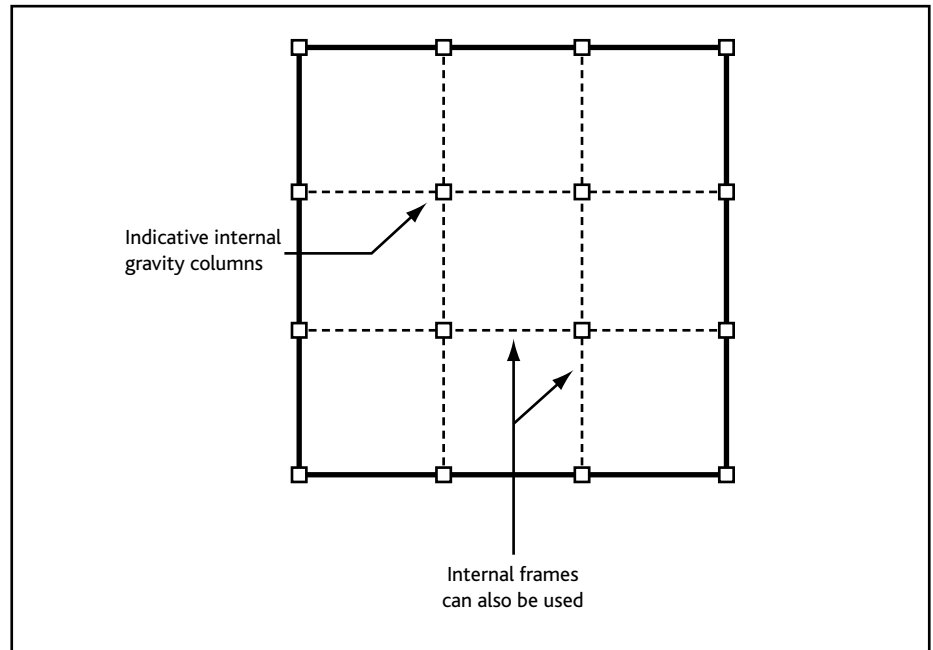

Type 2 – Shear-wall system

This system consists of shear walls designed to resist lateral forces in two orthogonal directions. Figure 3.3 shows a typical arrangement, with shear walls arranged near the centre of the structure to house lifts, fire-escape stairs and other building servicing, thus providing a stiff structural spine to resist horizontal loads in two directions. This is often termed a 'core system', with the core designed to act as a single vertical cantilever with sufficient lateral, torsional and bending stiffness to resist the worst combinations of service and ultimate conditions.

A variation on this system involves the dispersal of additional shear walls evenly throughout the plan area of the building. If this layout is adopted, it is beneficial to attain a level of symmetry in the wall dimensions and positions across the plan to mitigate building twist.

Particular attention should be given to cores positioned away from the geometric wind centre or the seismic mass centre of the building, in one or both directions. In this case, the torsional or twisting loads on the core should be accurately determined and designed for.

Pure central core systems. In this instance, the walls act as vertical cantilevers transferring horizontal loads to the foundations through flexural action and base shear. For this framing typology, the very large relative lateral stiffness of the walls, compared

to the remaining vertical elements (columns), ensures lateral loads are resisted entirely by the main shear walls. The columns are then designed to resist gravity loads only, simplifying the design process and flat slab construction.

Architectural requirements and the need to run mechanical and electrical duct work from within cores to floor areas usually leads to repetitive wall and opening arrangements. This can result in effectively separate banks or groups of shear walls in the same plane, which are separated by some distance, such as a lift-lobby corridor. It is common in high-rise construction to connect these walls by stiff slabs and link beams at each floor level. This creates what is known as a 'coupled wall' structure and achieves a much greater flexural stiffness than separate core wall elements.

Tying multiple parts of a core together with link beams can result in a 'doubly curved' deflection profile within the core alone, similar to that shown in Figure 3.5.

The shear and moment that will occur in these beams, will usually make design and detailing more complicated, particularly where the beams are slender or shallow, but the advantages for the deflection performance of the structure are considerable.

Application of this system (and indeed any system where large structural elements are tied together to achieve much greater bending stiffness) can result in large tensile forces at foundation level, as a result of the base overturning moments from the peak lateral load combinations. It is essential for the shear-wall layouts to be planned and arranged for overall stability, in balance with gravity loads.

This system is generally sufficient for buildings up to 120 m tall. Although making shear walls larger and longer within the limits of the floor plan may achieve significantly greater heights (well into the 'super-tall' category) other systems may prove more economical.

Figure 3.3
Type 2 - Shear-wall system.

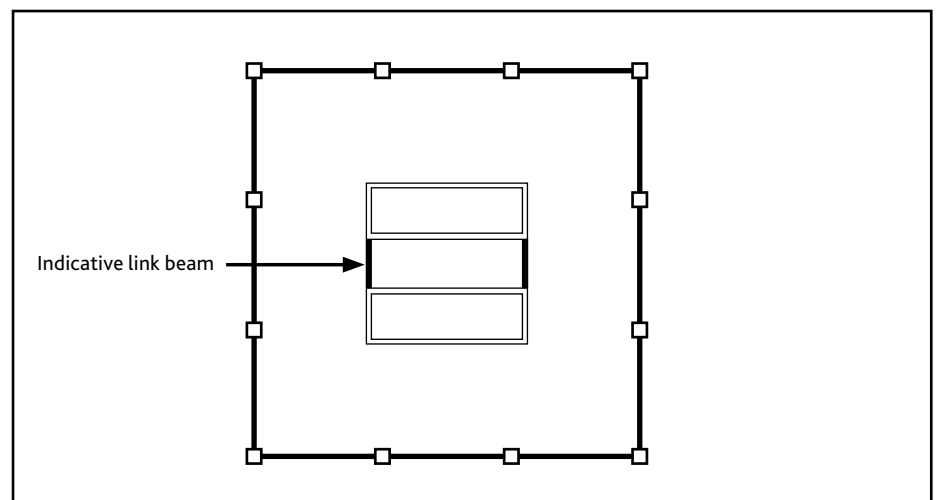

3 Structural framing systems

Type 3 – Shear-wall and -frame system

This framing typology is essentially a combination of the two systems already outlined. The combined lateral stiffness of rigid or semi-rigid frames and core shear walls allows designers to reach heights of around 160 m cost-effectively.

This structural system is a common framing system for many tall buildings. However, with the tight floor-to-floor heights often required in modern residential construction and where flat plate slabs are used, it may be difficult to generate enough frame action to provide a significant contribution to stability. The use of beam-and slab-floor framing could potentially generate an economical level of frame action.

An advantage of the combined system, besides the ability to build taller, lies in the reduction of lateral drift at the tip of the building. At the top of the building the shear-core walls are restrained by the frames while, lower down the building, the frames are restrained by the shear walls. This interaction will typically induce a reverse-curve drift profile, so that the overall lateral deformations are maintained within acceptable design limits, and will achieve greater lateral force-resisting capacity. Refer to Figure 3.5, which shows the effect of this type of combined system on the deflection profile near the top of the building.

Figure 3.4
Type 3 - Shear-wall and frame-system.

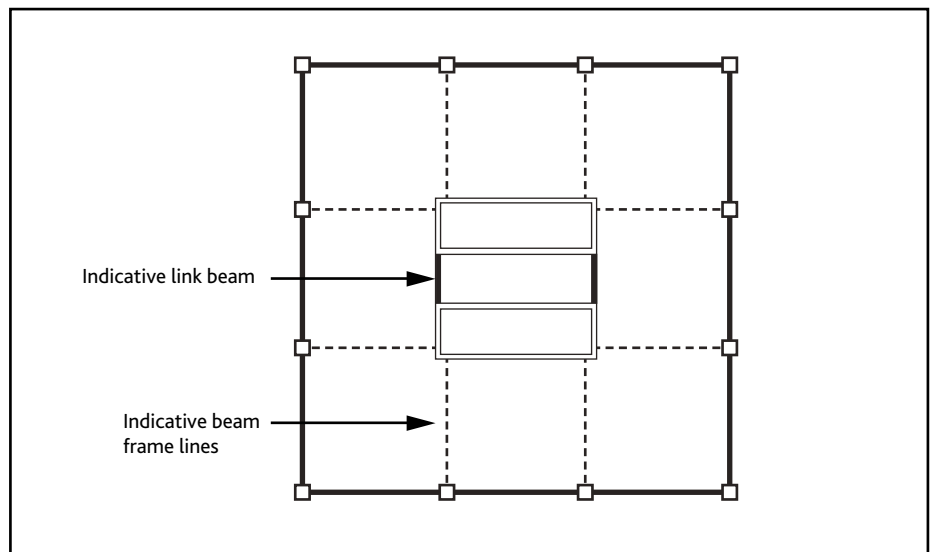

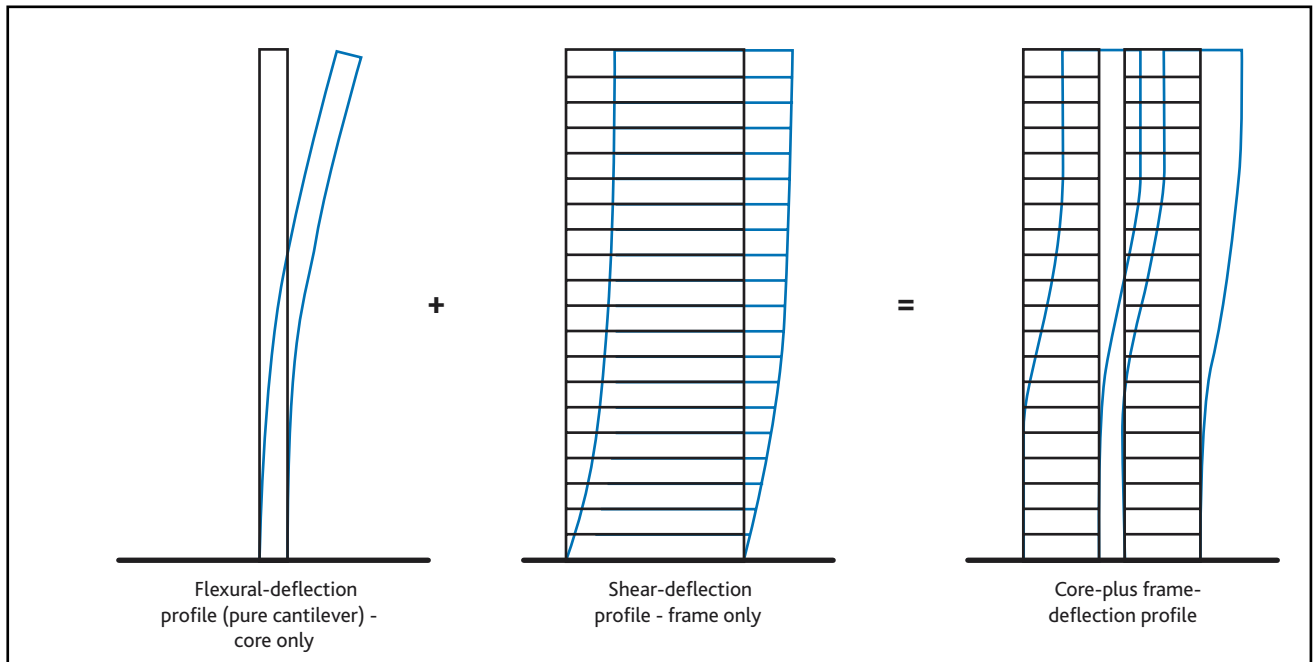
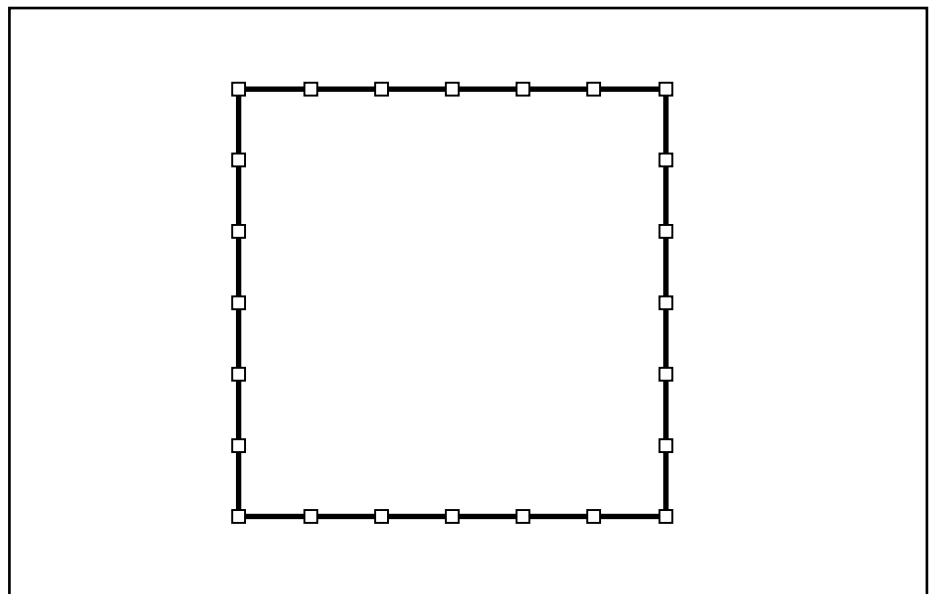

Figure 3.5
Pure bending and shear deflection profiles.

Type 4 – Framed-tube system

Conceptually, this system is based on a hollow tube, with the large distance between the tension and compression elements in both directions serving to resist lateral forces. The structural principle is based on the flange of the tube frame being perpendicular to lateral wind forces, tied at each end by the webs of the framed tube which are oriented parallel to the wind.

Figure 3.6
Type 4 - Framed-tube system.



3 Structural framing systems

In order to form an adequately stiff hollow tube, studies must be undertaken to determine the appropriate size and spacing of the perimeter members. Typically, columns should be placed at relatively close centres of 2-4 m, connected by beams to create rigid frames around the perimeter. The resulting form is a closed tube acting as a hollow vertical cantilever, with internal elements positioned as necessary to adequately support the gravity loads from the floor framing. The tube system is characterised by significant stiffness in both the major and minor bending directions, resisting the entire overturning moment on the frame.

The invention of the tube system was a major advance in tall building technology. Repetition of the structural pattern allows for simple and relatively fast construction, further enhanced by the arrangement of internal slab elements. However, this system will have a strong impact on the architectural aesthetic and may, at the outset, be deemed inappropriate.

When Khan created the framed-tube system, he demonstrated that reinforced concrete as more economical than a similarly tall steel structure; although economic conditions and material costs at any given time may have an impact on this equation.

The framed tube system is suitable for buildings up to approximately 150-170 m in height.

Type 5 – Tube-in-tube system

This system combines the stiffness of the perimeter-framed tube (Type 4) with a set of stiff internal reinforced concrete core walls. Structurally, this arrangement will act in a similar manner to the shear-wall and-frame system but will be considerably more robust due to the strong lateral strength of the outer tube.

Figure 3.7
Type 5 - Tube-in-tube system.

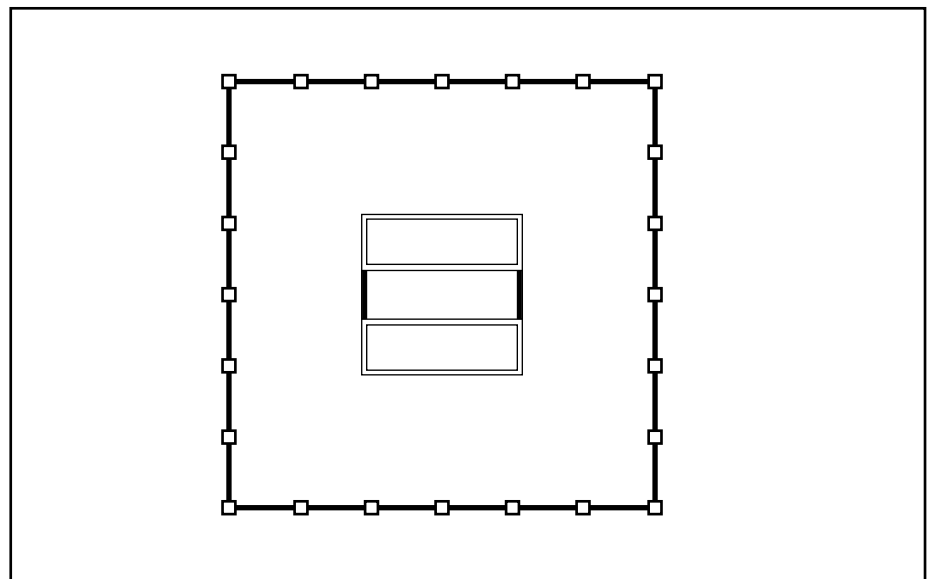

The final arrangement of the internal core and external frame, and the degree to which these two framing systems are combined, will govern the overall bending, torsional and shear capacity of the structure. A high degree of analysis, planning and coordination will be necessary to achieve the most economical balance for a particular building and, as highlighted in Type 4, this system will largely dictate the appearance of the building.

The application of this system allows for the design of buildings up to approximately 180-200 m in height.

Types 6-8 are best suited to super-tall buildings and are outside the scope of this guide but included here to provide a holistic view of available options.

Type 6 - Bundled-tube system or modular-tube system

This system is best suited to building heights greater than 70 storeys, or super-tall structures. While this system performs in the same manner as the tube system, the number of 'flange' frames is increased by introducing inner 'web' wall or frame elements splitting the plan area into a series of modules. The term 'bundled' describes the adjacent nature of the modules, all of which should be apportioned to share lateral loads across the width of the building in both directions.

The principal benefit of this system lies in the robust linkage of relatively smaller flange sections by numerous web elements. This decreases the effect of shear lag within the effective flange sections, thereby using the strength capacity of the flange frames more efficiently. This system also typically allows for greater space between the outer columns, inadvertently benefitting the architectural arrangement.

Khan called this system a 'rigid tube' and a 'true cantilever', and the significantly increased stiffness will allow the efficient design of 225 m-tall buildings.

Figure 3.8
Type 6 – Bundled - tube system or modular-tube system.

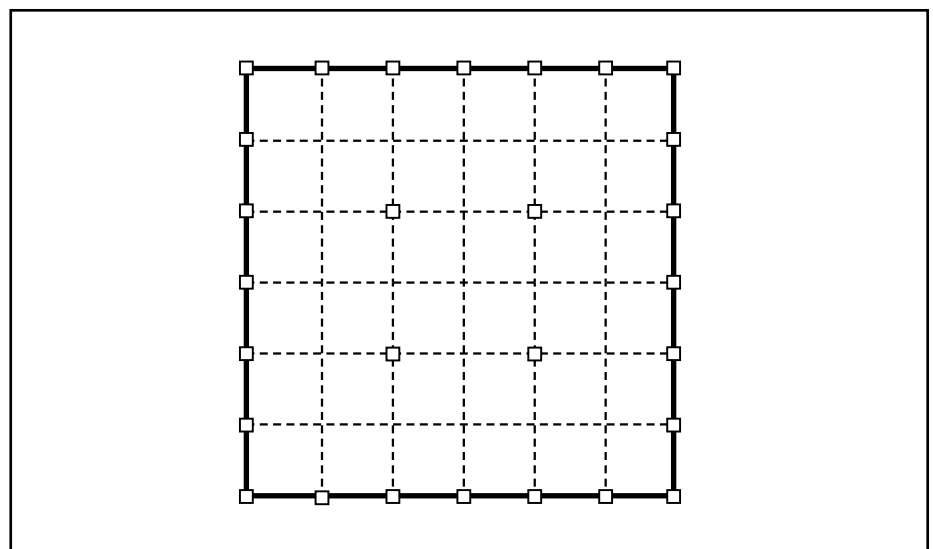

3 Structural framing systems

Type 7 - Braced-tube system

Similarly to the bundled tube, this system uses diagonal bracing added to the perimeter tube frames to increase the tube system's lateral stiffness and accommodate increased building height. This allows for greater column space and thus more free area for glazing within the façade. With this structure, the aesthetic form of the building is largely dictated by the diagonal bracing lines.

The external tube elements act as bracing frames by transferring lateral loads to the foundations along the diagonal tension and compression lines, and also redistribute the gravity loads from the highly stressed to less stressed columns, ensuring a high degree of structural redundancy and many load paths.

This system is most suited to buildings up to 300 m, or super-tall.

Figure 3.9
Type 7 - Bracing-tube system.

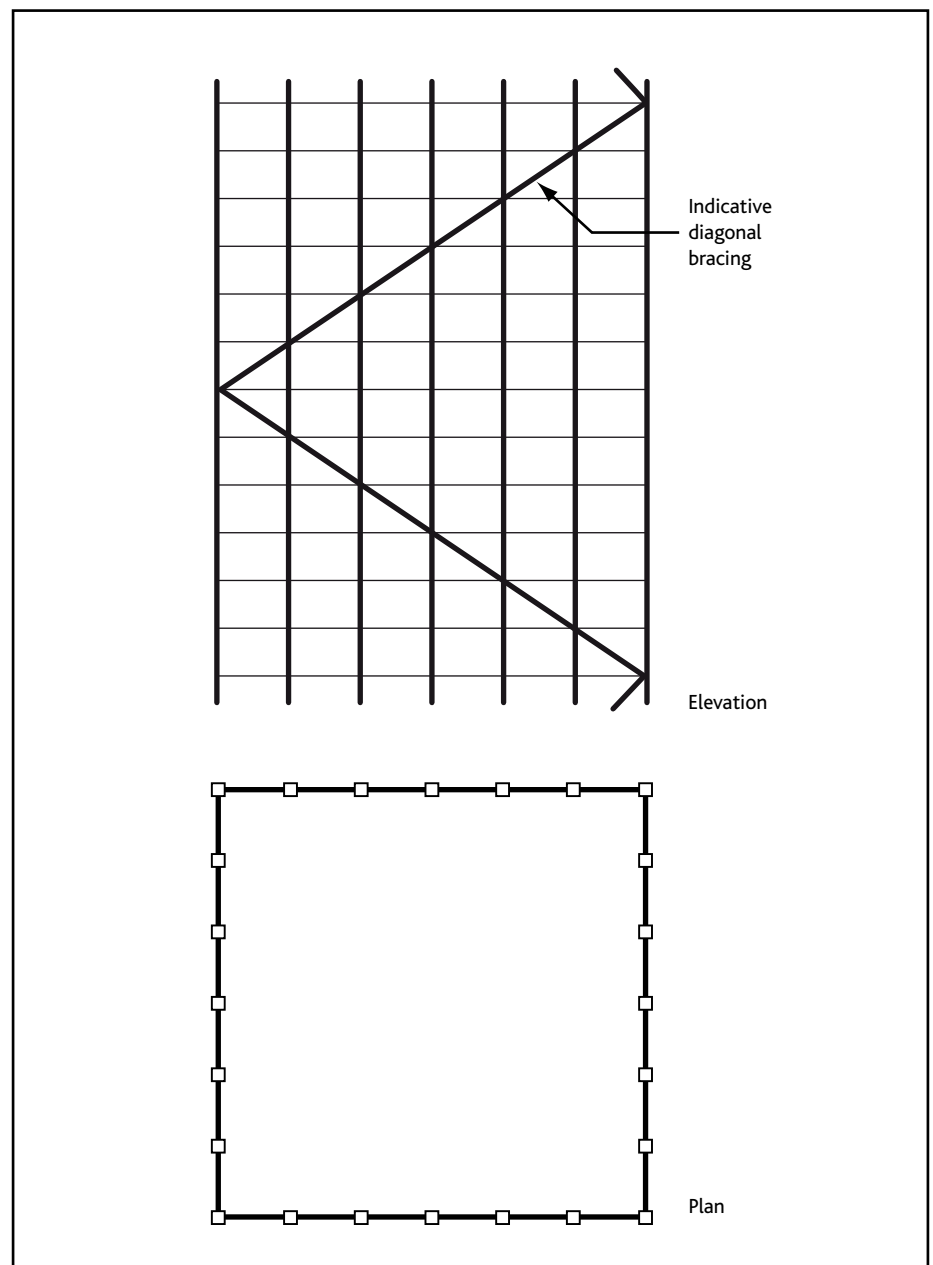

Type 8 - Outrigger-braced system

This system is used for the design of structures up to 350 m tall, or super-tall. The concept of using outriggers can be applied to much shorter buildings.

Attaining the necessary increase in overall lateral stability of the structure requires perimeter columns as a fundamental part of the structural system. This can be done through the introduction of horizontal outrigger elements (often trusses) of one or two floors deep, connecting the core with the outer columns at regular height intervals up the building. At the same level as the outriggers will be exterior solid walls or trusses – often termed 'belt trusses' – up to two storeys deep, connecting the perimeter columns to the outriggers and also serving to distribute vertical loads.

This type of system activates a series of 'push-pull' couples in the perimeter columns, redistributing stresses due to vertical bending in the core and consequently reducing uplift at its base. Horizontal deflections at the top of tall buildings are reduced, compared to similar systems, since the core is restrained by the perimeter tube.

Figure 3.10
Type 8 – Outrigger - braced system.

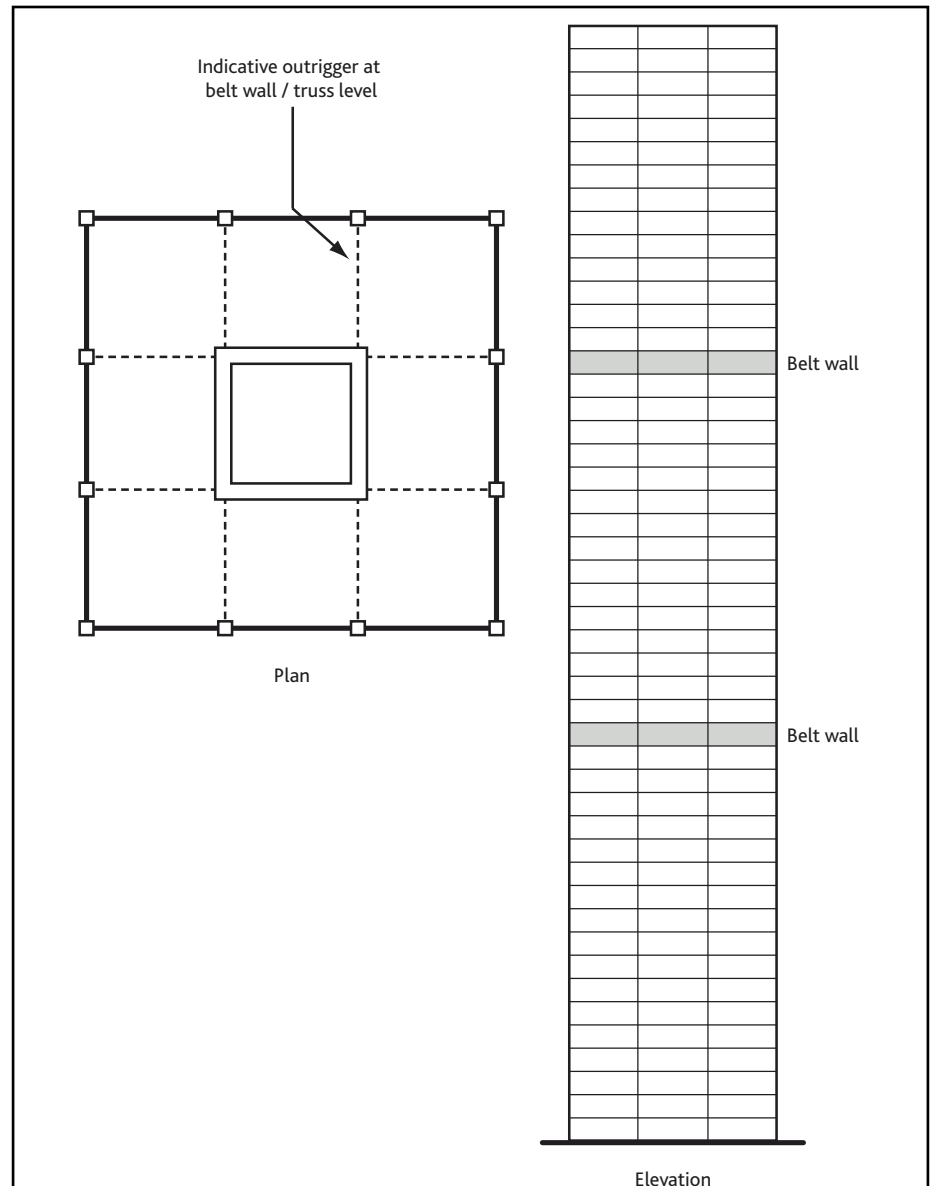

3 Structural framing systems

The substantial lateral stiffness of this system is provided mainly by the central 'mega-core' governing the overall structural bending, shear and torsional stiffness of the structure. The large size of this core does not usually preclude the use of this system; it is, in fact, a natural requirement given the structure's height as well as the great number of occupants and lifts that this system must accommodate.

4. Structural elements

Tall buildings are made up of the typical elements used in low-rise construction, namely, walls, columns and floors/beams. Their use in tall buildings can, however, impose additional demands on their performance and this needs to be considered and addressed by the engineer during the design, detailing and construction stages.

When embarking on the design of tall structures an engineer now commonly use 3D computer software, which adopts finite element modelling (FEM) techniques. Many software packages offer a high degree of sophistication in modelling structural behaviour, allowing the engineer to gain a very good understanding of how the structure will behave when subjected to various load cases. However, care and experience is required when using such software to ensure that the various structural elements are modelled appropriately.

To ensure the quality and reliability of the structural analysis carried out with FEM software (that often have hundreds of thousands of nodes) elementary precautions should be taken including:

- Checking the following key results with a straightforward approach based on simple calculations and traditional approaches:
 - Global vertical loading and vertical loading of the main load-bearing elements (columns, walls).
 - Horizontal displacement at the top of the building under the effect of horizontal actions.
 - Vibration period and assessment of the maximal acceleration at the top of the building.
- Building a FEM which not only reflects the structure's geometry (overall dimensions, foundation thickness, slab thickness, column dimensions, etc.), but which also best represents the mechanical properties and long-term behaviour of the reinforced concrete.
- Appropriately modelling the ground/structure integration. This typically requires the formulation of a separate FE model of the ground and an iterative process to align the behaviour of the structure and ground models. See Chapter 5.

It is also important that the engineer considers the likely construction sequence during the formulation of the structural FE model and in the design of the structural elements. The construction sequence and methodology can impose additional load cases and design considerations, for example, where the core walls are progressed ahead of the surrounding floors and columns.

4.1 Floors

The primary purpose of floors is to support the applied floor loadings and distribute the loading to the supporting walls and columns. Depending on the structural framing system adopted, the floor structure may also contribute to the lateral-load-carrying system, either via diaphragm action or in more complex ways. For certain stability systems, the floors may contribute directly and form the horizontal elements of moment-resisting stability frames. In some cases, integral beams are added to the floor construction to provide increased stiffness and load capacity. When the floor does contribute in some way to the lateral load carrying system, load reversal may be possible and strength assessments should be used to ensure all load cases are addressed.

4.1.1 Performance requirements

Floors are subject to bending, shear and axial loading, and require adequate strength and stiffness to resist the applied loading whilst remaining within the specified deflection and vibration limits. While all of the flooring systems used for low-rise construction can be adopted for tall buildings, a number of factors narrow down the choice. The primary considerations are discussed in this section.

Floor depth

As the floors within tall concrete buildings repeat many times, even a small saving on floor depth can become significant. For example, a saving of even 100 mm per floor would result in a 4 m saving over the height of a 40-floor building, allowing an extra floor to be accommodated within the same original envelope and producing valuable additional revenue. Alternatively, a 4 m height of cladding could be saved, which over the full perimeter of the building could produce significant cost savings.

Overall weight

Any weight saving is multiplied across repeating storeys, thus any saving can have a significant effect on the sizing of vertical elements and the foundations. Weight and material savings can also speed up the construction through reduced crane requirements.

Speed of construction

Speed of construction plays a vital role in the viability of a tall building. The time taken to achieve a return on the investment is crucial to funding arrangements; construction cost is influenced greatly by construction period. The floor construction will, in turn, influence the contractor's ability to construct the building quickly. In comparing flooring systems, one of the key criteria should be the cycle time from floor to floor. For most tall buildings, the contractor will aim to achieve a cycle time of somewhere between four and seven days. This is a very short period and it should be noted that this period includes the time needed to construct the supporting columns and walls at each level. The floor design needs to facilitate such rapid construction demands and the designer will need to consider factors such as concrete strength gain, back-propping requirements and reinforcement fixing details. The ability to prefabricate reinforcement cages, for example, can offer an advantage.

Additionally, normal serviceability criteria will need to be considered during the design process, including cracking, deflection, acoustic performance and vibration response. Careful consideration must be given to construction tolerances and floor deflections, particularly at the slab perimeter, where cladding systems are attached.

Axial shortening effects

For tall buildings, the effects of differential axial shortening must be considered in floor design. Differential axial shortening can occur in all buildings but becomes more noticeable as building height increases. Differential axial shortening arises due to the different levels of axial stress in the columns of the building compared to the core.

Core walls are generally quite large, with their size influenced by both axial stress requirements and stiffness requirements to resist lateral loads. Columns, by contrast, are usually kept as small as possible and are generally more heavily stressed. As construction progresses, columns and core walls undergo elastic and creep shortening at differing rates. The effect on the floor slab is like having a spring support at some of the support locations altering the distribution of moments and shear forces around the floor plate, requiring reinforcement rates to be adjusted accordingly in floor design. The differential relative settlement of supports can also affect the levelness of floors and, if not carefully considered and compensated for in design and construction, may give rise to tolerance issues for floor finishes and cladding details.

Axial shortening effects are discussed further in Chapter 11.

Modelling Floors

When modelling floor elements within an FE model, consideration should be given to the following points:

- The node spacing within the FEM mesh must neither be too close nor too tight, particularly in zones where constraints are concentrated e.g. close to supports. Advice should be sought from the FEM software provider as necessary.
- Reinforced concrete floors can rarely be fully fixed into the core due to practical considerations, for example, limitations on the diameter/spacing of passive-reinforcement steel projecting from the core. The floor/wall connection should therefore be modelled appropriately so that the stiffness of the wall/floor joint is not over-estimated.
- Cracking will occur in the floor elements, which will affect the stiffness of the floor. Again the material properties used in the FEM model should be set accordingly.
- Where floors include beam elements the model must accommodate the eccentricity of the beam and floor centre line. Such effects can induce bending within the floors and beams, particularly where the horizontal elements also transfer significant in-plane forces.

4.1.2 Flooring systems

For all of the above options, either reinforced concrete or post-tensioned concrete can be adopted. Post-tensioning of the flooring elements is a popular choice for tall buildings due to the improvements it brings in reduced overall thickness and weight, while speeding up construction. Where post-tensioning is proposed, it is important to consider the following points:

- Restraint to the pre-stress shortening due to stiff-core walls and columns
- Access to undertake the stressing often required from the building perimeter
- Method of providing a tie into the core walls when progressed ahead of the floors







Post-tensioning will generally only be designed to resist gravity loadings and traditional reinforcement may be required to cater for any load reversals caused by lateral loading from wind or seismic events.

The use of precast concrete floors systems can offer some advantages in terms of speed of construction and can also offer large-span floors, which are attractive for office and retail uses. Precast solutions also have benefits relating to concrete supply at high level, back propping and strength gain. Where precast floors are used it is essential that the engineer fully considers the robustness of the structure and provides the requisite ties between the individual precast elements to ensure that the structure as a whole can perform adequately in the event of accidental loading.

Precast systems require more craneage to construct the building. If a precast flooring system is proposed it is essential that the craneage and lifting strategy to be used for the construction is well considered ideally in conjunction with the constructor.

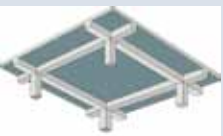
A summary of the typical flooring solutions is provided in Table 4.1.

Table 4.1
Floor solutions.

Slab type	Floor depth	Overall weight	Speed of construction	Overall rating	Comments
 Flat slab	✓✓✓	✓✓	✓✓✓	✓✓✓	Easy to form and quick to construct. Offers a thin floor plate, which is good for coordination with building services.
 Flat slab with drops	✓✓	✓✓✓	✓✓	✓✓	Structurally efficient but slower to form and construct. Overall depth can be efficient if building services and dropped panels can be coordinated.
 Solid two-way slab with beams	✓✓	✓✓✓	✓✓	✓✓	Structurally efficient but slower to form and construct. Beams can be useful where flooring system is used to contribute to lateral stability system.
 Waffle slab	✓	✓✓✓	✓	✓	Structurally efficient in terms of material weight but considerably slower to form and construct. Also produces a large overall depth and hence is rarely economic for tall buildings.
 Solid one slab with beams	✓✓	✓✓	✓✓	✓✓	Structurally efficient but can be slower to form and construct. Beams can be useful where flooring system is utilised to contribute to lateral stability system in the direction of the beams. Overall depth can be efficient if building services and beams can be coordinated. This arrangement is suitable for use with precast components
 Solid flat slab with band beams	✓✓	✓✓	✓✓	✓✓	Structurally efficient but can be slower to form and construct. Beams can be useful where flooring system is used to contribute to lateral stability system in the direction of the beams.
 Ribbed slab with beams	✓	✓✓✓	✓	✓	Structurally efficient in terms of material weight but slow to form and construct. Also produces a large overall depth and hence is rarely economic for tall buildings.

Key to ratings:- ✓ - Poor ✓✓ - Good ✓✓✓ - Excellent

4.2 Columns

The primary purpose of columns is to support the floors and distribute vertical loading to the ground. Columns are generally spaced at regular intervals along the perimeter of the structure but, for larger floor plates, interior columns are frequently needed to reduce the span of the floors.

The design of the core benefits from supporting a larger share of the vertical loading, as this assists with resisting overturning from lateral loads. Spacing of columns from the core should, therefore, ideally be maximised. The central core may typically support about 60 % of the vertical loading, with the columns supporting the remaining 40 %.

Columns may be arranged to form part of the stability system, as discussed in Section 4.2.1, and this will make further demands on the performance of the columns.

4.2.1 Performance requirements

Columns are mainly subjected to axial compression. When selecting the column arrangement, engineers should consider the following factors:

- Reducing column's geometric footprint to increase façade transparency and create more floor area
- Ease of detailing and connection to floors' structural system
- Speed of construction
- Robustness of the element and its resistance to fire
- Minimum of intrusion into the building's façade.

Concrete is well suited to economically resist high levels of compression stress and can be pumped at high altitudes (614 m from the ground for the Burj Khalifa in Dubai).

High-strength concretes can be used if the type of construction allows it; the gain in usable floor area, resulting from the reduced column cross section, can compensate for any additional cost.

Modelling columns

When modelling column elements within an FE model, consideration should be given to the following points:

- When a column changes dimensions between two successive levels, the model should take into account the corresponding offsets in the column centre lines or it may neglect the associated bending moment induced within the column. This situation is common in façade columns, whose dimensions reduce towards the top of a structure and where the façade face is continuous.
- Where 'walking columns' are used, the offset of the columns can be significant and will induce significant lateral forces with the floor elements.

4.2.2 Column spacing

The spacing of columns within the footprint of the building is determined in collaboration with clients and architects. Columns will be positioned to facilitate ease of layout for the appropriate use of the floor spaces. Due to the size of the columns in tall buildings, it is not normally possible to conceal them within walls, as is common practice in low-rise construction. Adjustment of column layout should be kept to a minimum, as each change in plan position requires some form of transfer structure, which can be expensive, slow the construction rate and occupy more depth than a typical floor plate.

Column spacing is generally kept in the range of 6-10m, as this produces economical column sizes and floor depths whilst maintaining usable floor plates. Wider spacing is generally more suitable for office use, with smaller spacing acceptable for residential purposes. Should the building use change through the height of the building, a single transfer floor may be appropriate and can generally be assigned for plant and equipment or as part of the building's stability system.

A small adjustment in column locations, floor-on-floor, can be achieved by using 'walking columns' stepping the column positions incrementally over a number of floors to achieve the overall desired offset. See Figure 4.1.

The eccentricity of the vertical loading at each floor is resisted by tension and compression forces within the floor structures. Floors, therefore, become part of the vertical load carrying system and, in addition to gravity loadings, must be designed and reinforced to resist additional lateral loadings and treated appropriately in terms of their response to accidental loadings, robustness and disproportionate collapse.

Column spacing at the perimeter of the building can be influenced by the selected façade. In modern buildings an open façade is often provided and columns centres are maximised for the least intrusion into the façade line and views for the building occupants.

Figure 4.1
'Walking columns'.

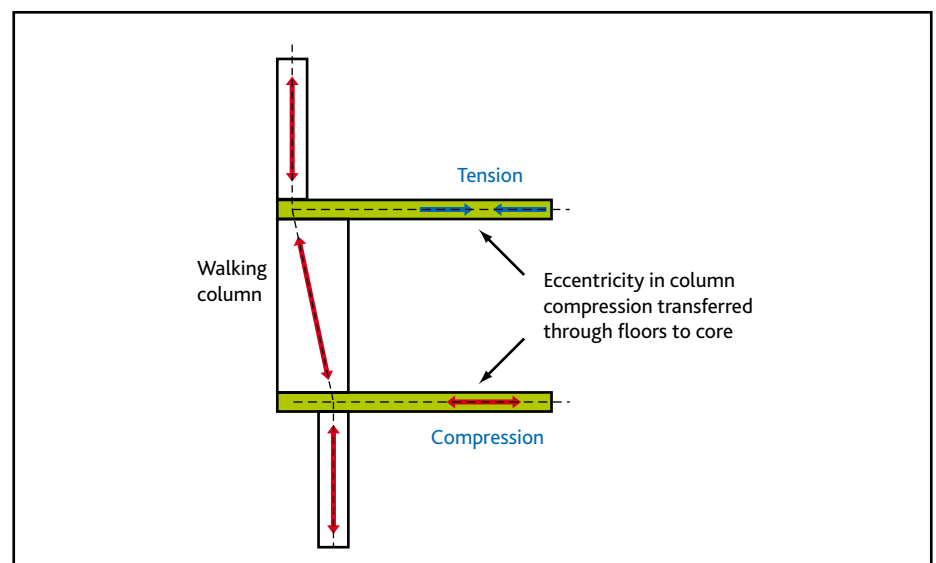

Often, a short cantilever slab is provided at the building perimeter, allowing the façade to run past the outer columns in an uninterrupted line. This can simplify and regularise the details for the façade and help with the detailing of the column/floor slab connection.

If the outer columns of the building are utilised as part of the lateral load carrying system - for example, in a framed-tube structure - column spacing will be much smaller (perhaps 2-4m) and the slab edge will be formed with the stiff interconnecting beams.

4.2.3 Column sizes

The initial sizing of columns will take into account the following factors:





- Axial and bending stresses
- Slenderness, particularly for very tall columns (entrance areas, double height spaces)
- Fire resistance and, hence, cover requirements, particularly for columns using high-performance concrete - guidance is provided in most national codes
- Structure robustness criteria.

When sizing the columns in tall buildings, the designer should also consider the following factors:

- Obtaining uniform stress levels across the columns and walls in a single floor plate in order to reduce differential shortening effects.
- Being mindful of changing concrete strength too abruptly - for example, a floor made of C40 concrete located between two columns using C80 concrete may cause problems.
- Being aware of differential temperature effects on façade columns exposed to direct sunlight.

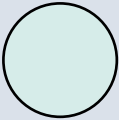
Common column shapes are compared in Table 4.2.

Table 4.2
Comparison of common column shapes

Column shape	Technical feasibility	Economy	Ease Of planning	Overall rating	Comments
 Circular	✓✓	✓✓	✓✓✓	✓✓	A regular and compact shape, convenient to accommodate. Forming shape can be more expensive.
 Square	✓✓✓	✓✓✓	✓✓✓	✓✓✓	The most relevant shape to resist bending effects; also the easiest one to construct. A regular and compact shape which is very convenient to accommodate.
 Rectangle b:h < 3:1	✓✓	✓✓✓	✓✓✓	✓✓	Strength influenced by slenderness for smaller side dimension. A regular and compact shape which is convenient to accommodate.
 Rectangular b:h > 3:1	✓	✓✓✓	✓✓	✓✓	Strength influenced by slenderness for smaller side dimension. Likely to attract lateral loading and hence may need to be considered as a shear wall. Can be convenient in structures where cross walls suit the intended use.
Key to ratings:- ✓ - Poor ✓✓ - Good ✓✓✓ - Excellent					

4.2.4 Vertical loading and horizontal forces

The compression stresses applied to columns can quickly be determined by carrying out a floor-by-floor 'manual' vertical load take down, assigning the floor area supported by each column. Increases should be added for the continuity of floor structures. Manual load distribution techniques can also approximate the stresses generated from lateral loadings.

Another vertical-load take-down comes from the analysis model for the entire building. It is good practice to use both manual and computer techniques, as this provides a good insight into the load paths through the structure and also acts as a good method of verifying that the analysis results are correct.

Loading conditions during construction

An analysis of the full building will only look at the completed structure as a whole and may not fully take into account loading conditions during the construction process, which may produce more onerous load cases. For example, in the absence of higher axial loadings in the final condition, higher bending stresses in columns may require additional reinforcement. Good practice involves undertaking a consideration of column design at key construction stages to investigate such effects.

Changing column size

When selecting column sizes, axial loading can reduce significantly over the height of the structure. While corresponding changes in the column cross-section can be appropriate, consideration should be given to construction and design impacts, as frequent changes can be costly in terms of formwork and speed of construction. Changes in cross-section should be limited and, ideally, only undertaken at a minimum of every five floors.

Changes in column size can also produce localised additional bending forces in the structure, if the column centre lines are not aligned. Architectural design often requires one face of a column to remain in line at such changes in size, changing the centre line of the column cross-section and, thus, the line of action of the vertical load. Such steps in the column lines can usually be accommodated through appropriate design and detailing of the reinforcement at these locations.

Using high-strength concrete in columns

The use of high-strength concrete, particularly for columns, is not unusual and strengths up to 80 N/mm² are often used. High-strength concrete (up to 120 N/mm²) has been used on some tall buildings although this is less common. High-strength concrete can perform differently in a fire situation and, hence, where high-strength concrete is specified, the fire resistance should be thoroughly researched and verified.

Where high-strength concrete is selected for use in the columns, care should be taken with the design and specification of floor slabs between the columns. For example, if C80 concrete is specified for the columns and C40 for the floor slabs, a design check will be required to confirm the column loadings can be adequately transmitted through the lower-strength slab zone. Most national standards provide guidance for this situation and may require the provision of additional containment reinforcement through the slab or set a limit on the differential concrete strengths between column and slab. A higher concrete grade can be specified in the slab zone in the immediate vicinity of the column,

although this is difficult to achieve in practice and is not recommended unless rigorous procedures are put in place at site level to ensure compliance.

4.2.5 Composite columns

For heavily-loaded columns, a potential consideration is the use of composite columns. Composite columns combine the use of large, rolled fabricated-steel sections encased in concrete and can provide increased axial load capacity at a reduced cross-sectional area. A number of possible configurations exist, as illustrated in Figure 4.2.

Figure 4.2
Comparison of composite column configurations.

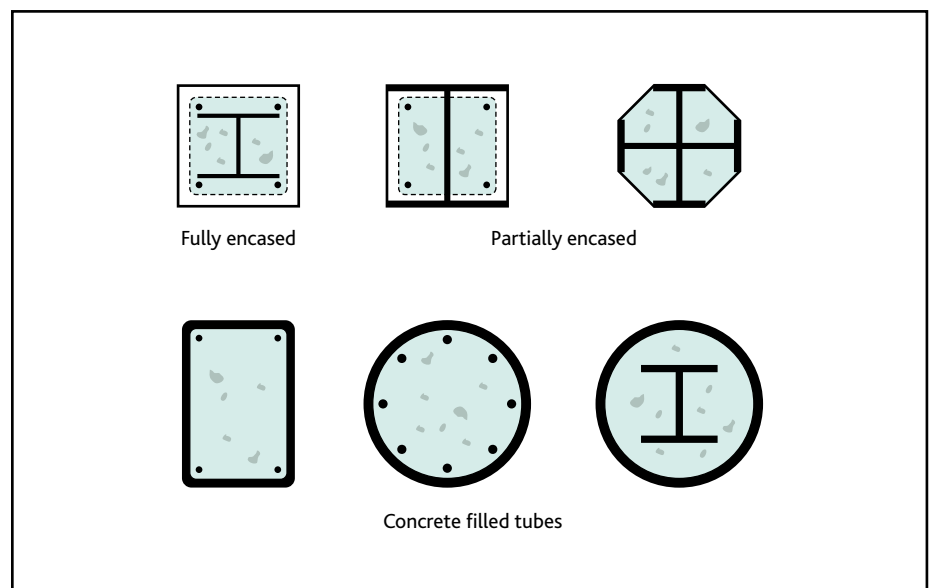

As using composite columns can greatly increase the unit cost of columns and slow down construction, they are generally only adopted if standard reinforced columns are uneconomical due to size constraints.

Design guidance is available in some national codes, including Eurocode 4: *Design of composite steel and concrete structures*. Further design guidance is available in the following publications:

- Composite Column Design to EC4 (SCI, 1994)
- Designers' Guide to EN 1994-1-1 (Johnson and Anderson, 2004)

4.3 Walls

When structural walls are provided within tall buildings, they frequently have two primary functions. The inherent in-plane stiffness of the walls will normally contribute to the lateral load carrying system in the building. They also support vertical loadings and, wherever possible, the vertical loading in a wall should be maximised to counter lateral loadings by helping to resist associated over-turning.

As noted in previous sections, the core walls of tall buildings may resist most, if not all, of the lateral loadings and typically may support around 60 % of the total vertical loading on the building.

The individual walls making up a core are often connected by link beams. Such beams are often used to connect discrete walls and, thus, increase the overall stiffness of the core. Link beams can attract significant forces and must be sized, designed and detailed accordingly.

4.3.1 Performance requirements

Walls are mainly subjected to in-plane shear forces and axial compression. When selecting the wall arrangement, engineers should consider the following factors:

- Reducing walls' geometric footprint to maximise usable floor area
- Ease of detailing and connection to floor structure
- Speed of construction, particularly ease with which walls can be slip- or jump-formed
- Robustness of walls and their resistance to fire.

Concrete is well suited for use in the walls of tall buildings, as it can most easily accommodate in-plane shear forces and associated compression. As wall sizes are most often established from requirements for stiffness rather than strength, high-strength concrete is not commonly used in the construction of walls, except for the tallest of structures.

Modelling walls and linking beams

When modelling wall elements and any connecting link beams within an FE model, consideration should be given to the following points:

- When a wall changes dimensions between two successive levels, the model should take into account the corresponding offsets in the wall centre lines or it may neglect the associated bending moment induced within the wall. This situation sometimes occurs in core walls, where the wall thickness reduces towards the top of a structure and where inside face is continuous.
- Where link beams are provided to connect between the walls of the core, the correct representation of the reinforced concrete rigidity of these beams is fundamental to the global rigidity of the core.
- The properties of the link beams must take into account their degree of cracking. The beams are generally relatively deep in comparison to their span and hence are dominated by shear deformation rather than bending. This can lead to an increased degree of cracking with the beam section. The rigidity (EI) of the link beam is normally adjusted (reduced) to take account of this increased degree of cracking.

- In the FEM software the link beams are often represented by beam elements connecting between the wall elements of the core. It is good practice to increase the length of the FE elements by one or two FE mesh nodes at each end to more accurately represent the attachment of the beams into the core walls.

4.3.2 Wall positioning

While the spacing of walls within building footprints will be determined in collaboration with clients and architects, structural engineers have a key role to play with positioning of the main lateral load carrying walls critical to the performance of the building.

Ideally, walls should be placed symmetrically around the global centroid of the building in each principal horizontal axis, to reduce the torsional response of the building to lateral loadings. Positioning walls to intersect at right angles can greatly increase the stiffness and stability of the walls overall, allowing them to work compositely to resist lateral loading.

Frequently, the main walls in a tall building are positioned around the central core where the lift shaft and staircases serving the building are housed. A convenient location for the structural walls, it provides a very efficient structural form and is often the first pass layout for the walls; from which a final layout can be developed following an iterative process.

4.3.3 Wall sizes

The initial sizing of the walls will take into account the following factors:

- Axial and bending stresses
- Overall stiffness to resist lateral forces and limit lateral deflections
- Buckling resistance, particularly for very tall walls (entrance areas, double height spaces etc.)
- Fire resistance and hence cover requirements - guidance is provided in most national codes
- Structure robustness criteria.

In addition, wall sizing decisions must take into account the following factors more specific to tall buildings:

- Standardisation of shape and cross-sectional area to aid with speed of construction and buildability.
- Obtaining uniform stress levels across the walls and columns in a single floor plate to reduce differential shortening effects.
- Minimising offsets in wall position, particularly in the lower part of very high towers, as the resultant horizontal component can be difficult to accommodate.

In establishing the cross-sectional dimensions of walls, the length of wall available is normally set by architectural layout and, for example, number of lifts. Providing this length is reasonable to accommodate the required overall stiffness, engineers can fine tune stiffness and strength requirements by adjusting wall thickness. Wall thicknesses ranging from 350-800mm are not uncommon in tall buildings.

4.3.4 Vertical loading and horizontal forces

As for columns, compression stresses applied to walls can quickly be determined by carrying out a floor-by-floor 'manual' vertical load takedown, and assigning the floor area supported by each wall. It is vital for the continuity of floor structures to be taken into account, as the large stiffness provided by walls can greatly increase the effective areas supported.

Manual load distribution techniques can also approximate stresses generated from lateral loadings using simple hand methods of calculating and attributing the relative wall stiffnesses. The results from hand analysis can be compared to a full computational analysis model for the entire building for verification.

Loading conditions during construction

Again, as for columns, it should be remembered that the analysis of the full building will only look at the completed structure as a whole and may therefore miss loading conditions during the construction process. Temporary conditions may produce more onerous load cases, particularly if core walls are advanced ahead of the remainder of the structure with techniques such as slip- or jump-forming. Core walls can, in some cases, be advanced 10 or more floors ahead, with the result they are exposed to very different loading and restraint conditions than in the final design. Studies should be undertaken to consider the behaviour and strength of walls during construction.

Changes in wall thickness

Axial loading in the walls will reduce significantly over the height of the structure. Although wall thicknesses are sometimes reduced at increasing height up buildings, constructional difficulties can arise and the impact of walls' overall stiffness must be factored into the design.

Changes in the thickness of walls will produce out-of-plane bending moments if the wall centre lines are not aligned. Architectural design often requires one face of the wall to remain in line at changes in size, changing the centreline of the wall cross-section and, thus, the line of action of the vertical load. Even small offsets in the wall centre lines can produce very large bending moments, as the vertical loads involved can be significant, although they can often be accommodated by appropriate local reinforcement detailing.

Positioning openings in walls

Openings (such as lift shaft doors) will be required through most of the walls to facilitate access for users of the building and for mechanical and electrical services. Opening positions can significantly influence the stiffness and strength of the wall. Any openings through the main walls should be positioned away from the end sections or any junctions with perpendicular walls, as these zones tend to be more heavily stressed. Openings should ideally be placed in the middle half of the plan length of the wall.

Openings repeating at each floor level, as is the case with lift doors, can leave only relatively shallow sections (or link beams) connecting two longer sections of wall. Link beams are required to transmit very large shear forces as they often act to couple two sections of wall. Modelling the behaviour of link beams requires careful consideration, as does their design and detailing, to ensure the link beams can resist the applied forces and can be constructed efficiently.

5. Foundations

Early tall building developments tended to be in areas such as Chicago and New York, where, fortunately, ground conditions were conducive to carrying high building loads. As these types of structures have spread to other parts of the world, more challenging ground conditions have been encountered.

This has inevitably resulted in the adoption of various foundation solutions to reflect the strength and compressibility of the underlying deposits. For example, while Chicago and New York are underlain by high-strength rocks – Dolomite and Metamorphic, respectively – Shanghai within the Yangtze River delta is underlain by over 100m of soft sedimentary deposits and yet has super-tall buildings (at time of publication, Shanghai World Financial Centre, at 492 m, is the tallest). London is to a large degree underlain by stiff London Clay but, generally, tall buildings such as those at Canary Wharf are supported by piles bored into the dense Thanet Sands found below the clay deposits.

A geotechnical specialist should always be consulted to advise on the foundation solution for tall buildings.

Ground conditions

When founding on deposits of high strength and low compressibility, with evident spare capacity in the ground to carry anticipated building loads, taking accurate measurement of parameters is not of paramount importance. However, failure to properly sample, test and evaluate many deposits can result in adopting inefficient and overly expensive foundation solutions.

Over recent years, considerable effort has been expended on improving laboratory and in-situ testing methods to more accurately measure parameters used in design. Historically, much design work has relied on empirical correlations as an approximate means of deriving a foundation solution but they can be generic and conservative, resulting in an over-designed and relatively expensive sub-structure.

Prevailing ground conditions and a site investigation should point towards a basic methodology for foundation design. The options range from fully piled solutions using caissons or barrettes to transfer loads away from weak deposits towards deeper and firmer strata, to a raft transferring all the building loads directly onto the strata immediately below the building footprint.

In many cases engineers opt for one of these two basic approaches. The advent of better modelling techniques, however, enables composite systems using a raft and piles in combination to be used. Composite systems can better address uncertainties in the ground and in the performance of individual elements of the foundation system. For example, if the raft has a tendency to settle to a greater degree than anticipated, the piles take a greater share of the load while, if the piles perform worse than expected, the raft carries the additional load. To an extent, the combined system is self-compensating.

Basements

The majority of tall buildings have deep basements associated with the overall development; frequently extending well beyond the footprint of the main building.

Often the permanent groundwater table is well above basement level and, therefore, significant uplift pressure can be generated. Outside of the main building footprint, the basement either has to be held down (generally by tension piles or anchors) or the entire area has to be under-drained.

To support the soil and water pressures exerted on the basement walls, lateral loads have to be carried by slabs, unless permanent ground anchors are employed. The slabs need to exhibit continuity across the full extent of the basement and building structure. Additionally, with large spans, consideration has to be given to construction methodology to ensure shrinkage and creep of the slabs does not lead to excessive displacement of the basement walls.

5.1 Ground investigation

A major element in ensuring appropriate and efficient foundation design is undertaking a thorough assessment and investigation of the ground conditions. General methods of site investigation across the world often reflect a conservative consensus and are not optimised to achieve the best design. In many countries this is balanced with the use of empirical methods informed by real building performance. However empirical evidence does have limitations:

- Observations and empirical derivations are limited to specific strata/stratigraphic sequences of deposits.
- There is inherent uncertainty in using historical evidence to design buildings that are often substantially taller and heavier than those previously built in the region.

Without an appropriate site investigation strategy, the likely consequence is a very conservative foundation solution. Engineers should consider:

- Using a desk study to appreciate the regional geology, any potentially problematic deposits and possible geo-hazards, such as cavities, buried channels and landslips.
- Conducting sufficient boreholes and trial pits to examine the variability of deposits across the site.
- Taking boreholes deep enough to examine deposits significantly loaded by the structure. A raft foundation will affect strata many tens of metres below founding level. In weak deposits, piles may have to extend up to 80-100m below ground level.
- Obtaining good recovery of all material present. Too frequently in rotary boreholes, core recovery can be only 50-60 %. While the 40-50 % lost is probably the weaker material which will in fact dominate foundation performance, these deposits have not been sampled and will not be tested.
- Using sampling methods that limit the disturbance of samples, for example, pushing rather than hammering in tubes for cohesive deposits. For cored samples, select clean sub-samples and wrap for testing as soon as the core is obtained, as a great many materials deteriorate rapidly on exposure.

- Accurately measure sample displacement in the laboratory, using gauges attached to the central portion of the sample as measurement of platen ends is highly inaccurate.
- Ensuring laboratory testing is carried out on undisturbed samples, representative of the strata encountered.
- Undertaking in-situ testing, such as measuring elastic modulus using a pressuremeter (dilatometer), to compare with and validate laboratory results.

Groundwater levels and the permeability of strata should also be considered. Groundwater levels used for design planning are often based on water levels obtained during an investigation together with one or two readings obtained from installed piezometers. However, water levels can be highly seasonal and wrongly assessed in low permeability deposits, where pore pressures can take weeks to equalise and can be affected by the development itself in the long-term.

The assessment of permeability is important in determining measures for achieving cut-off and/or dewatering during construction, and for verifying the benefits of potentially under-draining the basement slab as part of the permanent works.

5.2 Soil-structure interaction

Tall buildings must be solidly anchored in the substratum. Under the effect of horizontal forces, the structure of tall buildings is comparable to a cantilever embedded at its base; any lack of stiffness at the base can be detrimental to the performance of the structure overall. Depending on the nature of the foundation soil, tall buildings may either rest directly on the ground via a raft foundation or be embedded on deep pile-type foundations, as described in preceding sections.

Soil-structure interaction is a phenomenon which must be considered by engineers when designing the structure of tall buildings and included in detailed construction studies.

Soil-structure interaction influences the distribution of vertical loads on the ground and stresses in the structures, design of foundations, soil settlement study and the dynamic behaviour of the building under the effects of horizontal forces (wind and seismic forces).

Incorrect evaluation may lead to cracking caused by differential settlement. It may also lead to a structure failing to meet user-comfort criteria as a result of an overestimation of the stiffness of the building. Correctly taking into account this phenomenon allows for the accurate evaluation of the settlement on neighbouring structures.

When considering the vertical load in a building and its distribution on the ground via the core and the columns, a corresponding settlement trough will occur, leading to a distribution of vertical stiffness on the whole area of the vertical loads. In the same way, soil stiffness distribution will be associated with the horizontal forces.

Figure 5.1
Comparison of geotechnical and structural models.

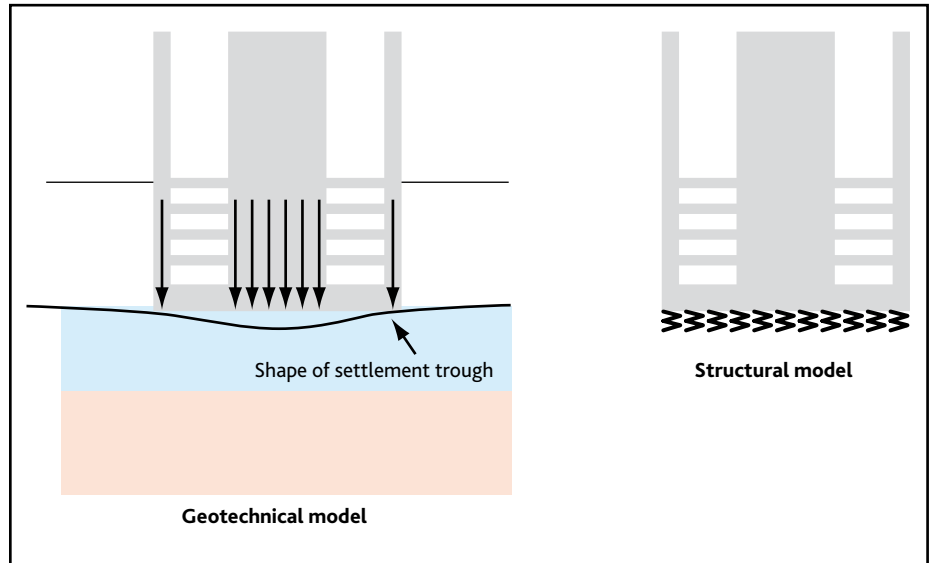

The distribution of soil springs under the structural elements in contact with the soil has a direct effect on the distribution of vertical loads.

The principle of the soil-structure interaction study, therefore, consists of a dialogue between geotechnical and structural engineers to obtain consistency between their respective calculations. A settlement trough (Figure 5.1) calculated by geotechnical engineers on the basis of vertical loads given by structure engineers must be consistent with the settlement trough resulting from the shortening of the soil springs in the structure calculation. A description of the available methods of foundation analysis is given in the following section.

5.3 Methods of foundation analysis

Foundations for tall buildings inevitably have to carry very high loads. Frequently designers prefer to adopt a deep-piled solution, which takes loads to competent strata. However, with a good understanding of anticipated soil and rock behaviour, engineers should consider a far broader range of options to derive a safe, yet economical, foundation system.

When built in solid rock, foundations could simply be a number of spread footings, used in conjunction with a raft to support the main core of the structure. On a more general basis though, designers should evaluate the use of rafts and piles, with a view to combining them.

5.3.1 Rafts

As buildings have become taller, rafts have become complex feats of engineering in their own right. Rafts can be several metres thick to accommodate the punching-shear effect of heavily loading columns, while adequate load spread should be ensured onto the underlying strata. Aspects requiring an appropriate judgement by structural engineers undertaking any form of modelling include:

- Deciding whether to treat the raft as an elastic medium; concrete is either assumed to be uncracked or cracked.
- Considering the benefits of the reinforcement, often of very substantial proportions, and its contribution to load distribution and flexure of the raft.
- Deciding on the composite stiffness of the raft and overlying structure; for example, core walls will substantially reduce the flexibility of the portion of raft underlying these elements.

When considering the interaction between the raft and the ground, structural engineers frequently analyse the problem by simplifying the entire substrata as a series of springs. This process entails identifying zones on the raft with equivalent loading. An appropriate 'spring' is derived based on the area of loading and the modulus of the underlying ground. A simplified procedure is presented in Figure 5.2.

Figure 5.2
Area spring method.

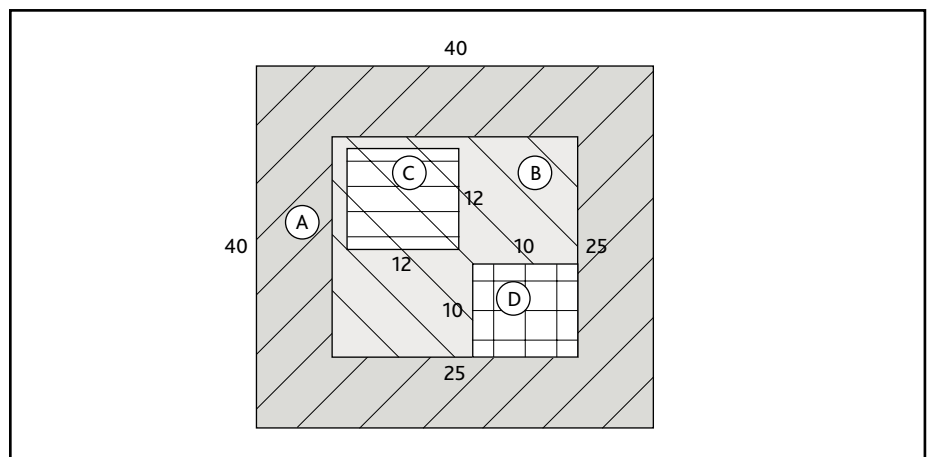

An alternative approach in the assessment of spring stiffnesses involves iteration between computer programmes, a structural programme incorporating springs and a geotechnical program evaluating settlement beneath various loading areas. An example of a 2D analysis following this procedure is given in Figures 5.3 a) and b).

Figure 5.3
2D Model Analysis.

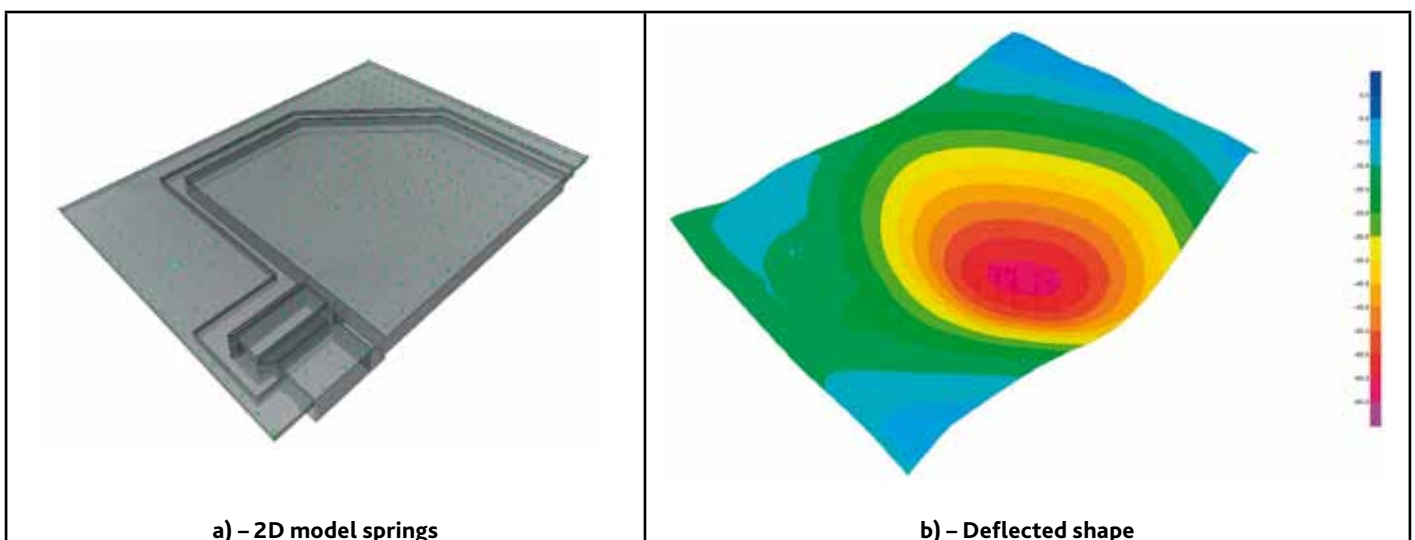

a) – 2D model springs

b) – Deflected shape

A better representation of the performance of the raft interacting with the soil can be achieved by using a 2D finite element, soil-structure interaction, software. While the raft is represented in its simplest form as an elastic element, the full sequence of soil and rock strata can be modelled beneath the raft, with the appropriate elastic moduli.

Working in two dimensions means that the adopted section can only relate to a specific load distribution which is assumed to be the same across the full extent of the raft, while the third dimension is infinite and offers columns and cores represented by continuous walls. Despite these restrictions, a good geotechnical numerical modeller can provide a reasonable evaluation of springs to be used for the structural model and a good check on the anticipated deflected shape of the raft from sagging or hogging.

An optimum solution is the adoption of a 3D finite element, soil-structure interaction, analysis model as shown in Figure 5.4. It can be used to provide details of the deflected form of the raft and the bending and shear forces induced, with the accuracy of the model only as good as the input data.

Errors in soil stiffness or load spread through the raft will inevitably give varying degrees of error in the final output. To address this, ranges of soil parameters are normally considered, to check whether variations in the deflected form of the raft are likely, and to account for this in the final detailing of the raft and its reinforcement.

Figure 5.4
3D soil structure interaction model.

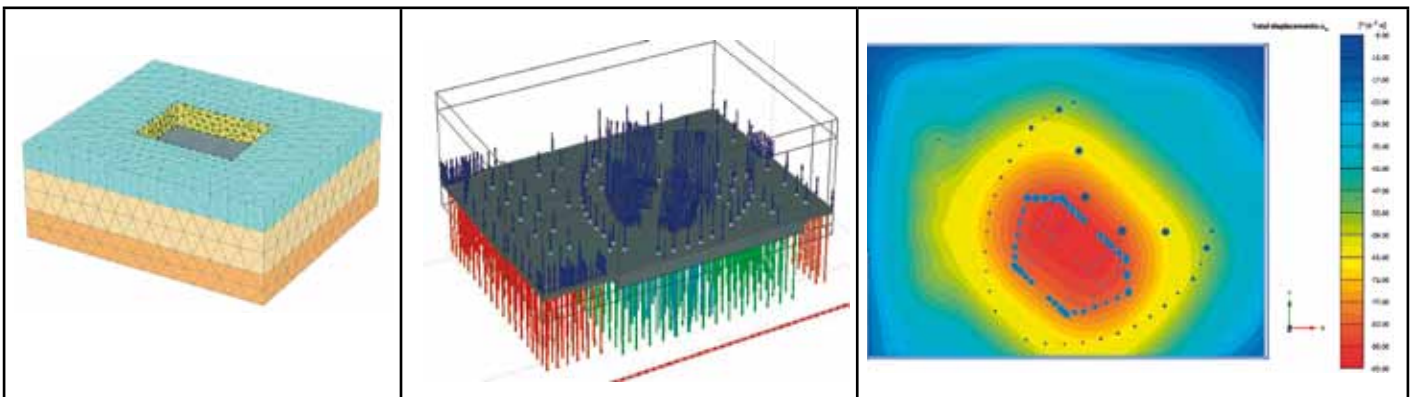

Procedure for modelling soil structure interaction

When undertaking the soil-structure interaction modelling the following procedure is recommended.

The structural model should include:

- Raft dimensions (thickness, voids, column/core locations), including the stiffness of core walls, which is significant
- Loads (point load - from column, line load - from wall, area loads - from any slabs/ plant rooms)
- A grid of spring supports with constant node spacing (generally 20 % of the average column spacing).

The geotechnical model should include:

- Ground conditions (strata, stiffness values etc) based on the site investigation data.
- The same grid and nodes as for the structural model, at the base of raft.

The soil-structure interaction should then be undertaken using the following procedure:

1. Assign a constant spring under each node in the structural model to achieve overall settlement of approximately 50mm when the model is run.
2. Import each nodal reaction from the structural model into the geotechnical model.
3. Run the geotechnical model to derive the settlement of each node.
4. For each node calculate the spring stiffness (k) using the expression;

$$k = \frac{\text{Pressure (from structural model)}}{\text{Settlement (from geotechnical model)}}$$

5. Assign this set of spring values (k) to all the nodes in the structural model to derive a new set of nodal reactions.
6. Repeat steps 2, 3 and 4 to derive a new set of spring values. This process is repeated until the nodal settlement from the structural and geotechnical model matches. This can generally be achieved in around three and five iteration cycles.

Once the settlement in both the software models converges (as established from a comparison of the settlement outputs, see Figure 5.5) the bending moment, shear, bearing pressure and deflection of the raft can be determined.

Figure 5.5
Convergence of settlement from
structural and geotechnical software.

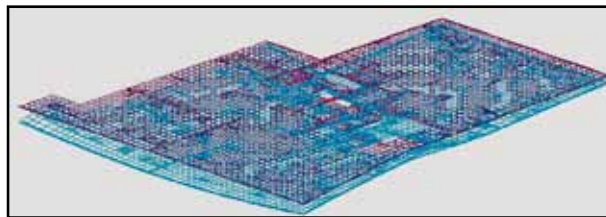

5.3.2 Piles

When a pile solution is adopted under high-rise buildings, designers usually evaluate the adoption of significant groups of large diameter piles. Although emphasis is often placed on the testing regimes of single piles to validate the overall pile design, there are distinct differences between the performance of a single pile and that of a large pile group.

The performance of a single pile is governed by two discrete facets:

- Friction generated between the pile shaft and the ground
- Strength of the soil/rock underlying the base of the pile.

For a pile group, the piles encompass a large volume of soil and the action of piles and soil working in combination will dictate group performance. As with a raft, the base of the pile group is loading a significant area of the underlying strata, and material well below the base of the piles is stressed and will thereby effect pile group settlement.

Some relatively simple procedures have evolved enabling designers to assess pile group performance, however, it is recommended that advice is sought from a geotechnical specialist.

As with raft analysis, the use of 2D finite-element, soil-structure interaction analysis requires the adoption of representative load distribution to replicate the full weight of the building. The piles themselves are represented as equivalent walls. Despite these limitations for straightforward load cases, analysts can make reasonably good predictions.

While 3D FE soil-structure interaction analysis is readily achievable, the number of elements required to present solid piles in a large pile group can be prohibitive. Most analysis packages allow each pile to be represented by a beam, with limits set to represent friction and end-bearing capacity. Complete building loads, substructure and pile cap can be suitably modelled and overall foundation performance predictions are found to be good providing the data used, particularly for the ground, is accurate.

5.3.3 Pile-assisted rafts

While many foundations are either simple rafts or end up as large pile groups, the benefits of both forms can be realised in a pile-assisted raft. This approach affords considerable efficiencies over the adoption of a fully-piled system, while using a raft to avoid excessive settlement.

In its elemental form, the pile-assisted raft can be envisaged as a raft with piles strategically placed beneath highly-loaded columns to reduce the overall load on the raft and limit settlement. However, the full benefit is realised when analysis is able to reasonably predict the portion of load carried by the raft and by each pile.

Analysing pile-assisted rafts is complicated by a three-fold load path, with the building load applied to the top of the raft, transferred in turn to the piles, being stiffer than the ground, and then to the soil beneath the raft as the piles settle. The load in the ground then increases the stress induced on the piles themselves.

While 3D FE soil-structure interaction software has aided comprehension of the complex raft-pile-soil interaction system, inevitable uncertainties related to ground parameters should still be addressed by varying these values as part of the design process.

In summary, pile-assisted rafts offer an economical foundation solution in many situations. To some degree, risks associated with variance in analysis and field performance are offset by the composite approach, while adoption of a raft also potentially offers a reduced factor of safety to guard against unexpected pile failure.

5.4 Basement design

It is common to construct basements in conjunction with tall buildings, often extending well beyond the footprint of the tower itself. The issues relevant to this situation are broadly similar to that for any basement work, namely:

- Retaining the surrounding deposits during excavation and post-construction.
- Ensuring movement of the ground beyond the basement footprint does not cause damage to surrounding buildings and infrastructure.
- Controlling groundwater inflow and uplift pressures during construction.
- Providing a waterproof substructure.
- Either resisting water uplift pressures or under-draining the basement.
- Resisting any long-term heave exerted by the ground.

Elements that can be seen as relatively unique for tall buildings are:

- Ensuring slab continuity across the basement to resist lateral soil and water pressures.
- Controlling the impact of slab shrinkage and creep 'pulling in' the permanent basement walls.
- Accommodating the significant load changes occurring at the perimeter of the tower footprint - develop a transition zone, ensuring no abrupt change in raft/slab thickness or reinforcement so as to prevent localised cracking.

Due to the many parameters set out above, it is difficult to give precise guidance on issues relating to basement construction in tall buildings. However, general guidance on the design of concrete basements can be obtained from The Concrete Centre publication: *Concrete Basements*, CCIP-044 [3].

6. Buildability

Early contractor involvement is essential to inform the decision-making process within the design and detailing of tall buildings. With the design team and contractor working in partnership from an early stage, fundamental choices affecting the design can be made, such as core construction methodology, tower cranes, access (hoists and stairs) and screens. In addition, early collaboration affords time to ensure the most advantageous construction sequence can be realised, developed and understood by all parties.

The main drivers for contractors are:

- Safety of site operatives and the public
- Crane utilisation
- Incoming logistics, laydown and storage areas
- Vertical movement of operatives and materials
- Standardisation of structural elements and components which leads to repeatability of forming.

6.1 Core construction

The formwork system used for core construction needs to be considered integrally with the crange and logistics solutions for the construction, including the relative position and height of core links to the cranes. If the crane is tied to the core, the two can progress together, whereas if the crane is tied to the slabs, then the core and crane progression will be directly linked to slab progress.

Structural engineers and contractors should engage in workshops from an early stage, enabling restrictions on the height of the core beyond the following slabs to be fully understood by all parties. It may be necessary to re-examine the foundation solution to ensure it can cope with the different load case when the core has been jumped in advance of the rest of the building.

Figure 6.1
High-rise construction.
Photo: Laing O'Rourke Plc.



Table 6.1
Core-forming options and some key attributes.

Attributes	Crane climbed jump-form	Self-climbing jump-form	Self-climbing slip-form	Self-climbing intermittent slip-form (Stutterform)
Concrete finish and density	Good	Good	Requires making good	Requires making good
Concrete required	Early age strength for cycle times	Early age strength for cycle times	As per structural requirements	As per structural requirements
Concrete placement	Skip or placing boom	Skip or placing boom	Skip	Skip
Wall thickness range (typical)	200-800mm	200-800mm	200- 450mm	200- 450mm
Frame-to-core connection	Embedded plate or cast-in couplers or pull-out bars	Concrete corbel or embedded plate or cast-in couplers or pull-out bars	Embedded plate or cast-in couplers or pull-out bars	Embedded plate or cast-in couplers or pull-out bars
Average cycle time	4 days	4 days	250mm per hour	250mm per hour
Craneage required	Very high demand	Moderate demand	High demand	High demand
Can work continue below (hanging platforms)	Yes	Yes	Yes	Yes
Special considerations	N/A	N/A	24/7 working required to realise advantages of system	Slipform started each morning then stopped each night to avoid 24/7 working - requires heavily retarded concrete

Figure 6.2
Schematic of the self-climbing jump-form system
Image: Select Plant Hire Limited & Laing O'Rourke Plc.

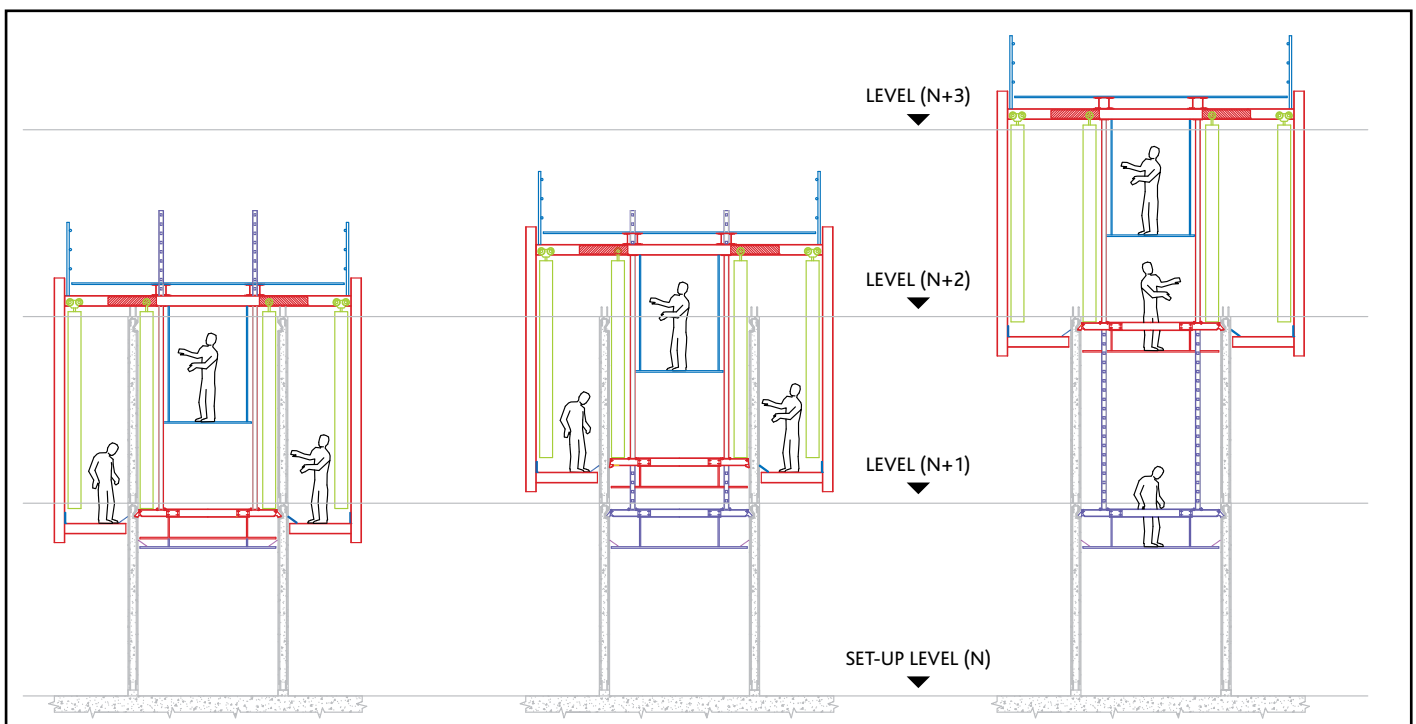

Figure 6.3
An example of a crane-lifted jump-form.
Image: Peri Ltd.



Formwork systems for core construction

All of the systems can accommodate changes to the core wall thicknesses but these should be minimised. Refer to Figures 6.1, 6.2 and 6.3.

With all of the outlined systems, a level of integration is required between temporary and permanent works. The plan layout of the walls, floor-to-floor heights and location of any penetrations needs to be frozen at an early stage.

Although these are standard formwork systems, early engagement can lead to a more refined system. The aim is to cast as many of the structural elements in the initial pass as possible and minimise any return visits or trailing platforms. Further refinements can be made to install precast stairs through the formwork systems. Again, this needs to be fully understood by all parties to ensure that a core being progressed in advance of the rest of the structure has the necessary stability.

Additional pockets and cast-in plates required for any of the systems need to be coordinated, as the preferred location may not be possible due to the design of the core. Typically these pockets should be considered as penetrations and detailed as such, but there will be a need for additional reinforcement to accommodate concentrated loads.

Detailing needs to reflect the sequence of core construction, as some walls and slabs may be cast from a trailing platform. The structural connection between these elements needs to be fully designed to allow accurate detailing. Beams within the core walls need to be considered early to allow efficient placement of rebar through layering and orientation of bars.

Figure 6.4
An example of a slip-formed core
 Photo: Laing O'Rourke Plc.



Standardisation is of key importance to increase repetition, quality and, subsequently, output. Use of an experienced reinforcement detailing specialist for the cores is highly recommended. Discrete precast components, vertical or horizontal elements may be incorporated into the in-situ core construction as it proceeds. This can assist buildability and improve cycle times.

Consultation between structural engineers and contractors must take place to ensure contractors can 'pre-set' building levels to account for any settlement and axial shortening of structures over the construction phase. Sequence and loading at every point within the programme must be fully understood and calculated.

Element levels at each floor will need to be cast higher than the desired final level by a variable amount predicted by theoretical calculation. Contractors will need to monitor all element levels at each floor regularly as construction advances, and report these to designers for comparison with theoretical and target levels and potential adjustment based on actual movements. If conducted collaboratively, using the same approach as the original design, an improved result can be achieved. Further guidance on presetting and monitoring the structure during construction is provided in Chapter 11.

6.2 Column and wall construction

In addition to vertical elements within core construction, the construction methodology for any columns and additional walls should be determined. The advantage of precast concrete here is that it minimises hook time and risk from adverse weather, with the associated time savings likely to outweigh any potential increase in costs.

However, if precast is not a viable solution, an on-site solution can be used. To choose the appropriate methodology, impact on craneage and lay-down must be considered.

It may be beneficial to prefabricate the rebar and then lift it into place, possibly using double height cages to minimise the impact on craneage, while slab-to-column connections should be considered to ensure buildability.

For a double-height pour, the formwork would require more hook time as it would not be light enough for manual placement. If single height is utilised, then a lightweight formwork solution would be appropriate but due to craneage and economies of scale, it may be more prudent to fabricate bespoke shutters offering the advantage of being a single-lift item to the exact project specifications.

It is important to achieve standardisation in column section sizes, with changes minimised to ensure formwork re-use rates are high. A preference would be to reduce rebar content or concrete strength and then have the changes in section on set floors pre-agreed with the contractor. The walls should be treated in a similar manner, with precasting, prefabrication and formwork solutions all considered.

Reinforcement cages can be prefabricated offsite and brought to site on a just-in-time basis, and detailing should reflect this, wherever possible.

6.3 Slab construction

Consideration should be given to the structural form of the slabs, and its impact on construction. General guidance, irrespective of structural form, includes:

- In-situ floor construction has commonly been adopted for high rise concrete structures. However precast or precast/in-situ hybrid floor construction systems should be evaluated for their potential benefits in terms of programme cycle times, safety and quality. The implications in terms of crane-hook times must be assessed.
- For in-situ floor construction, flat slab design has buildability advantages with drop/edge beams and thickenings minimised. Precambers should be avoided if possible but if necessary, should be standardised so falsework can be designed to suit.
- Pour sizes should be as large as possible with maximum pour size determined by rate of concrete supply and the finish required. It may also be informed by working-hour restrictions.
- Slab depth influences material usage, cost and weight. For example achieving a 25mm saving in slab thickness over 50 storeys also equates to a 1.25m saving in height.

For in-situ slabs, options include reinforced concrete (RC) or post-tensioned (PT) construction. If PT is chosen, particular care should be given to:

- Temporary movement joints and pour strips
- Tensile shortening of slabs inducing restraint cracking in edge columns
- Slab deflections
- Fixing points for the façade and any cast-in inserts which will need to be coordinated with stressing anchors.

Contractors may prefer a PT option as it can provide quicker cycle times for the falsework and minimise the weight of reinforcement within the slab.

Alternatively, a hybrid in-situ/precast system may be adopted. Common products include:

- Lattice girder planks for the entire slab can provide a high quality finished soffit. It is not suitable, from an architectural perspective, for all end uses. Although it provides permanent falsework, propping is still required at a reduced quantity. It may be that these loads inform the permanent works design.
- Lattice girder with in-situ beams can be more economical than an entire lattice plank slab but requires more falsework.
- Hollow core slabs' finish is generally inferior to a RC slab and may need to be made good or covered. Speed of installation is high with little temporary works requirement, although the connection to vertical elements is restrictive and may require additional items (steel angles) or for cores to be left open to allow for tying in.
- Double T Units provide a fast solution, able to cope with large spans with little temporary works requirement. It is necessary to ensure the slabs are tied into the core efficiently and diaphragm action has been accounted for.

An early decision is required on which reinforcement type will be used to inform the detailing, whether loose bars, rollmat or specialist mesh. Standardisation needs to be investigated to ensure flexibility, quality and speed, and prevent the fabrication process and delivery from holding up site progress.

Each option will require different amounts of crane time, with a hook time analysis to be carried out in combination with a cost/benefit analysis of the various options. For example, if rollmat proves to be expensive, standardisation of loose bars and the associated L and U bars may be preferable.

6.4 Slab formwork for in-situ concrete slabs

Working within an enclosure system determines the formwork solution. Vertical movement of the formwork will be by load-out platform or an integrated formwork hoist; the sizes of which determine the maximum formwork table size. Therefore, either a mobile table solution or panelised soffit system would be applicable.

A further determining factor in choosing the formwork solution would be material movement paths. Vertical elements within the permanent works may mean mobile tables cannot be used. Panelised soffit systems are more robust and require little work at height, as they can be erected from below.

Formwork systems often include a cantilever section of formwork/falsework at the perimeter to provide access beyond the slab edge. The associated falsework frames will generally need to be tied down to the preceding floor slab to prevent them from over-turning and falling out of the structure.

Cast-in items

Cast-in channels will need to be cast-in for cladding and other follow-on trades. Channels sitting on the soffit can be easily accommodated and held in place but channels on top of the slab require ski supports from the formwork. The channels should be supplied by the specialists using them, along with the relevant setting-out information. Cast-in channels should be coordinated with stressing anchors where PT slabs are adopted.

Figure 6.5
Integrated enclosure system
and load-out platform

Photo: Laing O'Rourke



Slab edges

Prefabricated steel forms may be preferable to timber shutters and should be made off-site in relatively short lengths for man-handling and moving between levels in the formwork hoist or load-out platform.

Alternatively, precast concrete edge units could be adopted, offering the advantage of accommodating cast-in items (such as channels or stressing heads for post-tensioned slab) very easily and accurately. Workshops should be held to ensure all parties understand any requirements to move the nominal slab edge and overcome any effects of axial and elastic shortening.

6.5 Cranage

Tower-cranes will be jumped and tied into the structure as it progresses. A specialist tower-crane supplier with experience in tall buildings should be consulted at an early stage to ensure temporary tie loads, which can be significant, are fully coordinated with the permanent works. The tie could either be back to the core (for a crane within the core) or the slabs (for a crane external to the building). See Table 6.2.

Table 6.2
Crane options.

Typical options for crane position	Additional loads	Potential issues
External to building footprint	Tie loads to slabs or external walls of core.	Coordination with cladding. Difficult to make the building watertight.
Within core	Crane jacked up within core so all loads are transferred back to core walls.	Sequencing to be examined and monitored to ensure core construction is not halted whilst waiting to jump the crane.
Hanging from core formwork	Formwork loads dramatically increased; these will be transferred back to the core walls.	Increases the cost of the formwork due to the increased loads. Can only be used with self-climbing formwork.

Coordination will need to extend to the specialist cladding contractor to ensure the ties allow the cladding to commence and the building to become watertight at the earliest available opportunity. Removal of the ties must be fully considered as part of this exercise. Coordination of the pre-welded jumping lugs and the ties back to the structure must be carried out, as this may become an issue when dismantling the crane.

Climbing can take up to four days but typically can be completed in two, if deliveries are effectively scheduled and a suitable weather window is selected.

The interface between the counter-jib and the core formwork needs to be considered. With the sway of the mast increasing as the height increases, it may become an issue as construction progresses. Consideration must be given to climbing time for crane drivers. A sensible solution is to have access points at the ties back to the superstructure. This allows drivers to use the passenger hoists as high as they can and climb the final section.

Figure 6.6
Tower crane ties to structure.

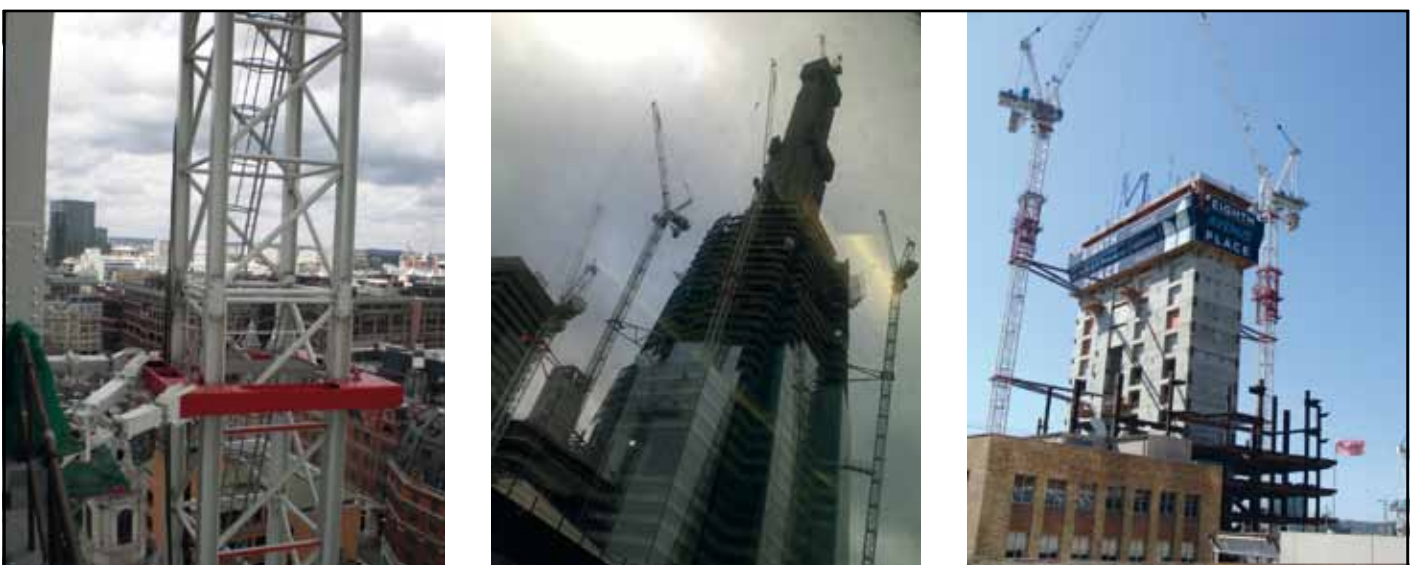

Hoists

Hoists can be internal to the core or external to the building. A hoist is required in the core to service the core formwork system. However, sectional handovers may require the hoist to be jumped up within the core to allow follow-on trades to commence work. The hoist would then sit on a grillage suspended at a higher level transferring additional loads back to the core and would then require additional external hoists.

While internal hoists are not weather-dependent and users are less likely to be nervous compared to travelling in an external hoist, the interface with a formwork system and an internal hoist would need to be coordinated to ensure clashes are eliminated. For an external hoist, tie loads and locations require coordination, with the impact of these discussed with follow-on trades, particularly cladding, to ensure minimal impact on the programme.

Additionally, a formwork hoist integral to the screens - similar to a load-out platform but also an elevator and typically covering five levels to allow swift movement of materials - can be used. It is hydraulically-driven but needs careful consideration for delivery as the rails are typically greater than 20m long. There will also be several floors of back-propping or a locally-stiffened slab to accommodate these loads.

The hoist may be seen as an unnecessary expense but it reduces reliance on the tower crane, thus further de-risking the activity and making it less weather-dependent.

Enclosure systems

Enclosure systems (screens) are required to fully enclose the working areas, and are essential for the safety of the workforce and public. These systems can be hydraulically jacked to ensure hook time is minimised. Delivery and logistic issues need to be thoroughly examined to ensure there is room on site for assembly. These systems can also be delivered to site fully assembled.

Bespoke systems specific to the slab layout and thus minimising gaps can be manufactured and, while expensive, offer an advantage if there are multiple corners or steps in the slab. Back propping to the slab edge may be required unless the slab is sufficiently stiffened to accommodate the increased loads.

Levels beneath the screens may require closing off with netting or full height guards, both of which require maintenance.

Design coordination should happen early to ensure tie loads and locations are allowed for, and are not detrimental to follow-on trades. It may be necessary to add buffer rails to prevent straps and chains snagging on the screens when installing cladding units on levels below.



Figure 6.7
Hydraulic self-climbing enclosure systems for core and slab construction.
Photo: Laing O'Rourke Plc

6.6 Concrete placement

Cores are generally poured via self-erecting placing booms using a high-flow mix with a rapid early-strength gain (typically C50/60). Use of the cranes to place concrete via a skip must be minimised.

Slabs are poured using a large static pump with a line running up the building, tied to the core. Typically a C32/40, S3 or S4 mix would be used. Early engagement with ready-mixed concrete suppliers is necessary to ensure mixes are fully developed and trialled, particularly for pumping through multiple floors. In addition, it may be advantageous to use in-situ thermal monitoring and maturity methods to improve striking times.

Concrete using lightweight aggregates can be problematical for long-distance pumping and concrete finishing, and should be explored in detail with contractors and concrete suppliers before specification for use in tall buildings.

6.7 Tolerances

Local codes of practice and standards may not always provide relevant guidance on tolerances (the position in which the elements of the structure are cast) for high-rise construction. Construction tolerances are deemed to be pre-strike and do not include movement or deflection after removal of formwork/falsework, or medium- to long-term settlement, shrinkage, creep, shortening or thermal effects.

For general guidance purposes, core tolerances of ± 25 mm in overall position and ± 15 mm in verticality per storey and pre-strike slab level tolerances of ± 10 mm are likely to be achievable. The achievable tolerances should be discussed with local contractors prior to finalising the project movement and tolerances report.

Tolerance issues can be exacerbated through the choice of lightweight concrete, as both pumping and finishing can be more difficult and time-consuming.

Surveying teams need to carry out as-built surveys as quickly as possible to ensure there is enough time to agree and complete remedial solutions without any impact to follow-on trades. It is good practice to monitor foundation settlement during the construction phase against sufficiently remote datums, which are unlikely to be affected by the building construction. Also it may be appropriate to undertake monitoring of adjacent structures to establish any effect caused by high-rise construction activities.

7. Loading

The dominant loads on tall buildings are lateral horizontal wind and seismic loads; the magnitude and predominance of which are determined in accordance with the appropriate loading code. Accurate determination of these forces and effects is critical to the development of framing systems, and evaluation of the size of the main structural members.

As with all structures, the vertical elements need to accommodate the worst combination of gravity and lateral loads. Although the gravity loads will be large – particularly in very tall buildings – wind and seismic loads, acting on what is essentially a large vertical cantilever, dominate assessment of structural sizes for the preferred lateral framing system and will necessarily inform the architectural layout and spatial arrangement.

The size of the building will typically determine the structural system. Although several configurations may be open to structural engineers, experienced engineers have a good understanding of the typical 'rules of thumb' for the proportioning of the various elements. Preliminary analysis is, nevertheless, required during the early phase and should entail a rough evaluation of the lateral and gravity loads.

From this preliminary information, the size and layout of structural framing elements will be developed in conjunction with architects. More detailed and thorough assessment of all loads will normally be carried out in subsequent project phases.

Designers must consider all applicable dead and imposed loads for a building, including pattern loads and temperature effects. Having evaluated the often large range of individual load cases, designers should assemble a full complement of load combinations for overall stability calculations and ultimate limit state (ULS) designs.

Gravity loads

There are two types of gravity loads - static and dynamic. Static loads are relatively constant and unchanging over a long period up to the life of the building. Dynamic loads are time-dependent and typically vary between a series of upper and lower values over a relatively short period of time. They are usually only considered in the evaluation of the dynamic behaviour of floors.

Static gravity loads are further split into dead and imposed (live) loads. Dead loads are permanently applied to structures for the life of the building, such as main framing elements and services fitments. Imposed loads are produced by the intended occupancy use, including the weight of movable partitions in office buildings.

Snow loads are of relatively low significance for the global design of a tall building, given the typically small surface area of the roof, or even of multiple roofs. As expected, and similar to the design of shorter buildings, the local effects of snow loading on exposed slabs and parapets need to be considered.

Wind loads

While preliminary wind loads for tall buildings can often be determined from the appropriate code of practice, for a more detailed building analysis or if a building is very slender or has complex geometries, it is common for designers to procure a wind tunnel test. For further information, see Chapter 9.

Whilst the magnitude of gravity loads will directly affect the size of the main structural elements, they should also be considered as part of the global restoring force in the overall building stability equation, when evaluated against the overturning forces at the base of the building.

The great advantage of tall concrete buildings is their inherent self-weight which serves to naturally enhance structural stability. This mass and the contiguous nature of the construction of concrete framed towers also provide a greater degree of structural damping, dissipating cyclical sway from lateral forces.

Seismic loads

While seismic loads act in a lateral horizontal and vertical direction, horizontal loads are typically more significant for tall buildings. If considered significant and controlling in respect of the overall structural frame, seismic loads can usually be idealised as equivalent static lateral shear forces or, for taller or more slender frames or where the ground conditions dictate, as a load or response spectrum. Further reading of Chapter 10 and the applicable code of practice, in conjunction with specialist texts and papers covering current practice, is recommended.

7.1 Dead load

Dead loads acting permanently on the structure can typically be calculated with a high degree of accuracy, even at the early preliminary stages of a concept design. Dead load is made up of the self weight of the main structural elements and the permanently-applied building fixtures and fittings.

As with any other building design, estimation of the dead loads is relatively straightforward and, although minor inaccuracies can occur, early assumptions of material weights and elemental loads can be adjusted and corrected during the detailed design phase to ensure accuracy of the final solution.

The structural self weight of the floors, columns and walls and other main members is a function of the three-dimensional size of the structural elements and the known or estimated material density. The superimposed dead load will account for permanent fixtures including:

- Floor finishes and topping screeds
- Non-structural walls and finishes
- Cladding loads
- Raised floors and ceilings
- Building services fitments such as electric lighting, under-floor heating and permanent ductwork.

At the preliminary or concept design stage, many of the final weights of various elements such as screeds and cladding are yet to be determined. While every effort should be made to accurately evaluate these weights, resources are available to aid early assessment.

Designers can give consideration to the application of reasonable 'extra-over' allowances until such time as the actual weights can be confirmed, but note that care be taken not to over-estimate the dead loading and then rely on it for the lateral stability restoring moment.

7.2 Imposed load

Imposed or live load is a gravity load specified in accordance with the occupancy of the space and its intended use. The imposed load is typically defined as a uniformly-distributed gravity load acting downwards onto a floor area and affects the design of all buildings.

For the overall lateral stability assessment, it is usually adequate to only consider the general area live loads but in certain areas, such as plant rooms and parking areas, the final design of individual elements may depend on the application of the appropriate concentrated live load case associated with use of the space.

The theory of statistical probability in relation to the variable nature of imposed loadings on a structure confirms the unlikelihood of the full intensity of the code-prescribed live load acting simultaneously at any plan position up the full height of the building for the entire life of the structure. As a result, loading codes allow for live load reduction; typically expressed as a percentage reduction of the main loads and evaluated according to the number of floors or the relative areas in the building.

Reference should be made to the appropriate code of practice for imposed load allowances and reduction factors typically tabulated in accordance with building type and usage. Structural designers should also refer to latest guidance on long-term 'realistic' floor loads suitable for use at various stages of the design.

7.3 Load combinations

All structures are subjected to gravity loads acting downwards and lateral loads acting in different horizontal directions. All relevant combinations of the worst case load effects must be checked.

Serviceability combinations are used to check global lateral stability deformations or drift. In a similar manner, un-factored load cases are combined to establish the sizes of building foundations, whether they are deep-piled or shallow-spread foundations, as per traditional design practice.

Design of individual reinforced concrete elements for all buildings is typically based on ultimate-limit-state combinations. In accordance with the provisions of this ULS method, the reduced or factored design capacity of the structure or element must be greater than or equal to the worst case combination of the ultimate-design load effects.

The relevant code of practice will normally provide several load combinations, with different load factors relating to the nature of the load and the type of combination. All applicable combinations must be checked in the detailed design phase; often by using 3D finite element design packages.

In smaller buildings, the worst case loading condition is often ascertained by an intuitive investigation of the frame arrangement. However, for the design of tall buildings, the critical combination depends largely on the building frame and bracing characteristics. Furthermore, the combination producing the worst case effects in one critical element may not necessarily produce the worst case loading condition in another separate member.

Where applicable, for the design of individual slab elements, pattern load distributions of the imposed loads should be applied to alternative spans, in accordance with the relevant code recommendations.

For particularly slender buildings, more prone to vortex-shedding excitation, wind tunnel testing should almost certainly be considered for the evaluation of final design wind loads. This type of detailed testing can also help to define adjustment of the standard load factors from some codes of practice. For further guidance, see Chapter 9.

7.4 Construction loads

Consideration of construction loads in the early stage of the design process is of great importance. In some cases, construction loads are greater than loads applied to the building over the entire life of the structure, particularly at the podium and basement levels but also on the upper suspended tower floors where spaces will be used for lay down and materials storage. Reference should also be made to Chapter 6.

Incorporating construction load in design plans

Although many temporary works and associated construction loading aspects are the responsibility of main contractors and frame contractors, it is important for design documentation to clearly indicate loading allowances. Greater imposed load allowances can be catered for in the structural design, allowing floor back-propping to be removed faster than normal, freeing up valuable site space and access routes, or opening up areas for finishing trades.

This is particularly important in relation to the construction of typical upper-floor slabs. Depending on construction methods and framing system, the floor-to-floor casting cycle could be as fast as four to five days, although this varies considerably with each project.

A newly-cast concrete floor slab will typically lack sufficient strength to support the weight of the falsework, formwork and wet concrete of the next slab up (or possibly the next two or three slabs higher up). To mitigate the risk of misunderstanding and mistaken responsibility between design teams and contractors, and ultimately ensure slabs are not damaged, it is imperative for the construction methodology to be clearly established as early as possible. This point is particularly relevant for 'design and build' projects, in which the engineering team is directly engaged by the contractor.

Where the chosen construction sequence requires the core to be advanced well beyond the floor slabs, the designer will be required to consider the associated temporary load case. This is particularly relevant where the core is tied in the permanent condition with link beams, but not tied in the temporary condition. Depending on the arrangement, the movements and forces generated may require alterations to the design of some elements, or detailed consideration of the proposed erection sequence to mitigate adverse effects.

Load impact from temporary tower cranes

Another critical load aspect with a potentially significant effect on the design of various building elements is the placement of temporary tower cranes. Cranes are usually seated on piled, reinforced concrete bases cast integrally with the basement works and, in some cases, may also be fixed back to the core or the slabs at various positions up the height of the building. The associated loadings should be considered within the structural design.

Unfortunately, detailed design information for these temporary works elements is usually only provided after much of the detailed design work has been completed, requiring adaptation of design documentation.

For evaluation of the various factors relating to the construction methodology of tall buildings, it can be beneficial to procure early contractor involvement services, whereby a main contractor with an appropriate level of experience in tall building construction would work with the design team.

Figure 7.1
Loading from construction materials and activities may be the dominant imposed load.



7.5 Accidental loads and disproportionate collapse

As with all building structures, tall buildings should be designed to avoid disproportionate impact from accidental action. In most building codes, a weighting is placed on the consequence of failure and tall buildings will generally fall into a high consequence class in terms of potential loss of life. As a result, codes typically require an assessment of specific risks of accidental damage and making a proportional provision in the design. The approach to avoiding disproportionate collapse should be agreed with the approving authority.

Incorporating general robustness in design

Although attempts have been made to design buildings for particular accidental events, such as a notional aircraft impact, this approach is not generally recommended. It is considered better to incorporate an appropriate level of general robustness in the structural design concept and detail, by meeting codified tying requirements or designing the structure to remain stable following the removal of any one structural element. Any element fundamental to the stability of the structure is designated a 'key element', requiring special attention in design to ensure it will remain in place.

Simple application of codified tying rules will not always be sufficient for tall buildings falling within the scope of this document. However, the project specific risk assessment may establish that an adequate level of robustness can be achieved using tying principles. Horizontal tying ensures vertical loadbearing elements are tied into floor diaphragms to prevent the vertical element being blown out leaving the floor without vertical support, while vertical ties are provided to ensure columns are continuous and in the event of a lost lower column, the column above will act as a hanger suspending an area of floor from above.

Static analysis of a structural model

Typical practice for checking element removal will involve static analysis of a structural model without the 'removed' element. In practice, removal of an element in an accidental occurrence could lead to significant dynamic magnification, depending on the failure mechanism of the element and the structural system relied upon to support the structure following removal. This can be allowed for by applying a dynamic magnification factor to the calculated loading, with engineering judgement required to arrive at an appropriate factor.

A key element, the removal of which could lead to collapse of the structure or a significant part of it, is typically designed to withstand a codified over-pressure or impact load considered as an accidental load. Where risk assessment shows that code standard pressures or impact may not be sufficient, these will need to be increased accordingly. Transfer structures, such as deep beams carrying columns from above, will commonly fall into the category of key elements.

7.6 Temperature loads

Temperature loads are particularly important to consider in relation to elements of the structural frame outside of the cladding line exposed to the elements; cooled or heated daily or seasonally. As typical design combinations are notionally carried out on structures at an ambient temperature of, say 20°C, engineers need to determine recommended positive or negative temperatures for application to various elements in combination with the other main load cases.

Given variability in potential conditions at the time of construction, and the nature of appropriate environmental conditions and time-dependant changes in the internal (through-thickness) temperature of the structure, establishing a realistic set of temperature parameters for design is not straightforward.

As with the design of all buildings, some combinations such as snow loads with increased temperature cases will become redundant. However, depending on the geographical location and exposure of various elements as well as the framing system, temperature load cases can result in the worst case moments and forces for some elements.

Temperature as a self-straining load

Temperature loads are fundamentally different from other externally-applied loads such as imposed gravity or wind loads, as they are self-straining loads. While an indeterminate concrete structure has the capability to redistribute its load resistance based upon the relative stiffness of structural members in the frame, the structure as a whole must come into static equilibrium with externally applied loads to remain stable.

Applied loads are wholly independent from the characteristics of the structure itself. In the case of self-straining loads, the applied 'loads' are at least partially related to the characteristics of the structure, resulting as they do from volumetric changes in the member itself.

Other common sources of self-straining 'loads' and stresses, besides temperature change, are differential foundation settlement, and the effects of creep and shrinkage.

Stresses developing in structural members due to self-straining type 'loads' are a function of stiffness of the member, and of any other member providing deformation restraint to the member in question.

In the case of a restrained reinforced concrete structure subjected to a change in temperature, axial stresses develop as a function of the member stiffness or modulus of elasticity, the coefficient of thermal expansion of the concrete and steel, and the magnitude of temperature change. In the case of a temperature reduction, as the member attempts to contract, stresses develop due to the restraint condition with the resultant tensile stress carried by the concrete section. Once the tensile capacity of the concrete is exceeded, cracking will initiate, reducing the stiffness of the member as it transfers internal stresses to the steel reinforcement, with the result that stresses are effectively relieved as cracking develops.

Accurate predictions are problematic

Prediction of self-straining stresses becomes quite difficult due to the inelastic behaviour of reinforced concrete once cracking has been initiated, making it often impractical to design for such stresses.

It is considered best practice to design structures to minimise or avoid development of member stresses due to self-straining 'loads'. In the case of thermal loads, this can be achieved through the introduction of expansion/contraction joints, and by enclosing the reinforced concrete structure within a thermally controlled environment, providing this fits with the overall design proposals.

If this cannot be achieved, the design must account for internal stresses and cracking that may arise in the members, with accuracy dependent on analysis taking into account the nonlinear nature of the material stiffness.

A purely elastic analysis will be overly conservative for the strength design, and in many cases will lead to highly uneconomical designs but conversely may be very unconservative for serviceability if the stiffness-reducing effects of cracking are not considered.

8. Building dynamics

Serviceability limit-state (SLS) design checks are a key aspect in the total design of tall buildings, and careful studies should be considered as routine during the early stages of any project. Lateral stability and gravity load-resisting elements must be planned and designed to resist worst case ultimate load effects, and to maintain adequate function or serviceability for occupants. With the continual advancement of design and construction practice, tending towards more flexible structures as better materials are used more efficiently, it is not uncommon for serviceability limit states to govern the structural design of tall reinforced concrete buildings.

Wind and seismic loads are the primary lateral loads which must be resisted by tall buildings. Wind forces are more frequent than seismic forces and may govern the design of tall buildings in most, but not all, geographic locations at both serviceability and ultimate limit states. Engineers must understand how tall buildings respond during loading events to avoid adverse behaviour.

Effect of lateral forces on tall buildings

Tall buildings are, in effect, vertical cantilever beams, and will naturally respond to lateral forces by moving in the direction the force is applied, and since wind and seismic forces are not static, the structure will tend to sway back and forth as a result. Lateral loads are applied in varying degrees and often in roughly repeated cycles over any given period, for example, gusting winds in a storm. Regardless of whether the loads are applied as individual or idealised one-off events, or as a repeated or cyclical event, the result will be building motion which will require consideration during the design phase. The structural system and building weight will play a large part in how the building responds, as will factors such as the force direction, force magnitude, building height and foundations.

Natural damping qualities

Tall buildings formed of in-situ reinforced concrete have an inherent degree of natural damping, the measure of a structure's ability to dissipate energy. Natural damping can have a significant effect on the performance and response of buildings, and should be considered at an early stage in the design. Damping values are typically quoted as a percentage of critical, defined as the damping required to bring the motion to rest after only one cycle. During the early stages of design, it should be possible to prepare a simplified building analysis model enabling early examination of building frequencies and modal response, using a range of tools, from hand calculation techniques through to 3D modelling using specialist software. Use of more sophisticated tools is recommended for slender tall buildings.

In some cases, it may be appropriate to specify auxiliary damping devices to satisfy serviceability limit states but this must be considered in the context of building form, construction and maintenance budget, whilst balancing client aspirations with functionality and serviceability. Early identification of resonance problems, potentially requiring some form of additional damping or energy dissipation system, will allow costs for auxiliary systems to be assessed and approximated in the cost plan.

8.1 Damping

Damping is a measure of a structure's ability to dissipate energy. Tall buildings formed of in-situ reinforced concrete have a relatively high degree of natural damping, compared to steel or composite steel and concrete structures. Damping has a significant effect on the dynamic performance of a building and is the property which limits resonant displacement build-up under repeated wind or seismic loadings.

All of the contributors listed below are indicative of sources of 'natural' damping in buildings:

- Inherent material damping of heavy concrete elements under elastic deformation.
- Additional material or mechanical damping due to inelastic deformation (for example, link-beam cracking).
- Damping provided by non-structural building components such as cladding/exterior walls and interior partitions.
- Possible aerodynamic damping due to the interaction of the building motion in the wind, although in some cases this could also be negative.

A higher level of damping and, thus, increased energy dissipation has the effect of reducing the lateral acceleration response of the building in wind or seismic events. To achieve a reduction of the lateral acceleration response (for example, to satisfy occupant comfort criteria) would require optimisation of the structural system to increase stiffness or changing the aerodynamic properties and/or shape of the building. The latter would require very close collaboration with architects at the earliest project stages, even before the building form has been fully agreed upon.

Alternatively, higher levels of damping can be achieved using auxiliary damper devices. Without their use, it is not typically economical to markedly change the levels of damping in a structure.

Contribution to total damping from non-structural components is difficult to quantify, is representative of only a small portion of the overall or total building damping and is considered unreliable as a source of damping.

Historical and on-going studies

There is a difference of opinion amongst many engineers as to the most appropriate damping values for tall buildings in any material, with limited data available; most of which is typically measured from low level or common wind events outside the range used for building design. As damping is amplitude dependent, bigger wind storms produce bigger displacements, increasing damping to an extent related to the means of deformation in the structural system. Damping also decreases with height and is, to a varied extent, dependent on many factors.

Gathering in-service data is problematic, with potential error in the instrumentation or methodologies for assessing the damping characteristics of buildings leading to ambiguity. Obtaining clean decay (synonymous with free vibration) of amplitude or acceleration data is particularly difficult.

To estimate lateral accelerations, total damping values in the range of 1.5-3.0 % of critical have historically been used for damping at service loads in reinforced concrete structures. There is no record of problems resulting from the use of these damping values but research into real levels of damping and acceptability criteria (Smith et al, 2010^[4], and Ellis, 1996^[5] and Suda et al, 1996^[6] and Kijewski-Correa, Baker et al, 2005^[7]) for lateral accelerations is significant and ongoing, and exhibits a range of results. There is, however, agreement that the upper end of this historical range is probably an over-estimation of the likely damping capacity for what would be considered normal ultimate-limit-state strength design.

Engineers must recognise that assessment of factors affecting the serviceability design of tall buildings is subject to significant error, for example, the amount of cracking is often over-estimated while the stiffness and Young's modulus are typically under-estimated. Estimates of the period of vibration of reinforced concrete structures may be out by as much as 20 % or more because of these assumptions, which might then result in conservatively higher wind load estimates due to the dynamic component.

Further data collection errors may arise if data has been collected on a 'gusty day', when the amplitude of motion is quite small and the level of damping will be low, and unrepresentative of typical design criteria.

Care should be taken in opting for values that are too low, as to do so may have a marked effect on the economics of tall building design.

Natural damping of reinforced concrete buildings

Concrete structures have higher natural damping than steel structures. The damping is produced, in part, as the concrete cracks and thus absorbs energy. Damping is, therefore, dependent on the amplitude of the movement, as for larger amplitude movements more cracking occurs and, thus, the natural damping is increased. In designing the structure the engineer, therefore, needs to use judgement to determine the appropriate value of damping to be used in the design/analysis.

Engineers will typically use different damping values for the serviceability design, such as estimates of accelerations, as opposed to ultimate limit state design where more cracking in the structure can be expected and tolerated. For the serviceability design, the wind forces will be based on more frequently experienced wind events, namely those with a short return period whereas for ultimate-limit-state design longer return period events will be used.

There remains much debate in the engineering community, even amongst experienced engineers, regarding what damping values are appropriate for any given structure. The selection of the damping value used in the design can be critical, as the impact on the design lateral forces can be significant. It is often prudent, therefore, to undertake a sensitivity analysis on the damping values used.

Historically, damping values of 2 to 5 % of critical have been used; however, more recent data has cast some doubt on the use of values at the higher end of this range,

particularly for the short-return-period events. Recent research projects have measured damping within real buildings and have indicated damping at and below 1 % (ref Smith, R. Merello, R. and Willford, M. 'Intrinsic and Supplementary Damping in Tall Buildings,'^[4]). It is noted, however, that the damping data was extracted for relatively common wind events in which the amplitude of movement and, thus, the total damping might be lower than for rarer (longer period) events.

Damping is also influenced by the structural framing system, building configuration, foundation system and the ground conditions; evidence also suggests that damping reduces with increased building height. Therefore, particular care and experience is required in selecting the damping value used in the design. This becomes even more critical and sensitive for super-tall buildings.

As a starting point for design, engineers undertaking the design of a reinforced concrete tall building, up to approximately 250 m tall, could consider the following damping values quoted as percentages of critical damping:

$$\begin{aligned} 1 - 10 \text{ year event (SLS)} &= (1.0\%* \text{ to}) 1.5\% \\ 700 - 1000 \text{ year event (ULS)} &= 2.0\% \text{ (to } 2.5\%*) \end{aligned}$$

* Possible alternatives are shown in brackets.

As the design develops the damping value used may be adjusted as the engineer considers the building height, in conjunction with the structural system, which could include a primary and secondary lateral system, and the deformation characteristics, which could be based on shear deformation or cantilever beam bending or a combination of both.

The figures above should be used as a guide only. Engineers undertaking designs of dynamically sensitive tall or super-tall buildings should make every effort to update their knowledge of the most recent research and debate surrounding this very complex topic. It may also be appropriate to contact wind engineers and wind-tunnelling experts, who may be able to offer guidance on the assessment or application of damping values.

Auxiliary damping

Auxiliary damping devices may also be used to significantly increase the level of overall damping in a structure and reduce the peak lateral accelerations. Either 'active' or 'passive' in nature, auxiliary dampers are typically not considered as the first option in reducing building motion but are increasingly specified in the design of tall buildings, particularly when project constraints limit the viability of other means for achieving target serviceability criteria.

Active devices rely upon external controls to deliver applied loads in response to the motion of the building, particularly in situations where the seismic response of the building requires control.

In wind applications, passive dampers are typically more appropriate and rely upon their own mass and damping to counter-act the motion of the building so as to reduce lateral wind response. Common examples of passive dampers include tuned mass dampers, tuned liquid-column dampers and tuned sloshing dampers, with the last two usually considered first for reinforced concrete building applications.

Dampers in reinforced concrete buildings must have enough overall mass to affect the motion of the building (approximately 1 % of the modal mass of the building) and must allow for modification or tuning to the in-situ building period, once in place.

Types of damping devices

A characteristic of liquid-column dampers and sloshing dampers, both of which use water, is that they allow modification. Any auxiliary damping device necessarily requires physical space for installation and may add significant cost to the project and to future building maintenance plans. A building monitoring program is also typically required to assess the performance of dampers and determine if, and when, dampers require further tuning to achieve optimum performance.

As increased levels of damping generally result in a reduced dynamic response of the structure, reduced inertial loads and, thus, reduced member forces can also result. However, it is not common practice to consider the potential reduction in member forces from the introduction of auxiliary damping in the ultimate strength design of the structure.

Use of auxiliary damping is usually considered only as a means of satisfying serviceability limit states and even then must be reviewed in the context of the building form, and construction and maintenance budget. Due consideration must be paid to client aspirations while balancing the need to achieve a fully functional and serviceable building for the end user.

8.2 Occupant comfort criteria

Taller and more slender buildings present a unique serviceability limit state related to the occupants' perception of the building's lateral motion. Sometimes referred to as the 'habitability' limit state, it affects only the human inhabitants of the building rather than any mechanical function. Reinforced concrete structures inherently have relatively high stiffness, mass and material damping characteristics, all of which are beneficial in limiting the magnitude of building motion under the action of wind. However, for super-tall buildings above 300 metres, it is quite likely that this 'habitability' limit state may become a governing limit state in the structural design of the building.

The structure's natural periods of vibration for the first few lateral modes are useful indicators of the potential for wind-induced dynamic response of the building. For preliminary purposes, the fundamental building period can be estimated as equal to the height of the building divided by '46' or - following a North-American rule of thumb - equal to the number of storeys divided by 10. 3D finite-element-based analyses are commonly used to better estimate the structure's natural periods of vibration.

The analysis model should incorporate only elements contributing to the lateral stiffness of structures and should not be overly complex. The natural frequency analysis should give particular attention to:

- Joint stiffness and connection types
- Expected amount of service-level cracking
- Effects of P-Delta deformation
- Foundation stiffness
- Realistic estimates of expected imposed loads (mass).

Even the most detailed finite element analysis should only be considered as an approximation of the real in-situ building period of vibration, as reinforced concrete structures have an inherently high variability in their overall stiffness.

Some of the factors contributing to this variability include simplistic estimation of the real concrete elastic modulus and its change over time, difficulty in estimating the actual level of concrete cracking in the lateral load-resisting elements and the change in levels of cracking as the building loads change, together with the effects of creep and shrinkage. An under-estimation of building stiffness will generally lead to a conservative estimation of wind-induced dynamic forces.

In tall, slender structures, it is common for both the maximum lateral drift and peak lateral accelerations to occur in a direction perpendicular to the approaching wind direction (National Research Council of Canada, 2010). This is referred to as 'cross-wind' motion, and results from the effects of wake excitation due to the vortex shedding phenomenon^[8]. Further discussion on this phenomenon can be found in Chapter 9.

Human perception

The perception and sensitivity of humans to building movement and vibrations vary significantly and are dependent upon a large range of complex and unique physiological and psychological characteristics. This includes the individual's understanding of the physical phenomenon to which they are subjected, and their perceived fear of risk or injury.

In addition, a heightened sensitivity to the physical movement of the building may be triggered by visual or audible cues, or by the responses of other individuals. Factors other than physical motion contribute to overall occupant sensitivity and comfort level, including a person's physical position which include standing, sitting or lying down and the level or nature of their activity during periods of building motion.

These complex factors, combined with a lack of reliable data from practical testing programmes, make it difficult to develop concise and transferable building motion criteria to ensure occupant comfort. However, over the past few decades various organisations have developed limiting criteria for building motion. Lateral acceleration and torsional velocity limits, used in the dynamic study of buildings, should limit the risk of occupants perceiving the building motion as uncomfortable.

Examples of wind-induced motion criteria typically used in North America for 10-year return-period wind events are listed below as a percentage of the gravity acceleration, but these should be checked with current references (Ref: NBC and CTBUH):

Residential occupancy: 10 to 15 milli-g
Office occupancy: 20 to 30 milli-g

8.3 Building accelerations

In tall, slender buildings, the lateral (translational or rotational) movement of the structure subjected to wind load should be limited to reduce the potential for building occupants to perceive such motion and become uncomfortable. Reinforced concrete buildings have inherently high mass, stiffness, and damping properties which all help to reduce the potential for adverse building motion but, for very tall, slender towers, this may prove to be the governing design-limit state.

The National Building Code of Canada (NBC) ^[9, 10] describes the evaluation of the peak across-wind and along-wind accelerations at the top of buildings, recommending a range of formulae for preliminary calculations. However, wind tunnel testing will always provide the most accurate means of estimating expected levels of building accelerations due to wind and can also take account of the dynamic response of buildings and wind-structure interaction. In some cases this interaction, known as aerodynamic feedback, can lead to a reduction in the peak building response.

In recent years, a more commonly accepted practice, outside of hurricane-prone regions, is to base acceptability criteria and acceleration limits on more frequent wind events (for example a one-year event). As larger building motions occur rarely, they may be tolerated and accepted as a rare singular event and thus are not a good indicator of a breach, whereas more frequent events potentially causing discomfort are a better indication of a serviceability breach.

Developing acceleration-limit criteria

There is a general consensus of a clear relationship between a structure's natural period of vibration and the perception of building motion.

For example, if one building has a natural period of oscillation of five seconds and another 10 seconds but both buildings are oscillating at the same peak acceleration value, the building with the 5-seconds period has a rate of change of acceleration higher, or more abrupt, than the 10-seconds building. This higher rate of change of acceleration is likely to be more strongly perceived by the average inhabitant. This effect has been demonstrated quite distinctly through the use of motion simulation experiments, and is reflected in the latest developments of acceleration limit criteria. In addition, this frequency dependence is reflected in ISO 10137 criteria.

Some engineers have considered a 'performance-based design' approach to occupant comfort levels and building motion, requiring building owners receiving input from structural engineers to consider the desired performance levels for their building in order to establish acceptable levels of building motion and associated recurrence frequency.

This type of serviceability 'performance-based design' model is discussed in more detail in the Architectural Institute of Japan (AIJ) guidelines on occupant comfort criteria ^[11].

Options for reducing accelerations

If early predictions indicate lateral building accelerations are beyond acceptable limits, there are a number of options for reducing the accelerations. In most cases, an increase in the overall lateral stiffness is effective in reducing peak response accelerations. It is not uncommon for the lateral-force-resisting elements of tall buildings to be proportioned on the basis of serviceability criteria or stiffness, as opposed to ultimate strength.

An increase in the mass of the structure can also be beneficial in reducing building accelerations but should be considered in association with overall building stiffness, which may change as a result of the increased mass and period of vibration.

The cross-sectional shape of the building and characteristics of the exterior surface of the building can affect the way in which it interacts with the wind. Alteration of the aerodynamics of the structure or the incorporation of positive aerodynamic features into the building architecture, including the façade, may prove critical in the design development of tall and, particularly, super-tall buildings. Any alterations of this type should be confirmed by wind tunnel testing, and would typically require agreement with the architect and other designers.

9. Wind engineering

Wind engineering is – as defined by Dr Jack Cermak^[2] in 1975 – ‘the rational treatment of interactions between wind in the atmospheric boundary layer and man and his works on the surface of Earth’.

Modern tall buildings - often of non-conventional architectural forms - are becoming taller, lighter and slenderer and, therefore, more susceptible to gusty winds. Wind influences a number of tall-building design aspects including:

- Playing an important role in the design of its foundations and later-stability system
- Controlling its global deflection and inter-storey drift
- Dictating the level of comfort of people occupying the highest (and more expensive) floors
- Playing a key role in the design of the glazing/building envelope and façade system
- Changing both global and local wind flow patterns, potentially increasing the level of windiness around its base.

To optimise the design of tall buildings and minimise associated risks, specialised wind engineering studies with potential to inform the design process from its early stages include, but are not limited to:

- Wind climate
- Wind loading
- Vortex-shedding mitigation
- Auxiliary damping
- Cladding pressure
- Pedestrian-level wind environment/comfort
- Plume dispersion.

This chapter is limited to wind engineering studies directly linked with the strength and serviceability design of tall buildings.

What should trigger the need for a wind tunnel test?

Some of the parameters designers should consider to establish if the tall building currently under design is likely to be wind-sensitive include:

Slenderness Ratio: is the tall building slender? $h / d > 5$, with h being the height of the tall building and d being the narrower dimension of the its plan cross-section.

Structural frequencies: is the first cantilevering bending mode of the structure sitting at a frequency lower than $46 / h [m]$ ($h [m]$ being the height of the tall building in metres).

Mode shapes: do the first modes of vibration of the structure appear to be very three-dimensional? (Could the torsional behaviour of the tall building be of any concern?)

Nature of the area surrounding the site: is the tall building in relatively close proximity to a few tall structures of comparable massing and scale? (Could interference effects be of any concern?)

Limits of applicability of wind design codes (see also Chapter 13) should of course also be taken into consideration.

9.1 Wind climate

A relatively wide range of storm types can generate the extreme wind events driving the design of lateral-stability systems for tall buildings.

From a structural point of view, the most relevant storm types are:

- Synoptic winds (gales, fronts, depressions, extra-tropical cyclones etc.) typical of latitudes ranging from 40° to 60°
- Tropical storms (which may be of greater intensity) mainly affecting latitudes ranging from 10° to 30°.

Areas affected by tropical storms include regions facing the South China Sea, the south coast of Japan and the Gulf of Thailand (typhoons); the Coral Sea, north coast of Australia and Bay of Bengal (cyclones); and the Gulf of Mexico, Caribbean Sea and west coast of Mexico (hurricanes).

Working in a region vulnerable to tropical storms entails serious design implications. If two tall buildings identical in envelope and structure were placed respectively in Shanghai (China) – a region prone to typhoons – and in Jeddah (Saudi Arabia) – a region of much milder extremes, the former structure would experience, on average, wind loads and wind-induced accelerations respectively 1.6 and 2.0 higher than the latter.

The effect on tall buildings of relatively smaller scale meteorological events such as Shamal winds (common in the Persian Gulf), thunderstorms (often of short duration) and tornados (common in the US) still represents an open area of research in wind engineering.

9.2 Wind loading for strength and serviceability design

Distinct from other natural hazards such as earthquakes, the 'energy' associated with turbulent and gusty wind is localised at the low-end of the frequency spectrum (approximately less than 1 Hz) and shows a decaying trend as the frequency increases.

Wind aerodynamic force is the result of wind interacting with the outer shape/ geometry of tall buildings, while the outcome of interaction between wind aerodynamic force applied to tall buildings and their structural system is termed 'wind-induced response'.

Wind-induced response has a 'mean' component (directly linked to site-specific mean wind speed); a 'broad-band' – effectively quasi-static - component (due to excitation by

low-frequency turbulence), often referred to as 'background' component (commonly associated with the letter 'B' in codes of practice); and a 'narrow-band' component (near-resonant magnification of spectral components of loading close to any structural frequency), often associated with the letter 'R' in codes of practice.

The narrow-band component therefore dictates how 'dynamic' a structure is and is controlled by damping; for example, switching from a 2 % of critical (0.13 logarithmic decrement) to a 1 % of critical (0.06 logarithmic decrement) will increase the wind-induced acceleration by approximately 40 % and the design wind loads by approximately 30 % (assuming 50 % of this figure is governed by 'dynamics').

This statistical framework describing how the wind loading mechanism works was introduced for the first time in the 1960s by Alan Davenport^[13,14,15,16].

9.2.1 Vortex-shedding

As a result of interaction between wind and structures, alternating vortices are shed on the downstream sides of tall buildings (see Figure 9.1).

Figure 9.1
2D schematic representation of vortices generated in the wake of a cylinder.



This phenomenon, 'vortex-shedding', generates a net fluctuating force exciting the structure in the across-wind direction perpendicular to the mean wind flow. These forces are relatively small but when they occur at frequencies close to that of the structure they may be significantly amplified, particularly when damping is low.

Vortex-shedding happens at any wind speed and for any plan form, and is typically enhanced by low levels of wind turbulence (for example sea/desert exposure) and sometimes by turbulence from upwind structures. The critical vortex-shedding wind speed, at which the frequency of the shed vortices coincides with the one of the structure, can be calculated as follows:

$$V_c = \frac{n \cdot D}{St}$$

where n is the structural frequency of interest.

D is a reference dimension of the cross-section of the tall building (typically its width measured perpendicular to the direction of the mean wind speed).

St is the *Strouhal* number, a non-dimensional quantity function of the plan form of the tall building (typically ranging between 0.1, for a square, and 0.2, for a circle).

Vortex-shedding forces may have energy over a significant range of frequencies, resulting

in significant responses at wind speeds lower than the critical wind speed indicated by published *Strouhal* numbers (see Figure 9.2).

Figure 9.2
Response curve (across-wind peak dynamic base overturning moment vs. design wind speed.

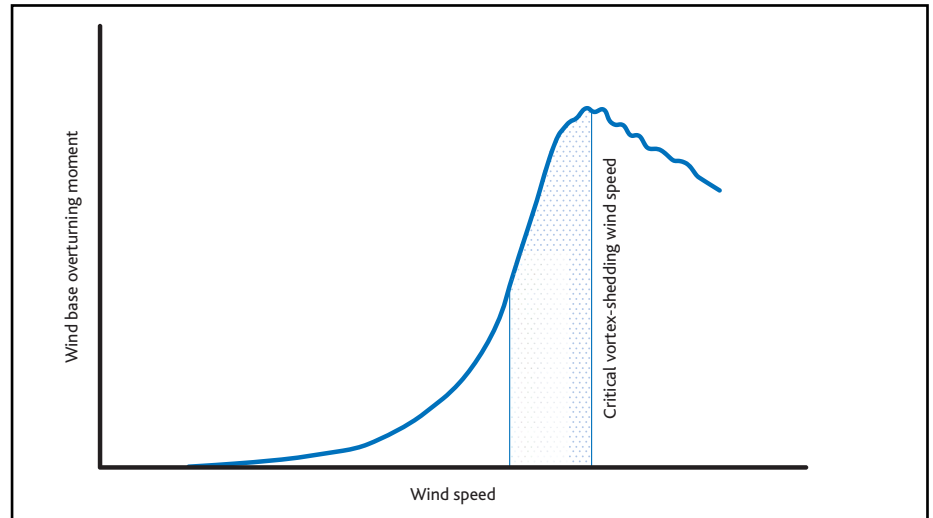

Resonant across-wind response typically causes the most critical motions felt by occupants of buildings and may govern strength design of slender buildings. Such responses are not well covered in design codes but are routinely studied in the wind tunnel.

Provided neither a vortex-shedding phenomenon nor aerodynamic interference effects caused by the close proximity with other tall buildings are 'dynamically' interacting with the structural system of buildings, more 'benign' and predictable along-wind/buffeting excitation will become the governing wind-loading mechanism for the structure.

9.2.2 Serviceability

Human response to building motion - a complex phenomenon involving many physiological and psychological factors - is generally considered as more measurable by acceleration than other quantities.

Perceptibility of wind-induced motion is inversely proportional to the square root of the product of mass, stiffness and damping^(NBCC, NRCC, 2005); therefore, to halve perceptibility, 'mass x stiffness x damping' has to be increased by a factor of four.

Criteria such as ISO 10137-2007^{(ISO, 2007)^[7]} are commonly used as benchmarks in assessing of the wind-induced performance of a tall building.

Although from a serviceability point of view drift checks under wind loading are important, wind-induced accelerations checks can in some cases be more stringent. For example, a 150m residential tall building with a first dominant cantilever mode sitting at 0.30 Hz which is experiencing under 10-year return period winds an overall building drift of 0.25m, would satisfy the most stringent codes of practice. If 10% of overall building drift is governed by 'dynamics', the resulting wind-induced peak acceleration would be 9 milli-g ($10\% \cdot 0.25 \text{ m} \cdot (2 \times \pi \times 0.30 \text{ Hz})^2 \sim 0.09 \text{ m/s}^2 \sim 9 \text{ milli-g}$); a figure well within widely accepted thresholds for

residential occupancy comfort (typically in the region of 10-15 milli-g). For more flexible and slender, tall buildings, the percentage of overall building drift governed by 'dynamics' could be as large as 50 %; the wind-induced peak acceleration would in this case be 45 milli-g, a figure exceeding any criteria for occupancy comfort.

9.2.3 Mitigation of wind loading

The resonant component of wind loading (directly linked to wind-induced accelerations experienced in a tall building) can be mitigated by:

- Increasing the stiffness of the structure - thus increasing the structural frequency.
- Increasing mass at the top of the building - requiring additional building strength to mitigate loss of structural frequency.
- Increasing the structural damping.
- Using a passive tuned-mass damper, perhaps weighing 1 % of the modal mass of the building, to increase the damping ratio to a total of 3-4 % of critical (0.19-0.25 logarithmic decrement) - active/powering systems can also be used.
- Using other viscoelastic, viscous or hydraulic damping systems to bring the total damping ratio to values of around 6-8 % of critical (0.38-0.50 logarithmic decrement).
- Changing the aerodynamics (aerodynamic measures can be either global - introduction of taper, twist, through-building openings and vented top - or local - introduction of solid or vented corner fins and slotted or chamfered corners).

A cost-benefit analysis can be run to establish, as part of the preliminary design process, the most suitable strategy to achieve specific levels of peak dynamic wind loading/wind-induced accelerations.

9.2.4 Codes of practice

While all wind codes provide guidance for assessment of the along-wind response of tall buildings (see Figure. 9.3), only a few can assist designers in predicting the strength of across-wind response - the response of the structure to the lateral-wind-turbulence component and vortex wake. These are: Australian code^{(2002)^[16]}, Canadian code^{(NBCC, 2005)^[10]}, Eurocode^{(2005)^[19]} and Japanese code^{(2004)^[20]} (the latter is, at present, the only available wind code offering guidance on assessment of the torsional response of tall buildings to wind loading excitation). It should be noted that guidance is unfortunately limited to a few simple geometries and exposures.

Figure 9.3
Schematic representation of the wind-induced response of a tall building

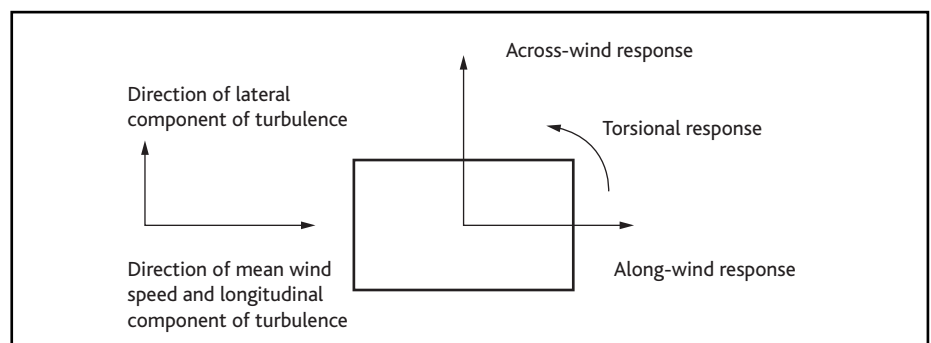

9.3 Wind-tunnel testing and wind-tunnel techniques

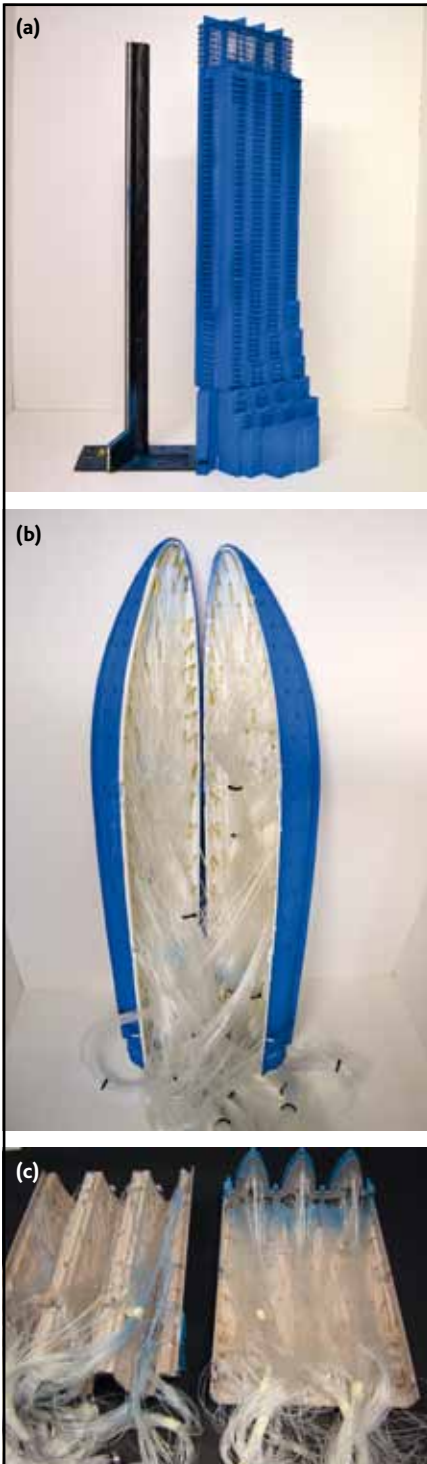

Figure 9.4

Wind tunnel models:

- (a) CRFP spine and light-weight foam component of a HFFB wind tunnel model.
- (b) inside of a wind tunnel pressure model.
- (c) inside of a wind tunnel pressure model.

When it comes to 'wind engineering' and, more specifically, wind loading on tall buildings, design codes have a relatively limited range of applicability; heights are often restricted to 200m and cross-sectional shapes are relatively orthodox; for example, square or rectangular. As a consequence, many tall buildings fall outside the intended scope of local codified wind loading requirements.

Wind tunnel tests are, therefore, often performed on such buildings to provide a detailed insight into the design forces and overall response and performance behaviour of the structure.

Wind tunnel techniques applicable for the evaluation of wind loading on tall structures are: high-frequency force balance (HFFB), simultaneous pressure integration (SPI) and aeroelastic. The first two are focused on the measurement of wind aerodynamic forces acting on tall buildings and evaluation of the wind-induced building response requires the wind tunnel data to be combined with structural properties provided by structural engineers. The aeroelastic technique is focused on directly measuring the wind-induced structural response of tall buildings.

High-frequency force balance (HFFB)

HFFB wind tunnel models must be designed for stiffness and lightness. To avoid strong contamination of the measurable signal, their lowest natural frequencies - typically in the region of 100 Hz - should be at least two times greater than expected lowest natural frequencies at full scale.

HFFB wind tunnel models are often constructed around a stiff and light central spine manufactured using materials such as carbon-fibre-reinforced polymer (CFRP) with light-foam to give the correct outer envelope of the tall building (see Figure 9.4a). There is no relationship between the inner spine of the wind tunnel model and the structural core of the real tall building.

HFFB wind tunnel models are generally mounted on stiff balances capable of simultaneously measuring time-histories of wind-base shears, wind-base overturning moments and torsion. This technique generally offers quick turnaround and a high degree of flexibility for re-analysis. As long as the outer shape of the tower does not vary, the wind tunnel data can be re-processed to reflect the evolution process of the structural arrangement of tall buildings.

As measurements at the base are effectively integrated figures, the floor-by-floor wind loading distribution along the height of the structure is estimated and not directly measured. Thus the contribution to wind loading from higher modes of vibration, often important in the design of super-tall buildings higher than 300 m, especially if tapered (Camelli, 2011)^[21] - cannot be thoroughly quantified.

Simultaneous pressure integration (SPI)

An alternative way to evaluate the wind loading acting on tall buildings and ultimately the wind-induced building response to wind loading is to simultaneously measure wind pressures over the entire building envelope and then derive the overall wind load by integration through SPI.

Similarly to the HFFB technique, SPI offers a high degree of flexibility for re-analysis at the cost of slightly longer timescales, mainly driven by the model build phase. As the measurements are simultaneous over the entire structure, the floor-by-floor wind loading distribution along the height of the building structure can be accurately assessed and contribution to wind loading from higher modes of vibration thoroughly calculated.

Wind tunnel pressure models are typically constructed using materials such as plastic, resins and fibreglass or obtained from rapid prototyping techniques such as selective laser sintering (SLS) or stereolithography (SLA). The outer envelope of the wind-tunnel model is instrumented with several hundred pressure sensors (typically 500- 800 but often exceeding 1,000 in the case of very complex façade arrangements, structurally-linked tall building complexes or super-tall buildings) measuring time-histories of local fluctuating wind pressures (see Figure 9.4b and 9.4c).

In general, and in the absence of significant proximity effects, the density of the pressure sensors (often referred to as taps) should be greater around the top third of the structure and more relaxed in its middle portion. The average density of taps should be of the order of approximately one sensor over 120 m² of building surface: this density will need to be increased (particularly over the upper portion of the tall building) should the contribution to wind loading coming from higher modes of vibration be required. Over elements where both surfaces are directly exposed to the wind such as canopies, architectural fins and high parapets pressures should be measured simultaneously on each side.

Measurements from wind tunnel pressure models can also be used to assess wind pressures to assist the design of cladding and heating, ventilation and air-conditioning systems.

Aeroelastic modelling technique

The only way to assess and evaluate wind-structure interaction is to employ the aeroelastic modelling technique. Aeroelastic wind tunnel models are designed and constructed to behave in the wind tunnel, vibrating and responding to gust wind loading excitation, exactly like the real structure.

The design of an aeroelastic wind tunnel model requires both the outer envelope of tall buildings and the internal structural arrangement to be sufficiently advanced. It needs to be constructed to accurately match the structural arrangement of the real tall building and is generally instrumented with accelerometers and/or strain gauges measuring in real time the structural response of the tall building to wind loading. The inherent structural damping ratio of the aeroelastic wind-tunnel model should be kept as low as possible (0.5 % of critical/0.03 logarithmic decrement or less).

The aeroelastic technique, like SPI, allows floor-by-floor wind-loading distribution over the height of the building, as well as the contribution to wind loading coming from higher modes of vibration, to be established. It should be noted that aeroelastic methods take longer to undertake due, primarily, to the additional time spent in the model-design/build phase and the model-calibration process.

Selecting the right wind-tunnel technique

HFFB studies are often conducted at the schematic-design (SD) stage and sometimes as early as the feasibility/concept stage, to allow detailed, shape-specific wind-induced response to be directly fed into the structural-design process.

SPI studies often follow during detailed design (DD) to refine the prediction made during SD. Aeroelastic studies are commonly used in tall building design (at DD stage) when the structural response is strongly governed by vortex-shedding approaching 'resonance' or when a direct measurement of the contribution to the total damping coming from the wind-structure interaction ('aerodynamic damping') is required.

9.4 Procuring a wind engineering consultant

The aim of this section is to help designers gather the information required by wind consultants to conduct wind-engineering studies, and ensure the outcome is sound and in line with best industry practice.

9.4.1 Atmospheric boundary layer profile simulation

The term 'atmospheric boundary layer' refers to the lowest portion of the troposphere (usually 2-3 km above the surface of the Earth) where the effects of surface roughness as well as local topography control the vertical distribution/profile of both mean wind speed and turbulence intensity (see Figure 9.5).

Figure 9.5
Schematic representation of the atmospheric boundary layer.

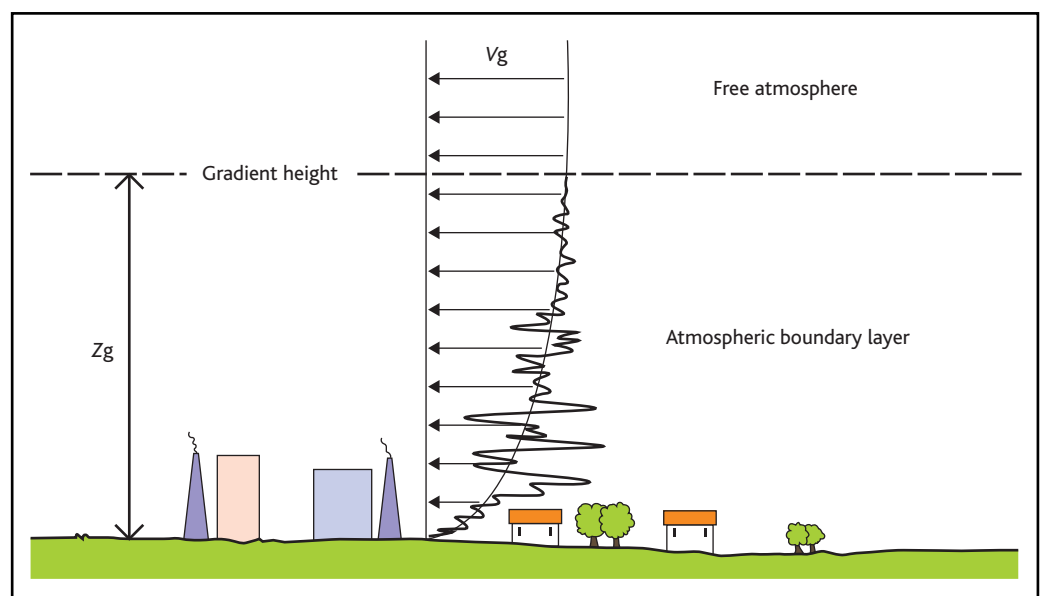

A direct comparison over the entire height of the tall building between the selected characteristic wind exposures for the project site (identified using wind models such as the one proposed by Harris and Deaves⁽¹⁹⁸¹⁾⁽²²⁾) and the mean wind speed, intensity of turbulence and appropriate gust wind speed profiles measured in the wind tunnel should be exhaustively documented by wind-engineering consultants.

Ahead of testing, the wind-tunnel laboratory should provide the design team with documentation showing that the measured mean wind speed/ turbulence intensity and turbulence length scale in the wind tunnel are respectively within 10 % and a factor of 2 from the prediction of the above theoretical model.

9.4.2 Wind-tunnel models

The geometrical scales typically employed for wind-tunnel studies ranges from 1:200 to 1:500 and the obstruction of the wind-tunnel-test section caused by the presence of the model and its surroundings should be kept to a minimum; ideally in the region of 5 % and no greater than 10 %.

The area surrounding the project site – typically to a radius of 500 m – should normally be modelled (see Figure 9.6). Significant buildings outside this area may need to be included as part of the surrounds on selected wind angles. Different surrounding scenarios, such as existing site conditions, proposed/future/consented surrounds and masterplan/project phasing, should be considered as part of the studies. Should the tall building be part of a large masterplan of which no sufficient details about the phase of construction are available investigation of the structure in an 'isolated' condition is recommended.

Figure 9.6
Wind tunnel surround model.

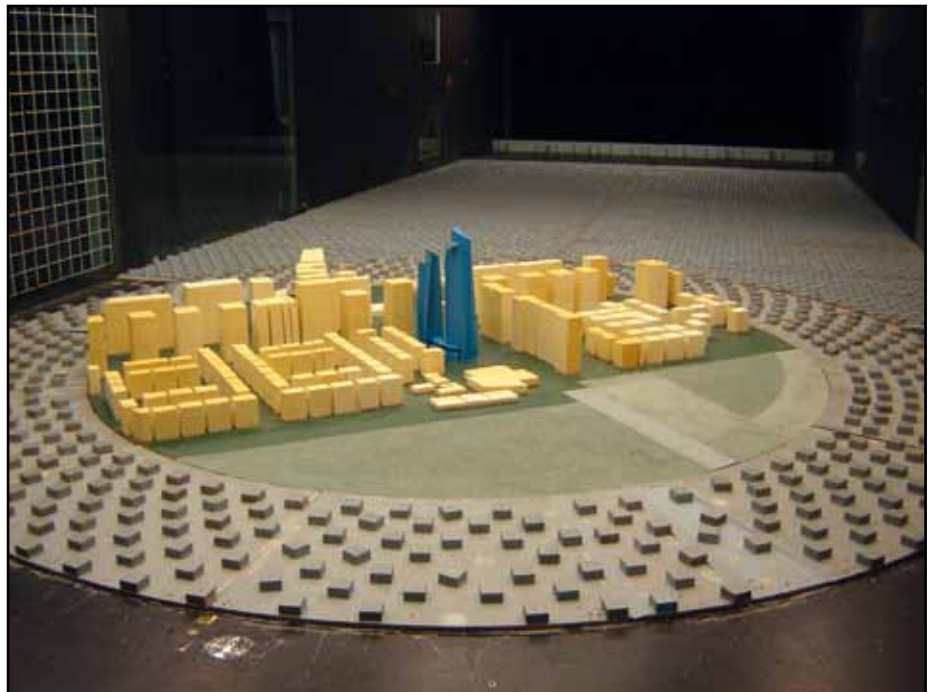

Electronic information necessary to construct surround models includes:

- Survey maps (typically .dwg/.dxf format)
- Building heights/number of storeys
- Photos from site survey (when available)
- Site plan/masterplan drawings.

To design and construct HFFB, pressure and aeroelastic models - floor plans, elevations and sections of the proposed building (typically .dwg/.dxf format) or full 3D surface models (typically 3D CAD/Rhino format) are additionally required. For aeroelastic models, a sufficiently settled set of structural properties is also necessary (see also Chapter 13).

With regard to wind-tunnel pressure models, pressure sensors designed by wind engineering consultants should be issued to designers for review and approval prior to wind tunnel testing. For aeroelastic wind-tunnel models, a direct comparison between the selected full-scale structural frequencies, mode shapes and inertial properties with those directly measured on the aeroelastic wind-tunnel model, should be exhaustively documented by wind-engineering consultants.

In general, in the design of HFFB, pressure and aeroelastic models, great care should be taken by wind-engineering consultants to minimise and control scale effects related to the geometry of the building, which could lead to results being sensitive to the wind-tunnel speed. The wind-tunnel laboratory should demonstrate that quantities such as mean aerodynamic force coefficients (drag and lift) as well as the Strouhal number are stable across a wide range of wind-tunnel speeds.

9.4.3 Wind tunnel studies

The measured frequency of HFFB, as well as the range of wind speed operated in the wind tunnel during the tests, should be documented by wind-engineering consultants.

HFFB employed by wind engineering specialists needs to provide simultaneous measurements of wind base shears, wind base over-turning moments and torsion.

The measurements for wind loading studies (HFFB, SPI or aeroelastic) should be taken around the clock at a minimum of 10° intervals. Intermediate measurements at finer intervals should be taken to capture the wind-loading peak response.

The post-processing of the measured time-histories of wind base loads (HFFB) or external wind pressures (SPI) requires information on the structural properties of the building. Provided by structural engineers, it should include mass, its in-plane eccentricity and mass moment-of-inertia distribution along the height of the tall building, structural frequencies and associated mode shapes for the fundamental and – if required – higher modes of vibration, as well as assumptions on structural damping levels to be considered.

The directional variation of wind base loads including shears, bending moments and torsion for foundations design purposes – typically calculated for 50-year-return period design wind speeds or higher – should be presented both in terms of mean, peak static (including the ‘broad-band’ component) and peak dynamic (including the ‘narrow-band’ component).

To assist the design of the super-structure, wind loads should be presented in a floor-by-floor format. The directional variation of wind-induced peak accelerations is typically calculated for 1- and 10-year-return-period design wind speeds. The results need to be compared against preferably frequency-dependent criteria such as the ISO 10137-2007 (ISO 2007) (see also Chapter 13).

When required, wind-engineering consultants, in agreement with designers, can provide a range of sensitivities analyses to cover uncertainties of structural parameters such as natural frequencies, structural damping and inertial properties.

When HFFB, SPI and aeroelastic studies are performed on tall buildings, direct comparison between the different techniques should be provided by wind-engineering consultants.

For additional information on the subject of wind-tunnel testing, please refer to ASCE Manual of Practice No.67 for Wind Tunnel Studies (ASCE 1998)^[23] and the AWES-QAM-1-2001 Quality Assurance Manual (AWES, 2001)^[24].

Table 9.1 shows indicative budget fees and timescales for wind-engineering studies on a typical single-tower tall-building project.

Table 9.1
Procurement cost and timescales.

Note
1. Prices refer to the year of publication of the present document.

Type of study	Indicative budget fees ¹ in USD	Timescales in weeks
Wind microclimate	15-20k	2-3
Wind loading	20-25k	3-4
Cladding pressure	20-30k	3-4
Aeroelastic	50k+	5-6

9.4.4 Computational fluid dynamics

Computational fluid dynamics (CFD) is used in engineering applications such as aeronautics and investigation of internal flows but external flows around buildings in complex urban environments are far from being streamlined and are dominated by separation phenomena.

The correct mathematical modelling of turbulence driving the dynamic response of a given structure of this type of flow regime is still subject to debate among the research community, even for fairly simple geometrical configurations. It is likely to remain

impractical to model turbulence at all the length-scales necessary to model separated wind-flow behaviour reliably for some decades.

Although in some cases apparently good results may be achieved, in others it is clear that they have not. Large eddy-simulation-modelling developments have more potential than other CFD methods at present but require more computing power than is typically available on a commercial basis.

The use of CFD is not recommended without full-scale or model-scale validation of key results.

Wind-tunnel testing does not suffer from the above-mentioned drawbacks and is a practical (with time-scale advantages) and well-proven approach for which the methodology has reached consensus among both the scientific and engineering community.

10. Seismic engineering

Seismic engineering encompasses the concept, analysis, design and detailing of structures, structural elements and non-structural building elements to withstand seismic events of varying intensity and frequency.

Characteristics of a tall building that make its response to seismic movements unique include:

- A fundamental, translational period of vibration significantly in excess of two seconds.
- Significant mass participation and lateral response in higher modes of vibration.
- A seismic-force-resistance system with a slender aspect ratio such that significant portions of the lateral drift are due to the axial deformation of the walls and/or columns as compared to shearing deformation of the frames and walls.

Traditional codes which use an elastic response analysis with force reduction factor R are not suitable for the seismic design of high-rise buildings. They do not deal with the non-linear behaviour of tall buildings, whereby several modes of vibration contribute significantly to the seismic response of the structure.

The aim of this chapter is to provide guidance for designers of tall buildings in seismically active regions.

10.1 Risk and code derivation

Allowance for potential intensity of seismic events used in building design is determined from a statistical assessment of historical data and accepted levels of risk.

These statistical results are used to produce tables and maps of design ground accelerations, known as seismic hazard maps, for use in seismic analysis. In the case of tall buildings, it is usual to carry out specific risk/hazard analysis, including the characterisation of specific seismic input, such as accelerograms and seismic displacements which come from different sources.

For each separate, associated event-return period, there is a correspondingly different expectation for the performance of the structure and this forms the basis of a performance-based design approach appropriate to tall buildings.

Eurocode 8 (EC8), as well as the Council on Tall Buildings and Urban Habitat (CTBUH) ^[1] in its *Recommendations for the Seismic Design of High-rise Buildings*, promote such an approach with their requirement to meet two or more separate performance criteria.

10.1.1 Performance-based design

Performance-based design is the preferred approach to seismic engineering in modern codes. For tall buildings in particular, two or more different levels of response should be explicitly considered.

EC8 establishes two fundamental requirements: damage limitation whereby the structure shall withstand seismic action with a larger probability of occurrence (a 95-year return earthquake) without damage and the associated limitation of use, and a no-collapse event whereby the structure has to retain its integrity and a residual bearing capacity after an extreme seismic event (a 475-year return earthquake).

In the CTBUH guidance document *Recommendations for the Seismic Design of High-rise*, three levels of ground motion are considered, with different expectations:

- For frequent earthquakes (a 95-year return earthquake) the building should suffer little or no damage. Its capacity for resisting gravity loads and future events must remain intact. The building and its structural members must remain within their elastic range.
- For rare earthquakes (a 475-year return earthquake as used in several standard seismic design codes), normal buildings may not be repairable but will retain their capacity to support gravity loads and some capacity for resisting further lateral loading, while important buildings are still expected to remain principally within the elastic range.
- For very rare earthquakes (a 2475-year return earthquake), an ordinary building will suffer heavy, unreparable damage and its capacity to resist further lateral loading will be spent. It will, however, retain its capacity to resist the real/expected gravity load, enabling evacuation of the building. More important buildings should retain some capacity for resisting further lateral loads.

Both the EC8 and CTBUH approaches entail precise definition of the deformation limits and related level of damages expected for each level of performance.

Limit values are usually established in advanced codes and, in some cases, are a matter of agreement between client and designer.

10.1.2 Local effects of ground conditions

The stratum encountered at a specific project site has a major impact on the level of seismic ground acceleration to which a building is subjected. Typically, a weaker stratum beneath a building amplifies the intensity of ground acceleration at the surface.

Longer-period (low-frequency) components of a seismic event are, typically, amplified in weaker soils due to resonance with the natural period of the soil. This is of particular concern to tall buildings with typically longer natural periods (low fundamental frequencies).

Other issues related to soil conditions at a particular site include landslides, consolidation of loose soil resulting in total and differential settlements, and liquefaction. Depending upon the expected peak ground acceleration of a site and the characteristics of the

underlying strata, site-specific seismic-hazard assessments may be warranted. Such assessments will investigate the soil characteristics at the site above rock head and the location of known seismic faults that could have an impact on the subject site.

Liquefaction involves the consolidation of loose soils, in which the settlement occurs in a very short time, causing a sudden increase in pore-water pressure. As a result, effective stresses are reduced to zero and the soil effectively turns to liquid, with subsequent loss of bearing capacity. Poorly-graded soils and reclaimed land are most at risk of liquefaction and, in such cases, it is common to use deep foundations, which allow for the transmission of vertical forces to strata without problems of liquefaction.

10.2 Seismic action

Seismic design of tall buildings requires characterisation of at least two levels of shaking: service level earthquakes to check the damage requirements and maximum considered earthquakes to ensure non-collapse of structures.

In general, seismic hazards are described in codes in terms of a single parameter, namely, the value of the reference peak ground acceleration related to a specific type of ground and to the zone in which the structure is located.

When more specific evaluation of seismic action is considered, specific seismic-hazard analysis may be carried out to determine the amplitude of those earthquake levels. Probabilistic seismic-hazard analysis should be used. In places located closer to active faults (less than 10km) capable of producing earthquakes of magnitudes in excess of M6, deterministic seismic hazard analysis should also be used for maximum considered earthquakes (see, for example, ASCE 7).

10.2.1 Elastic response spectrum

Seismic action is represented in basic form by the earthquake motion at a given point in an elastic ground-acceleration response-spectrum.

Frequently the shape of the elastic response spectrum is taken as being the same for the two levels of seismic action, the no-collapse and damage limitation requirements.

Figure 10.1
 Typical shape of the elastic response spectrum EC8.

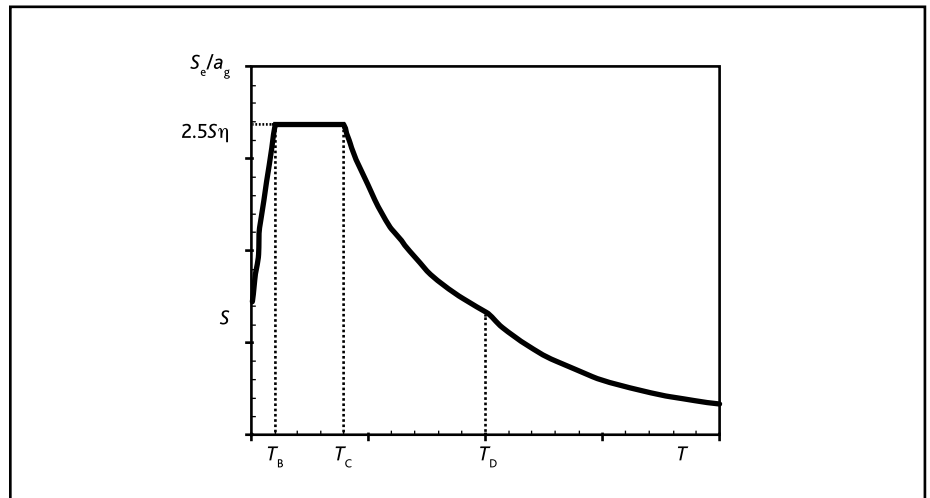

It is important to note that the spectra provided by the code are usually related to a viscous damping of 5 %. In the case of tall buildings, this value is very high and the spectrum has to be amplified accordingly. For example, in EC8 the damping correction factor η may be determined by the expression:

$$\eta = \sqrt{10/(5+\xi)} \geq 0.55$$

Where ξ is the viscous damping ratio of the structure expressed as a percentage. Therefore, for a tall building with an expected value $\xi = 2.5$, the amplification factor of the spectrum should be 1.15.

The typical shape of the spectrum in codes has two descend parts (see Figure 10.1):

- For $T_c \leq T \leq T_D$ the acceleration is proportional to $1/T$
- For $T \geq T_D$ the acceleration is proportional to $1/T^2$

For example in EC8, dependent on soil type, the values of T_c (end of the plateau) vary from 0.4 to 1.0 (limit between the $1/T$ and $1/T^2$ acceleration zone), the value of $T_D = 2.0$ s.

As the first mode in tall buildings is normally greater than 2.0 s, the principal mode of vibration of a tall building is usually in the $1/T^2$ acceleration curve zone.

Code spectra are usually calculated from recorded earthquakes with non-long periods. Therefore, the direct use of standard spectrum has to be carefully calibrated. EC8, for example, includes specific response spectrum for structures of long vibration periods such as tall buildings. Figure 10.2 shows the elastic displacement-response spectrum to be used for analysis of structures in which T_E varies from 4.5 to 6.0 s depending on the type of soil and $T_F = 10$ s. Elastic acceleration spectrum can be derived directly from the displacement spectrum.

Figure 10.2
Elastic displacement-response spectrum
for long periods (EC8).

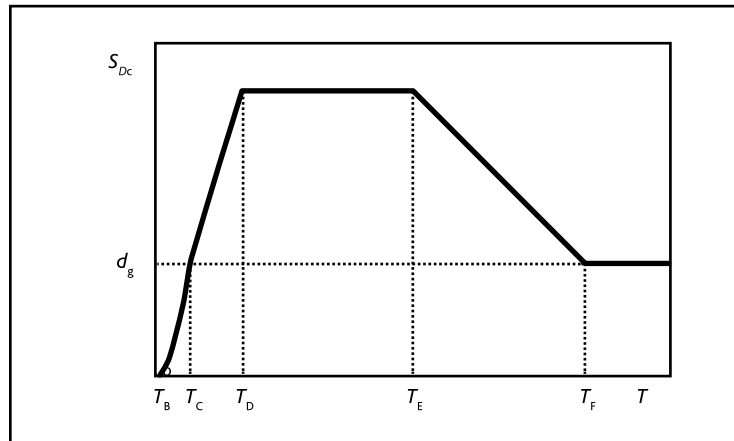

It is important to know that when increasing the magnitude over the predominant period, the spectrum shifts to higher values. The same phenomenon can be seen when the distance from the epicentre increases and when the ground is softer (Kalkan and Chopra 2010). Consequently, tall buildings are more sensitive to long-distance high-magnitude earthquakes, particularly when the ground is soft.

10.2.2 Time – history representation

Seismic motion can also be represented in terms of ground acceleration time-histories and related quantities: velocity and displacements.

Depending on the nature of the application and information available, modelling of seismic motion can be created using artificial accelerograms and recorded or simulated accelerograms. In the case of artificial accelerograms, duration should be consistent with magnitude and other relevant features of the seismic event. Selection and modification of accelerograms for dynamic analyses is a crucial task to be carried out by experts in seismic engineering. EC8 and, more specifically, TBI in its *Guidelines for Performance-Based Seismic Design of Tall Buildings* include guidelines for this process.

10.3 Conceptual seismic design of tall buildings

10.3.1 System configurations

For all structures, and tall buildings in particular, architectural decisions have an enormous impact on security and performance during a seismic attack.

In seismic zones, it is highly recommended to configure buildings and their resistance systems in a clear and simple way. Arrangement of the structural elements should be planned with regularity and clear load paths so as to avoid uncertainty and complex analysis. Geometries and configurations with complicated behaviour should therefore be avoided.

These include:

- Large changes in building stiffness
- Large changes in building mass
- Repositioning of bracing elements from floor to floor
- Interaction of two or more towers with a common base
- Significant column transfer or offsets
- Gravity-induced horizontal shear forces caused by system eccentricities
- Limited connectivity of bracing elements to floor diaphragms.

It is not always possible to avoid the aforementioned configurations. Nevertheless, avoiding their use will allow for a greater degree of confidence in predicting structural behaviour. In general, as the structural system becomes more complex, uncertainty in predicting its response is higher.

As a design tool for architects and engineers, FEMA 454 chapter 5 covers possible strategies to combine architectural expression and proper seismic behaviour.

10.3.2 Structural performance hierarchy

The first step in seismic design should be to identify zones or elements where non-linear response is anticipated. For frame or braced-frame structures, yielding well distributed over the height is preferable to yielding concentrated in one of a few storeys. Core wall structures target yielding at wall opening coupling beams, over the full height of the building, and yielding of the walls at their base.

Another aim of preliminary design is to target yielding to occur in components reliably capable of ductile response. Desirable modes of inelastic response include:

- Flexural yielding in reinforced concrete beams, slabs, shear walls' bases and conventionally-reinforced coupling beams with relatively slender proportions
- Yielding of diagonal reinforcement in diagonally-reinforced concrete coupling beams
- Yielding in tension steel elements such as steel braces
- Yielding in ductile fuses or energy dissipation devices.

10.3.3 Seismic dynamic behaviour of tall buildings

Wind load is normally the governing action in tall buildings even in seismic areas. In zones with moderate earthquakes, a building designed to behave properly in relation to wind effects requires only small but vital adjustments to have an adequate response to seismic action.

Even in highly-seismic areas, it is quite possible for wind demands to exceed Service Level Earthquakes or, for some elements, even Maximum Considered Earthquakes shaking demands. In addition, wind over-turning moments may exceed seismic over-turning moments when defining the lower-bound strength of the structural system. Therefore, wind performance should be evaluated in parallel with seismic analysis.

One of the specific characteristics of seismic behaviour in tall buildings is the heavy influence of higher dynamic modes of vibration. Traditional engineering practice for non-tall buildings has focused strictly on the first translational mode when setting strength requirements. For tall buildings, the second or even third mode of vibration can be equally, if not more, important to the overall design.

As illustrated in Figure 10.3, the influence of these higher modes of vibration can result in significantly higher flexural, as well as shear, demands well above the base of the building.

Figure 10.3
Seismic elastic response of 135m high-tall building with a central core

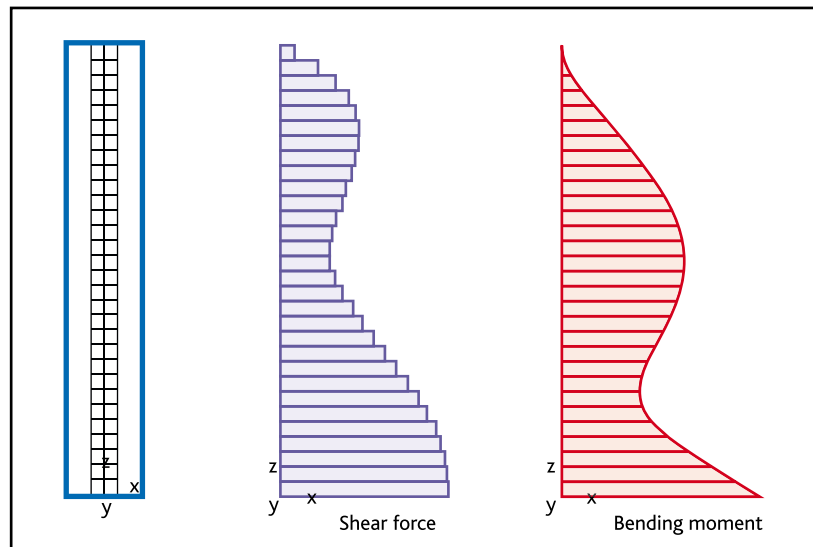

10.4 Seismic analysis

Different types of analysis can be used for different design levels and requirements. 3D models are essential to capture translational as well as torsional effects.

Elastic analysis and linear response-history analysis are appropriate for service assessment, as component responses are smaller than those causing yielding.

Nonlinear response-history analysis is required for non-collapse (ultimate state) performance evaluation. The objective of this evaluation is implicitly achieved by using this analysis to demonstrate that, under the maximum considered earthquake, collapse does not occur while forces and deformations are within acceptable limits.

Therefore, the basic tools for designing are elastic response spectra for the service earthquake, and non-linear response-history analysis for non-collapse (ultimate state) performance evaluation. Non-linear analyses require knowledge of the reinforcement in the non-elastic zone; therefore, the seismic analysis for non-collapse situations is normally conducted in two phases:

Phase 1: Response spectrum analysis takes into account, in a simplified way, the non-linear behaviour of the structure using a response modification coefficient. With the results of this analysis, reinforcement of the structure is calculated.

Phase 2: Non-linear analysis uses the reinforcement previously defined. With this analysis, the performance criteria of the building is checked.

10.4.1 Modelling

The mathematical model of the structure should represent the spatial distribution of mass and stiffness. Linear models should always be the first approach to understanding the dynamic behaviour of buildings under seismic actions.

Linear structural models should incorporate realistic estimates of stiffness which consider the anticipated level of damage. The expected parameters, as opposed to nominal properties, should be used when computing modulus of elasticity. For reinforced concrete elements, most international codes provide guidelines on appropriate stiffness modifiers for cracked stiffness values.

Usually, codes include two set of values: one for the damage limitation stage (service earthquake) and wind, and the other for the ultimate limit state (or maximum credible earthquake). LATBSDC, for example, gives the values included in Table 10.1 for expected material strengths and estimates of component stiffness respectively.

Table 10.1
Reinforced concrete component stiffness values (2011 LATBSDC)

Element	Serviceability –Damage limitation level	No-Collapse Earthquake Nonlinear Model
Structural walls	Flexural – $0.9 I_g$ Shear – $1.0 A_g$	Flexural – * Shear – $1.0 A_g$
Basement walls	Flexural – $1.0 I_g$ Shear – $1.0 A_g$	Flexural – $0.8 I_g$ Shear – $0.8 A_g$
Coupling beams	Flexural – $0.5 I_g$ Shear – $1.0 A_g$	Flexural – $0.2 I_g$ Shear – $1.0 A_g$
Diaphragm(in-plane-only)	Flexural – $0.5 I_g$ Shear – $0.8 A_g$	Flexural – $0.25 I_g$ Shear – $0.25 A_g$
Moment frame beams	Flexural – $0.7 I_g$ Shear – $1.0 A_g$	Flexural – $0.35 I_g$ Shear – $1.0 A_g$
Moment frame columns	Flexural – $0.9 I_g$ Shear – $1.0 A_g$	Flexural – $0.7 I_g$ Shear – $1.0 A_g$

Note
* Nonlinear fibre elements automatically account for cracking of concrete due to the concrete zero-tension stiffness

Where:

- I_g represents the gross value of the moment of inertia
- A_g the gross value of the concrete area

Mathematical models should address torsional effects, including inherent eccentricities resulting from the distribution of mass and stiffness.

Modelling of joints in moment-resistance frames should accurately account for stiffness of the joint, including the panel zone.

Floor diaphragms should be included in the model using realistic stiffness. Explicit modelling of diaphragms at locations where significant force transfer occurs is necessary. Common assumptions of perfect rigidity will not generally provide accurate estimates of transfer forces.

Analytical models of the structure should incorporate the entire building, including the subterranean floors, columns and walls. The model should include the mass and mass moment of the inertia of those elements.

Tall buildings are complex dynamic systems. An important goal is to identify all regions of potential inelastic behaviour, whether or not they have been targeted in preliminary design as zones of desired inelastic behaviour. A typical example of 'non-target zones' of inelastic behaviour is flexural yielding of walls in middle or upper floors, often caused by higher mode effects.

Another example is the flexural yielding of columns in middle or upper levels of moment frames, even though columns are made to be more resistant to flexure than beams. All such areas involving an expectation of non-linear behaviour should be detailed for ductility.

All structural elements for which significant strength degradation could occur should be modelled to take potential deterioration into account.

Damping is a measure of a building's natural ability to dissipate energy through a range of mechanisms including:

- Internal friction at structural joints
- Friction between structure and architectural fixtures and fittings
- Local yielding of structural elements as the building flexes when subjected to dynamic loading.

In simple terms, the level of damping in a building is its ability to decay the amplitude of vibration oscillations over time.

Typical damping values quoted for reinforced concrete buildings when subjected to ultimate seismic events are in the order of 5 % of critical damping; encompassing energy absorption due to plastic hinging and actual available damping of the structure in its elastic range. Values to be used in analysis will depend on the type of analysis performed. For example, for a non-linear time-history analysis, the energy absorption component is explicitly calculated and an allowance is made separately for the building's intrinsic damping, usually around 2.5 %.

10.4.2 Response-spectrum modal analysis

Elastic response-spectrum analysis is appropriate if the demand on each structural component is less than its nominal strength and will generally be valid for the damage limitation state: service level assessment.

When using a response-spectrum modal analysis, the spectrum has to be modified to consider a realistic value of the expected damping. Furthermore, a sufficient number of modes must be included, capturing 95 % of the total mass in each axis.

The complete quadratic combination (CQC) method should be used to combine modal responses to represent the overall response of the structure considering all significant modes. The effects of multi-directional loading should be considered according to the applicable code.

In normal buildings and in bridges, it is usual to use a reduction factor R to indirectly take into account non-linear behaviour for non-collapse situations. As noted previously, this approach is not appropriate for evaluation of the non-linear response of tall buildings as the ductility associated with the fundamental mode is typically applied to all modes in the analysis. In reality, however, the structural response is not the same and, indeed, the same ductility may not be available in all modes. Nevertheless, it is normal to use modified response spectra to predesign the reinforcement prior to carrying out non-linear time history analysis of the structure.

10.4.3 Time-history linear analysis

In time-history analysis, a recorded or artificial earthquake is used as the input function for a full dynamic analysis of the structure and the response of all modes of vibration to this time-varying input is recorded. As the response is time-dependent, the true interaction of the individual modes of vibration is taken into account.

Due to the individual characteristics of different earthquake events, several input time-histories are required to assess the structure's response to as broad a range of events as can be expected.

It is highly recommended to carry out a linear time-history analysis before performing a non-linear time-history analysis, calibrating the elastic results and comparing them with the elastic response spectra results.

10.4.4 Non-linear response time-history analysis

Nonlinear response-history analysis should be used for evaluations involving significant nonlinear response in structural elements, and therefore is the ideal tool for non-collapse earthquake evaluation. Non-linear analysis should include second order effects, taking into account all vertical loads (permanent plus a fraction of live loads) present in seismic events.

Non-linear time-history analysis is performed to capture the post-yield behaviour of the structure, using selected ground motion records. In the model, post-linear behaviour of the elements contributing to the lateral stiffness has to be included. It is common to use a generalised force-deformation curve to model the behaviour of moment frame members.

Figure 10.4
 Typical generalised force-deformation relations for concrete elements of components and concentrated non-linear zones.

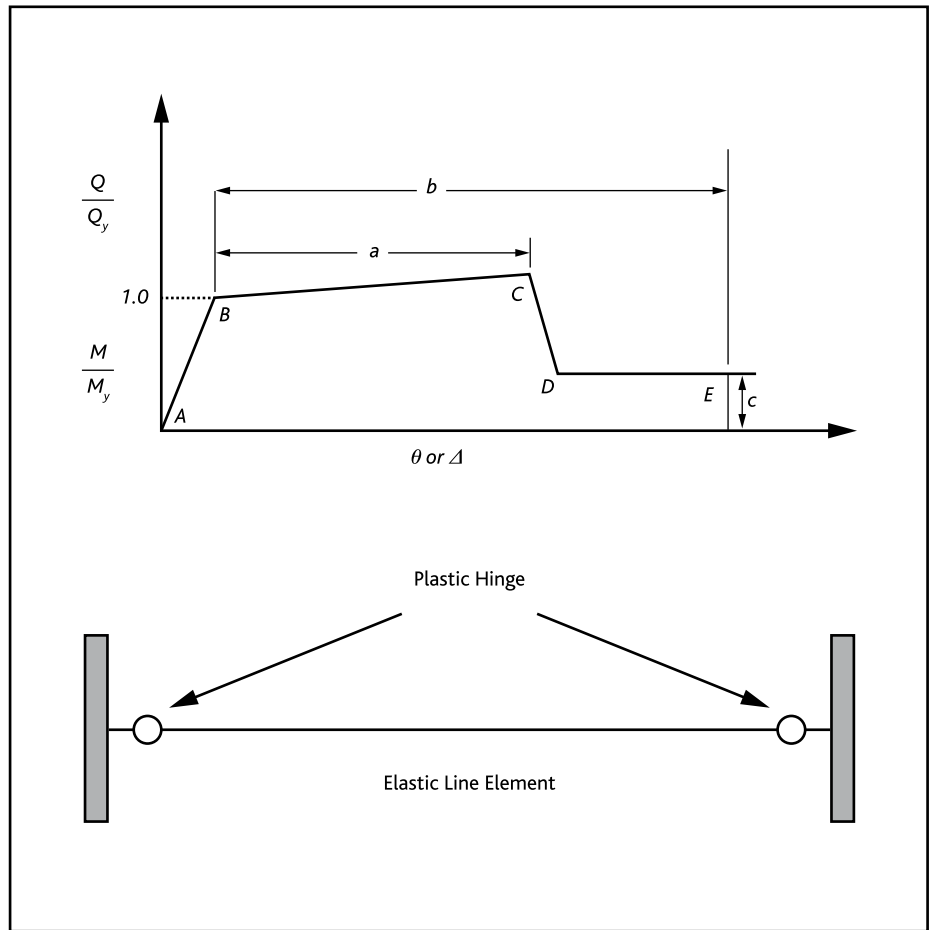

For beams, it can reflect localised plasticity by assigning a moment plastic hinge at each end. Plastic rotation angles depend on: the reinforcement ratio, transversal reinforcement amount and disposition, and level of shear force. In the case of columns, the plastic rotation angles also depend on the level of axial forces. ASCE 41 – 06 gives values for the plastic rotations, together with acceptance criteria taking into account required performance level.

For modelling walls and cores, fibre elements (wall slices as discrete 2D axial members with uniform non-linearity throughout their length) are commonly used.

Figure 10.5
 Plan view of a wall defined with fibre elements.

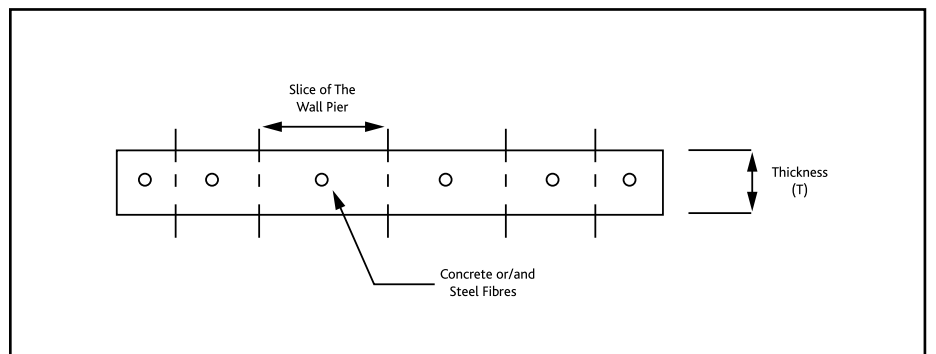

To take into account the effect of transverse reinforcement in the behaviour of confined concrete, a Mander model is normally used. The Mander model defines the relationship stress-strain in the non-confined and confined concrete; in the latter case, the model includes strength hardening and the increase of the strain limits due to transverse reinforcement.

10.4.5 Non-linear static analysis

Non-linear static procedures (pushover analysis) may be useful as a design aid but should not be relied upon to quantify response for tall buildings. Nevertheless, there is much intrinsic value to a non-linear static analysis in the visualisation of the progression of inelastic behaviour and assist in identifying the primary modes of inelastic behaviour response. Also, a sufficient number of modes must be included, capturing 90 % of the total mass in each horizontal direction.

10.4.6 Soil-foundation structure interaction

From a seismic point of view, the principal impact of soil-foundation effects are:

- The soil foundation system will have some mass and flexibility affecting the natural periods and mode shapes of the whole structure.
- Structural vibration energy can be transmitted to the ground and dissipated by the soil (material damping) and by radiation energy (radiation damping). As radiation damping is normally low for foundation rocking over long periods, it is normally ignored for tall buildings.
- The stiffness and embedment of the foundations affect seismic movements transmitted to the building. As the seismic waves do not arrive at all points of the foundations at the same time, there is a reduction in the action for shorter wavelengths (shorter periods).

Due to uncertainties in defining soil parameters, a study of the sensitivity using upper and lower bond values should be undertaken to investigate seismic behaviour.

10.4.7 Target displacements and rotations

Performance objectives and the fulfilment of the acceptance criteria should be assessed in all critical elements of the structure and in the overall structural system.

ASCE 41-06 is the most widely-used document featuring performance levels and tabulating acceptance criteria for structural components. In addition, PEER (2010) provides fundamental information for establishing performance objectives and modelling approaches.

10.5 Design

As noted previously, due to the relatively rare nature of extreme design seismic events, an acceptance of significant damage and inelastic design behaviour is expected.

This philosophy has its basis in permitting the controlled formation of plastic hinges in appropriate structural members to enable the building to continue to drift laterally through rotation of the hinges, without additional flexure or shear being induced.

Due to the ductile nature of flexural yielding - the preferred plastic hinge mechanism - great care should be taken to avoid yielding in shear, due to its brittle nature. Once the preferred ductile mechanisms are selected, designed and detailed accordingly the remaining structural elements can be designed elastically for the reduced forces.

Systems/elements either specific or pertinent to tall buildings include core and walls; outriggers; braced frames and diagrids; transfer structures; and podium/basement structures.

10.5.1 Core and walls

Core and walls are normally the principal horizontal resistance system in many tall buildings. Some non-linear response of these elements is expected.

A requisite in the design of ductile structural walls and cores is that flexural yielding in clearly defined plastic zones should control the strength, inelastic deformation, and energy dissipation in the structure. Brittle failure mechanism or those with limited ductility should not be permitted. The principal source of energy dissipation in the core wall must be the yielding of the flexural reinforcement in the plastic hinge regions; normally, but not exclusively, at the base of the wall. Flexure yielding of coupling beams also provides energy absorption.

Failure modes to be prevented are those due to diagonal compression caused by shear, instability of thin-walled sections or of the principal compression reinforcement, sliding shear along construction joints, and shear or bond failure along lapped splices or anchorages.

If the shear is the governing effect, the behaviour of such a wall in response to reversed cyclic loadings is characterised by a steady reduction of strength and ability to dissipate energy. However, walls designed for flexural ductility and protected against a shear failure exhibit a greatly improved response. It should be noted that shear forces at the base of a building calculated by non-linear response history analysis may significantly exceed those calculated by a linear response spectrum analysis.

For more detail information about core and shear wall dynamic behaviour, see Paulay and Priestley (1992) and Whyte and Stojadinovic (PEER 2013).

10.5.2 Outrigger systems

Outrigger systems are often used as part of the lateral force-resisting system of tall buildings and are typically composed of either deep concrete beams/walls, or concrete or steel trusses connecting a central core to the perimeter structural system. For outrigger elements, there is a high shear and/or compression/tension demand which offers little opportunity for flexural yielding, leading to obvious concerns of brittle failure of the outriggers. Available ductility is not reliable or consistent and such building types require detailed, specific analysis to establish the ductile behaviour of such elements.

One issue arising when outriggers are used is variation of the compression-tension transferred to outer columns when the real performance of the outrigger is far from the elastic behaviour.

Figure 10.6
Uncertainty in the axial forces in the outer columns in case of non-linear behaviour of the outrigger.

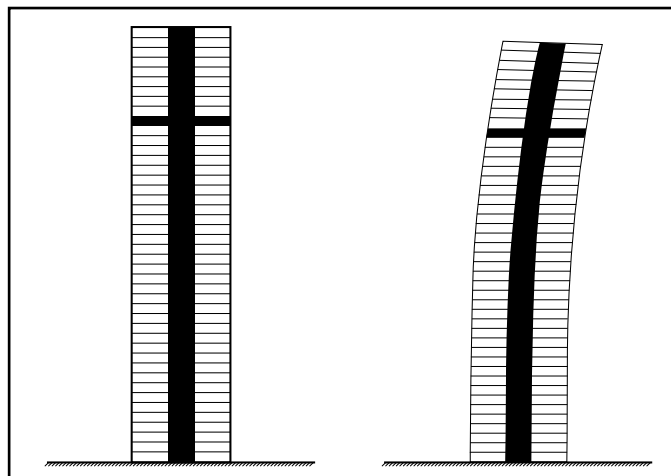

10.5.3 Diagrid systems

Diagrid systems, similar to outriggers, act predominantly in axial compression and tension. Any seismic energy dissipation occurs predominantly through flexure and postbuckling/tension-yielding behaviour of the diagonal members. When the lateral and gravity load are taken by the same elements, limited ductility is available without compromising the gravity support. Unlike outriggers, diagrid systems typically have redundant load paths, making them more efficient than outrigger systems in withstanding seismic actions. Such systems require specific analysis to verify their non-linear behaviour.

Figure 10.7
Diagrid systems.

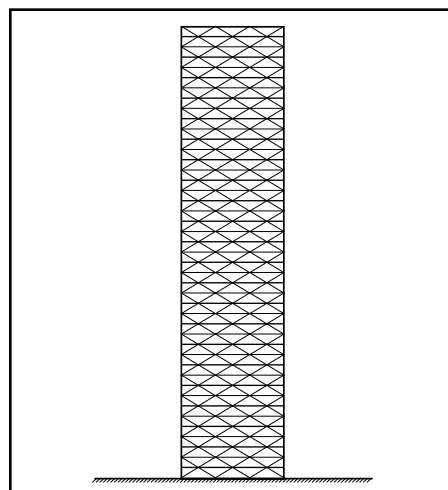

10.5.4 Braced frames

Braced frames are classified as either concentrically braced or eccentrically braced, referring to whether the bracing elements connect directly to one another at joints.

Figure 10.8
Concentrically-braced system.

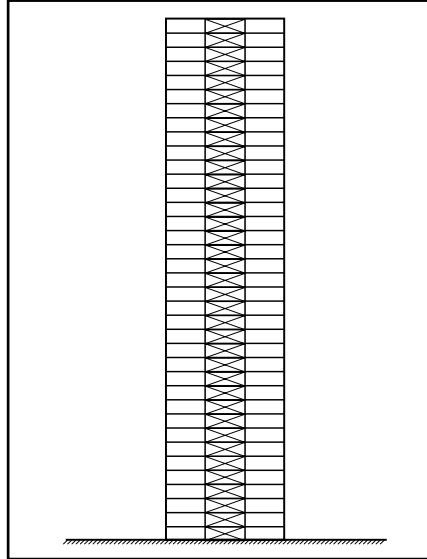

Concentrically-braced frames have limited ductility due to their primarily axial behaviour, while eccentric braces introduce local bending moments. By that eccentricity, advantage is taken of short ductile sections between the ends of bracing members. Those ends provide significant ductility, enabling the bracing elements to remain elastic while significant inelastic yielding of the ductile 'fuse' occurs.

Figure 10.9
Eccentric-braced system.

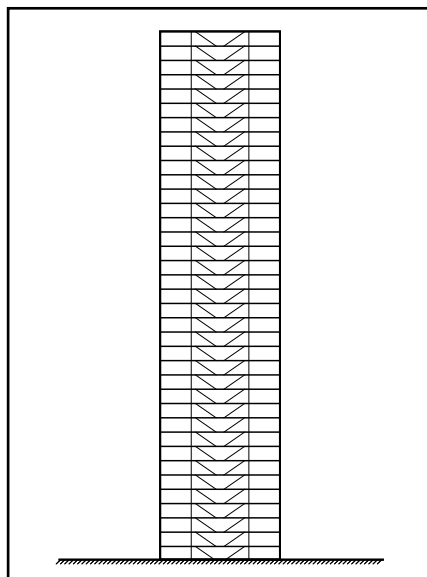

10.5.5 Transfer structures

Transfer structures are typically elements subjected to high shear demand under gravity load; their failure could lead to a disproportionate collapse of the supported structure. These elements should be designed to ensure that their vertical load-carrying capacity is maintained under the expected seismic deformation, and should not participate in the lateral load resistance of the structure. Therefore, its seismic behaviour should basically be in the elastic range.

Figure 10.10
Transfer structures.

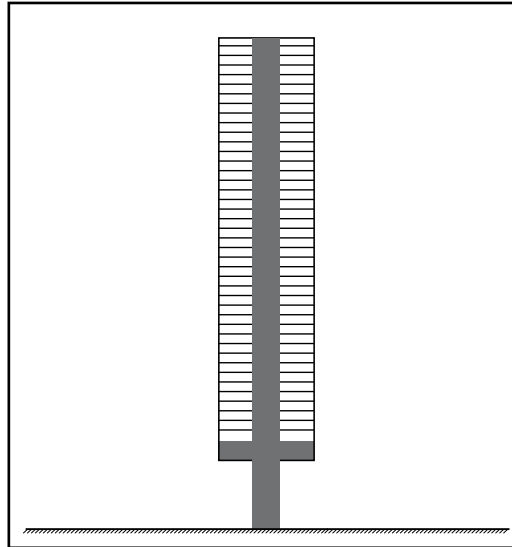

10.5.6 Podium and basement

Podium and basement structures are typically characterised by their large inherent stiffness. This sudden increase in stiffness near the base of the structure can induce very significant prying forces on the principal lateral load-resisting system of tall buildings, leading to large shear reversals at the interface which can greatly increase the design forces.

Floor diaphragms may need to be increased in strength to take these additional forces and shears into account.

Figure 10.11
Podium and basements effects.

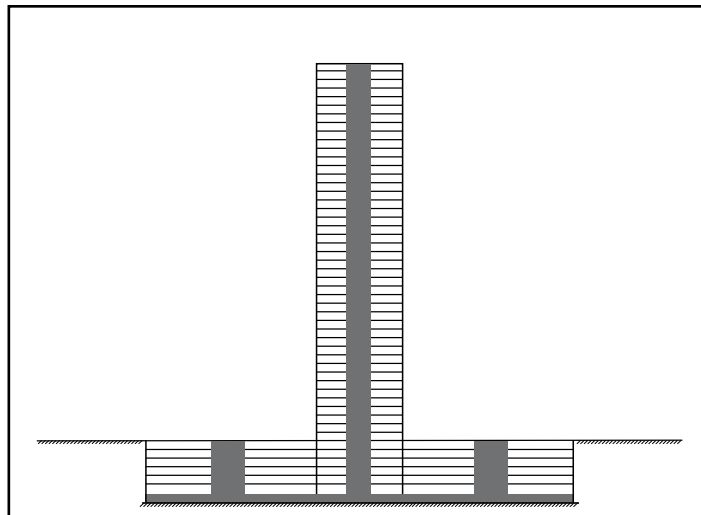

Joining two tall buildings with a common podium structure may also generate significant loads in the podium, if the buildings move out of phase.

Podium and basement structures also increase the stiffness of the building, leading to lower fundamental periods and subsequently higher base shears. Basements are usually large enough that the forces in the basement walls are in the elastic range. It is usually unnecessary, and also not desirable, to isolate the tower from the basement unless the basement is shallow. In such cases consideration may need to be given to isolating the tower structures through the basement/podium levels.

10.5.7 Floor slabs

The primary role of floor plates is to act as horizontal diaphragms to transfer the horizontal component of seismic force from each floor to the lateral load-resisting structural system. As they typically have very little ductility, design forces for diaphragms are higher than those corresponding to the lateral force-resisting system. They must be strong enough to resist force transmitted by the lateral load-resisting system, if the 'as-constructed' strength of the system turns out to be greater than the calculated strength. This is typically accounted for in codes of practice by using an 'over-strength' factor.

Due to its inherently high in-plane strength, the design of the floor itself under these loads is seldom critical and connection to the lateral force-resisting system becomes the primary consideration. Care should be taken, however, when large openings are present in the slab. The use of flat slabs as part of a lateral load-resisting system should be carefully considered and avoided where possible, due to the shear dominant nature of flat slabs.

10.5.8 Other structural elements

For elements not considered part of the lateral force-resisting system, seismic forces are not taken into account in their design and their stiffness should not be considered in the seismic analysis. However, to ensure stability and compatibility, they must be designed and/or detailed to transfer and withstand gravity forces under expected lateral drifts known as drift compatibility.

10.5.9 Architectural elements

Architectural elements, such as partitions and cladding, should be appropriately detailed, considering the large deflections resulting from an earthquake-induced motion. A particular example is the correct detailing of a separation joint between internal block partitions abutting columns and slabs. If a structural member is artificially stiffened by such partitions or by cladding built against it, additional load not built into its design or detailing can be attracted to the element and local failure could occur.

10.5.10 Seismic dampers

Additional damping is provided to reduce the effects of dynamic amplification. Seismic damping systems include fluid viscous dampers, visco-elastic dampers, friction braces and un-bonded braces, allowing a controlled release of energy.

For modelling, if there is significant variability in the properties of those devices, a sensitivity analysis incorporating upper and lower boundaries of those characteristics should be undertaken.

When the device has a functional displacement limit beyond which the element will lose its properties, it is highly recommended that the structure be checked to ensure it is acceptable at a value of 50 % of this limit.

10.6 Detailing

Carefully considered structural detailing is a vital part of seismic engineering, to ensure the structure has the ability to deform inelastically.

Careful detailing of reinforcement laps and anchorage is required to ensure the reinforcement can reach its ultimate yield strength.

Structural elements, in addition to the requirement to yield plastically, also need to be capable of multiple cycles of loading without fracture which requires additional detailing considerations. The codes usually include provisions to increase the anchorage and lap lengths.

10.6.1 Beams

Beams are typically expected to be the source of most rotational hinge mechanisms in structures and careful detailing is required to ensure that mechanisms develop flexurally without inducing shear failure.

Where beams have low span-to-depth ratios, as is typical in the coupling beams of core wall lateral load-resisting systems often used in tall buildings, their behaviour is dictated primarily by shear rather than flexure.

The 'shear' is transferred through a diagonal strut under high compression and associated perpendicular tension; with the higher modes of vibration associated with tall buildings, significant numbers of flexural reversals are possible in a seismic event, placing even more demand on these members. To prevent brittle failure of these elements, diagonally-reinforced struts are often detailed to develop the shear strength required and enable significant ductility.

Figure 10.12
Diagonally-reinforced deep coupling.

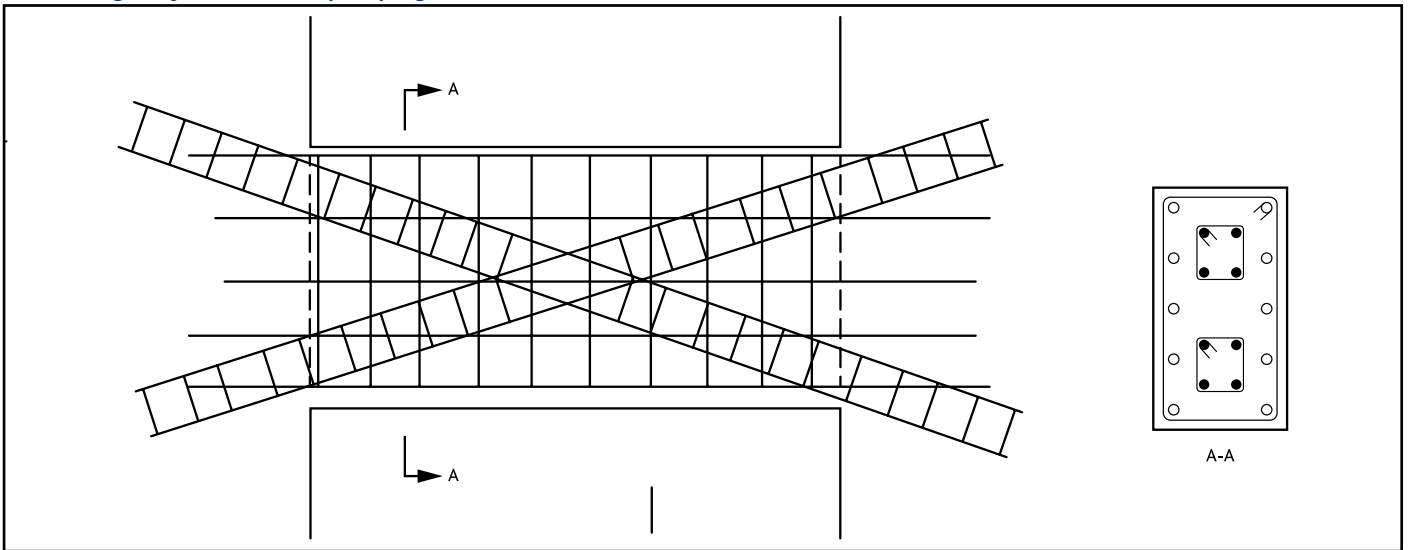

10.6.2 Columns

Under large inelastic drifts, significant forces are induced in the columns requiring effective confinement for two reasons:

- To ensure the required strength is developed, following potential spalling of the cover concrete under large load reversals.
- To ensure the levels of strain required for ductile behaviour are reached.

In the case of using high-strength concrete being used in non-elastic zones, higher levels of confinement are required to achieve adequate ductility and strength.

To ensure adequate confinement is provided, vertical and transverse reinforcement needs to be detailed to provide restraint to the concrete core. Reducing the spacing of vertical bars around the section perimeter is of benefit and a reduction in the spacing of the transverse reinforcement is also particularly important in confining the core, while assisting in the prevention of buckling of the compression reinforcement.

Spiral or closed circular hoops are more efficient than square or rectangular closed loops, as they provide uniform restraint around the perimeter rather than just at the corners by setting up hoop stresses. For square or rectangular ties, equivalent, effective restraint is only provided through the introduction of additional cross ties.

10.6.3 Walls

In regions of low to moderate seismicity, plastic hinges are detailed to develop primarily in beam members, and this mechanism is typically sufficient.

For high seismic zones, energy dissipation due to ductility of beams alone is, usually, not sufficient and some additional ductility is required from the walls to ensure an efficient structural solution. Significant load reversals are also expected in high seismic zones and can lead to major problems if special detailing is not provided. The problem is exacerbated for shear due to the degradation of the concrete interfaces, particularly where net

tension is possible at the extremities, leaving reinforcement as the only mechanism to resist shear. Under these conditions, diagonal bars are often used to resist the 'shear' in tension in each direction.

For high compression zones at the ends of walls under flexure, high levels of confinement of the concrete are required for reasons similar to those discussed earlier for columns. These zones, which typically become thicker and may resist all of the flexural forces in the wall, are known as boundary elements.

10.6.4 Slab-column connection details

Proper slab-column detailing is a basic requirement to ensure the integrity of the structure during major earthquakes. Slab-column connections are subjected to lateral deformations, resulting in an increase of moment and shear demands. These demands may result in yielding of slab reinforcement. Even more critical is the increased shear demand; therefore, detailing for preventing punching shear failure is crucial.

10.6.5 Slab-wall connection details

In buildings supported partially or totally by walls or cores, the integrity of the slab-wall connections plays a vital role in the behaviour of the structure. As the core sways due to seismic action, an important rotation is imposed on the connection between slabs and walls. The rotations are increased by vertical motions associated with elongation and shortening of the core wall over its height as a result of the flexural action. For more information on detailing, see Klemencic (2006).

10.6.6 Collector details

In tall buildings, it is common to see transmission of horizontal forces, between the central core and other walls at the top level of the podium.

In these cases, collector slab details are essential to ensure the transmission of forces across the different elements. Special precautions have to be taken when shear forces are combined with tensile axial forces due to the substantial reduction caused by the tensile force in the shear resistance of concrete.

11. Time-dependent behaviour

In addition to tolerances in construction, a structural element can deviate from its theoretical dimensions and position because of movements after the element is constructed. Although this deviation is common to all structures, movements in tall buildings require specific consideration because of the natural action of gravity and eccentric loading occurring as a result of the building size and shape.

The movement of the building occurs in both the vertical direction (axial shortening) and the horizontal direction (deviation from verticality) due to cumulative loading, time-dependent material properties (such as creep and shrinkage) and the construction sequence. This movement is very important in the design and construction of tall buildings as it informs many structural and non-structural considerations.

Movements in tall buildings and related problems, if identified near the end of the structural design process and prior to construction, can lead to solutions that are both ineffective and difficult to implement during the construction process. The problems associated with building movements are best addressed in the design stage, based on the results of a staged construction analysis.

This chapter provides information on expected building movements and variations in internal forces resulting from sequential construction and time-dependent material properties. The information contained within is intended to provide assistance in the design of the structure, to give details of the interface with follow-on trade construction, and to identify tolerance and movement data which should be compiled for future reference by users of the building. Refer also to Chapters 2 and 8 in relation to building drift and dynamic behaviour.

11.1 Definitions

Axial shortening

The axial shortening of a building is the vertical displacement of the building resulting from the sum of the axial deformations of the vertical members at each floor. In reinforced concrete vertical members (columns and/or walls), the initial axial deformation resulting from applied load (elastic deformation) is compounded by additional deformation due to creep and shrinkage of the concrete, which is usually greater in magnitude than the elastic deformation.

Concrete columns in tall buildings may undergo elastic deformation estimated to be more than 100 mm for a building height of 200 m (equivalent to 500 micro-strains or 2 mm/story in the case of a typical office building). These values might be doubled over time by additional creep- and shrinkage-induced shortening.

Differential axial shortening arises because of the differences in the axial stresses between columns and the core walls. The core walls of tall buildings are generally quite large, and their size is influenced not only by axial stress requirements but also by stiffness requirements to resist lateral loads.

The cross sections of columns are usually designed to be as small as possible so columns are generally more heavily stressed than core walls. As construction progresses, columns and core walls undergo different amounts and rates of elastic, creep, and shrinkage shortening. After completion of the building, creep and shrinkage shortening continue to develop differently in core walls and columns throughout the service life of the building. In addition, differential shortening between adjacent columns is significant when their locations and corresponding stress levels are different, eg, among interior, exterior, and corner columns.

Differential shortening between core walls and columns is generally greatest at between two-thirds and three-quarters of the height of a tall building, but not at the top of the building, as the shortening is based on SUBTO movement (see Figure 11.1 and Section 11.1.4).

Figure 11.1
Example of differential shortening between
core walls and columns in a tall building.
 Image: Daewoo Engineering and Construction.

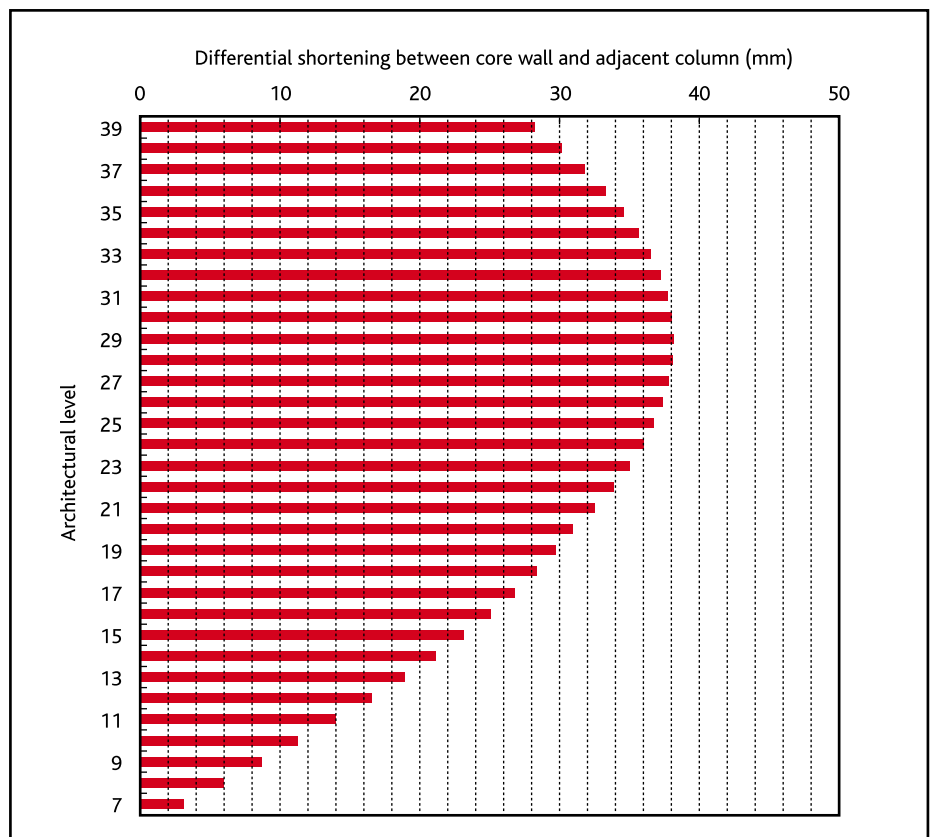

The following factors are known to have an effect on axial shortening and should, therefore, be considered in the calculation of the shortening:

- Properties of the concrete (initial and time-dependent properties)
 - Compressive strength
 - Nominal initial modulus of elasticity
 - Creep
 - Shrinkage.

- Design assumptions for columns and walls
 - Cross-sectional area
 - Longitudinal reinforcement ratio
 - Area of embedded steel section (for composite members)
 - Volume-to-surface ratio (effective thickness).
- Loading assumptions
 - Construction sequence
 - Progress of occupancy
 - Environmental conditions (relative humidity).

11.1.2 Deviation from verticality

When a tall building has an eccentric or irregular plan or a large variation in shape vertically, it could be subject to a considerable amount of differential shortening, which in turn may cause permanent leaning of the building or a deviation from verticality in the construction stage and after occupancy.

Additionally, tall buildings with symmetric plans may deviate from verticality due to an asymmetric construction sequence. As a deviation from verticality is the extreme case of differential axial shortening, it has more significant adverse effects on tall buildings and, therefore, should be identified before construction so that proper countermeasures can be taken.

The major factors affecting deviation from verticality are similar to those affecting axial shortening.

11.1.3 Target time

Because the building movement develops with time, it is necessary to define a 'target time'; the point in time for which the movement is estimated. The movement is the result of the combined effects of accumulated loading, creep and shrinkage during construction and the residual effect of creep and shrinkage after occupancy.

Therefore, the ultimate target time is usually some time after completion of construction. Based on the creep and shrinkage properties of the concrete, the target time could be at least three years after completion of construction, when more than 90 % of the creep and shrinkage expected to develop during the service life has already occurred. A different target time could be chosen to identify the building movement at a specific time, such as at the installation of lifts.

11.1.4 UPTO and SUBTO movement

Building movement is the sum of the deformations of all of the building elements after they have been constructed. As the elements are constructed consecutively, generally floor-by-floor, the total building movement can be classified as the movement occurring prior to the completed construction of a certain floor (UPTO) or subsequent to completion of construction of that floor (SUBTO).

UPTO movement at a specific floor refers to movement already developed or accumulated in the time from the start of building construction to completion of the floor under consideration. This movement is negligible if a building is constructed so that every floor conforms to its designed location at the time of construction. With regard to axial shortening, it is standard construction practice that every floor be made level and, hence, the UPTO differential shortening is always zero.

SUBTO movement at a specific floor refers to movement developed or accumulated at a target time subsequent to when the floor under consideration was constructed. It is usually greatest at between two-thirds and three-quarters of the height of a tall building, and gradually decreases above that height due to the lower weight of the remaining floors above and the shorter remaining construction time. SUBTO movement is more important than UPTO movement as it causes the differential movement of adjoining or adjacent building elements; thereby producing additional (locked-in) forces on structural members and adverse effects on non-structural elements, such as façades and lifts.

11.2 Adverse effects

11.2.1 Slabs – forces and deflections

Differential shortening of vertical structural elements will cause an associated movement in the floor slabs, which may cause cracking and a redistribution of internal forces. This problem is most likely to occur between the central core walls (where applicable) and the perimeter columns, inducing deflections in the floor framing between these vertical elements.

As the central core generally has lower stresses than the perimeter columns and may be constructed in advance using climbing forms, the shortening of the core and SUBTO shortening, in particular, is significantly less than that of perimeter columns.

The effect of differential shortening on a floor slab in terms of internal forces is a progressive alteration of the distribution of bending moments and shear forces in the structural elements of the slab due to the additional locked-in forces that develop over time. This redistribution must be recognised in the design of the floor structures and the horizontal members must be reinforced accordingly.

Furthermore, the differential settling of supports can affect the levelness of the floors and, if not carefully considered or compensated for in the design and construction, this unevenness may give rise to tolerance problems for floor finishes and cladding details.

11 Time-dependent behaviour

11.2.2 Beams/outriggers/ belt trusses – locked-in forces

On the upper floors of a building cumulative differential shortening between vertical members can cause adjacent (deep) beams to tilt, resulting in locked-in (moment and shear) forces.

These forces can be a significant design problem if certain lateral stability systems such as outriggers and/or belt trusses engage these vertical members, as the lateral stability systems are designed to have greater stiffness than other structural members. In extreme cases, the total member forces, including the locked-in forces, might exceed the capacity of the member; a problem that can be solved only through design changes or alternative construction processes (see Section 11.4).

In addition, the redistribution of internal forces in horizontal members in turn applies counter-forces on vertical members and this may become a concern when there are significant variations over time. These variations should be estimated in the analysis and their effect on safety must be properly considered.

11.2.3 Dimensional incompatibility

Movement in tall buildings may give rise to construction and serviceability problems as a result of dimensional incompatibilities between the building structure and non-structural elements.

With regard to axial shortening, the shortened vertical structure can transfer compressive forces to neighbouring non-structural elements such as partitions, cladding, piping and lift guide rails not designed to support vertical loads (see Figure 11.2). A slab that tilts because of differential shortening or deviation from verticality may cause cracking or bowing of partitions, unless joints sufficiently allowing for partition movement are provided.

Deviations from verticality mostly influence lifts because verticality is the main concern during installation and maintenance. The overall deflection of a tall building during construction will cause the lift shaft to deflect in the same direction and thus reduce the vertical space available for the installation of lifts.

Occasionally it becomes necessary to remove part of the core wall if a distortion of the lift shaft occurs during the installation of the lifts. If a deviation from verticality occurs after installation of the lifts, other problems such as degradation in performance or durability may arise. In a building with excessive deviation from verticality, the lifts will come into contact with deflected guide rails, reducing the lifts' maximum speed and causing premature wear in their mechanical components such as clips and rollers.

The effect of a dimensional incompatibility is usually greater in upper floors due to the accumulated differential movement between structural and non-structural elements. However, occasionally incompatibility is greatest at the bottom of the building, where both elastic and time-dependent stresses increase significantly over the construction period.

Figure 11.2
Bond failure between sealant and slab (upper) and scrape in lift guide rail (lower) due to downward movement of the building structure (90 mm) relative to non-structural elements (Bast *et al.* 2003)^[25].



Details for attaching non-structural elements to the structure must be planned so their displacement or deformation relative to the structure will not cause stresses. All tall building movements and deformations should be understood and considered in conjunction with other members of the design team to ensure adequate detailing provision and to avoid adverse effects on the building services and architecture.

11.3 Prediction and verification

11.3.1 Movement analysis

One-column shortening analysis

Axial shortening of a tall building can be predicted relatively easily during the preliminary design stage. The prediction is used to evaluate the approximate effect of axial shortening and to guide the design of the structure. Axial shortening is the sum of elastic, creep and shrinkage deformations, and depends on the construction sequence (Fintel *et al.* 1986)^[27].

A one-column shortening analysis can be performed using repetitive spreadsheet calculations with quantities such as member geometries obtained from drawings, material properties from code provisions, applied loads on each member from the calculation of tributary areas, environmental conditions from meteorological records, and stages of construction from construction schedules.

This analysis method has been widely used for decades, but over recent years there has been a move towards construction stage analysis and time-history analysis of a 3D model. As single column analysis is of connected structural members it cannot consider restraining effects against differential shortening of the beams or slabs connected to the column or wall. When these restraining effects are significant it becomes necessary to conduct additional structural analyses based on the tentative results from a one-column shortening analysis. Construction-stage analysis and time-history analysis of a 3D model provide a more direct method of accounting for these effects.

Construction-stage analysis

A construction-stage analysis, followed by a time-history analysis using a 3D model and covering the service life of the building, gives more accurate and comprehensive results than a one-column shortening analysis for building movements. Construction-stage and time-history analyses consider the effects of sequences of gravity loading and consecutive changes in the structural system as construction progresses. These methods additionally evaluate the effects of the various time-dependent properties of the concrete elements of the structure on the building structural response (ie, movements, variations in internal forces, moments and stress distributions, and development of locked-in forces).

A construction-stage analysis must be followed by time-history analysis to further investigate changes over time of the structural response of the building to sustained gravity loading following completion, as influenced by creep and shrinkage in concrete structural elements. The analysis is performed for a target time and the specified service life. Proper attention should be given to the influence that cracking of sections may have on the results of these analyses.

Building movements in horizontal and vertical directions can be predicted at any stage of construction. Post-processing of the analysis results is simpler than one-column analysis, and results can be directly represented using a graphical user interface (see Figure 11.3). Locked-in forces due to movement in horizontal members, such as transfer beams, outriggers, and belt walls/trusses, are calculated and the effects on other non-structural elements can be assessed by resolving the components of the movement.

Although construction-stage analysis is performed for a designated target time, the analysis can be used to predict variations in building movements and internal forces as construction progresses for comparison with the data from field measurements and surveys (Ha *et al.* 2011)^[28]. The results of construction stage analysis are updated based on these comparisons, as frequently as required. Field monitoring and building-response-model updating can continue following the end of construction, through comparisons with the results of time-history analysis to obtain better predictions of the structural response over time.

Construction-stage analysis can be combined with an analysis of soil-structure interactions to identify the effects of changes in the boundary conditions. In fact, the sequential nature of this analysis can incorporate soil-structure interactions which include the effects of differential settling of the foundation on the response of the building structure.

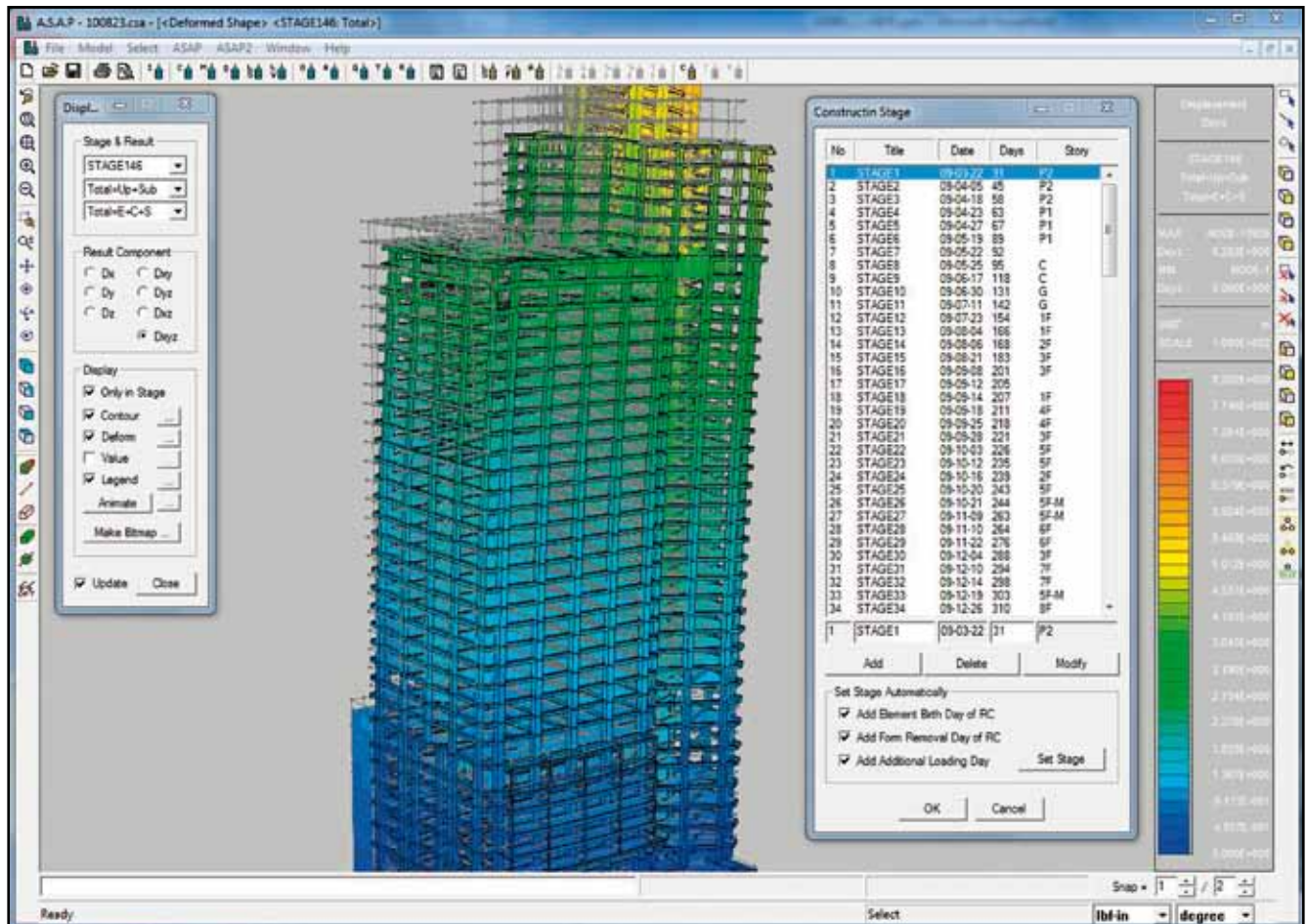

Figure 11.3

Example of a graphical representation of the results of construction stage analysis (Ha *et al.* 2011)^[28].

To evaluate the structural response of complex and sensitive structures such as high-rise buildings over time, including creep and shrinkage effects, the most general approach incorporates the time-dependent constitutive relations for concrete into numerical methods for continuum mechanics or for structures composed of beams (typically finite element methods).

With regard to creep, it must be noted that creep-prediction models used in the current design recommendations and technical guides mentioned in section 11.3.2 are based on the assumption that the linear viscoelastic behaviour of concrete varies with age, combining the assumptions of linearity and superposition of the strain responses for stresses applied sequentially. This model leads to a hereditary, integral formulation for the creep constitutive law and, consequently, to a system of either linear Volterra integral compatibility equations or equilibrium equations in which the force method or the deformation method, respectively, are used for the structural analysis.

A general and effective procedure is to obtain the incremental form of the integral-type creep constitutive law for a small time-step first. Detailed instructions for this procedure can be found in section 7.2.4 of the *fib* (Fédération internationale du béton or International Federation for Structural Concrete) Model Code for Concrete Structures 2010 (*fib* 2013)^[29],

in the *fib* textbook *Structural Concrete* (Chiorino & Sassone 2010)^[30], and in a more extended form in the ACI (American Concrete Institute) guide ACI 209.3R (ACI Committee 209 2011)^[31].

There are a number of commercial structural-analysis software programs known to have construction-stage and time-history analysis features. Most of these programs were originally developed for bridges, for which these analyses are essential in the design and construction stages.

11.3.2 Material testing for creep and shrinkage

The time-dependent properties of concrete, such as stress-induced (initial plus creep) strains and shrinkage strains used in the analysis of structural movement, are mostly based on prediction models suggested by design codes and recommendations, technical guides and specialised literature (ACI Committee 209 2005, 2008 and 2011^[31, 32, 33, 34], Bažant & Baweja 2000^[35, 36, 37], *fib* 2013^[29], Gardner 2004^[38]). Although the range of applicability of recent models has been progressively extended to include types of concrete with higher mean compressive strengths - reaching 120 MPa for the creep prediction model of *fib* Model Code 2010 (*fib* 2013^[29]) - some of the models may prove to be inadequate for the prediction of time-dependent properties of high-strength or high-performance concrete.

Designers must additionally be aware of a persistent problem with model uncertainties, particularly in creep prediction. This uncertainty is reflected in the significant differences that exist among the most widely used prediction models, both in the long-term predicted values of the creep strains and in their behaviour over time. There is currently no consensus on an approach for resolving these discrepancies (Chiorino & Carreira 2013^[37]; ACI Committee 209 2008 and 2011^[31, 32, 33]).

Notwithstanding any action taken to reduce the creep and shrinkage properties of the specific type of concrete being used, all efforts should be undertaken to reduce the degree of model uncertainty in the prediction of the time-dependent strains. Reductions can be achieved using convenient strategies for calibrating the significant parameters in the models to the specific characteristics of the concrete mixture to be used in the construction.

The two most efficient options are the following:

1. A Bayesian statistical approach, which improves the prediction using existing data on similar types of concrete in the same region.
2. The use of short-term tests of one to three months duration on the given type of concrete and the fitting of curves with the least-squares method (Bažant & Baweja, 2000^[35]; Bažant *et al.*, 2009^[38]) (see Figure 11.4).

Although the tests can be conducted on specimens taken from the actual concrete poured on the site, it is better to establish a systematic testing campaign much earlier in the process, following completed development of the concrete mix. Updated prediction models for the time-dependent properties of the concrete can then be used in movement analysis to increase its accuracy.

Figure 11.4
Measuring creep strain from concrete
specimens in a climate chamber.

Photo: Daewoo Engineering and Construction.



11.3.3 Field monitoring

During the construction phase, a tall building is monitored to record actual movement for comparison with predicted movement. To measure the long-term effects of concrete creep and shrinkage, the duration of monitoring can be extended to the target time. In cases where preset (ie compensation) is applied during construction, the effect of the preset could be monitored. If the actual movement differs from predictions, the target and the amount of preset could be adjusted, based on the results of monitoring.

Two types of monitoring can be used for measuring the actual building movement during construction. Sensor-based measurements of the deformations and displacements of individual members involve field testing of materials, with full-size specimens and embedded reinforcing steel under sequential loading in varying environmental conditions. The other type is surveying the 'as-built' condition of a building to identify the movement by measuring chronological changes in three-dimensional locations of designated points on the building.

However, this approach is generally not feasible, considering the total number of columns and walls and the long period of measurement. Usually, only certain columns and walls on a specific floor are selected for monitoring. The preferred floors to be measured are the lowest ones, where the shortening from all of the subsequent load applications can be recorded from the beginning to the end of construction. Additional floors can be chosen when there is an abrupt change in the building plan or the structural materials, for example, reinforced concrete to steel.

To monitor variations in the actual shortening values, the compressive strains of the columns and the core walls are measured with vibrating-wire strain gauges. For reinforced concrete structures, these gauges can be embedded in the member before

11 Time-dependent behaviour

casting the concrete (see Figure 11.5) or attached to the surface of the member after the forms are removed. If strain gauges can be installed in every column from the basement to the roof, then the total shortening of the building can be obtained by summing the measurements for each floor.

Figure 11.5
Vibrating-wire strain gauges.



The measured strains are periodically compared with predicted strains from a movement analysis (see Figure 11.6). The analysis must have updated input data for material properties and a construction sequence as realistic as possible, to give accurate predictions of the strains. When a real-time monitoring system is implemented to compare the actual strain and/or stress levels against the analysis results, back-analysis and modification of the building design is possible in the event that the actual measurements deviate from the targets (McCafferty *et al.* 2011^[39]).

In addition to vibrating-wire strain gauges, other sensors can be used independently or in combination to measure different types of movement. For example, Linear Variable Differential Transducers (LVDT) can be used for displacement, level meters for levelness, tilt meters for rotation and load cells for pressure.

The measurements may be taken manually with a portable data logger, or the gauges and the logger may be part of an automatic measurement system. The initial measurement of the strain is taken before pouring the concrete, followed by periodic measurements, for example four times a day, after the concrete is poured and subsequently reduced to a single measurement each week. When an automatic measurement system is employed, the data logger can be configured to vary the periods between measurements. State-of-the-art data loggers can be accessed through a wireless network module that sends the measured data to the construction site office or any other location.

Figure 11.6
Comparison of measured and predicted axial strains for a steel-reinforced concrete column in a tall building during construction.

Graph: Daewoo Engineering and Construction.

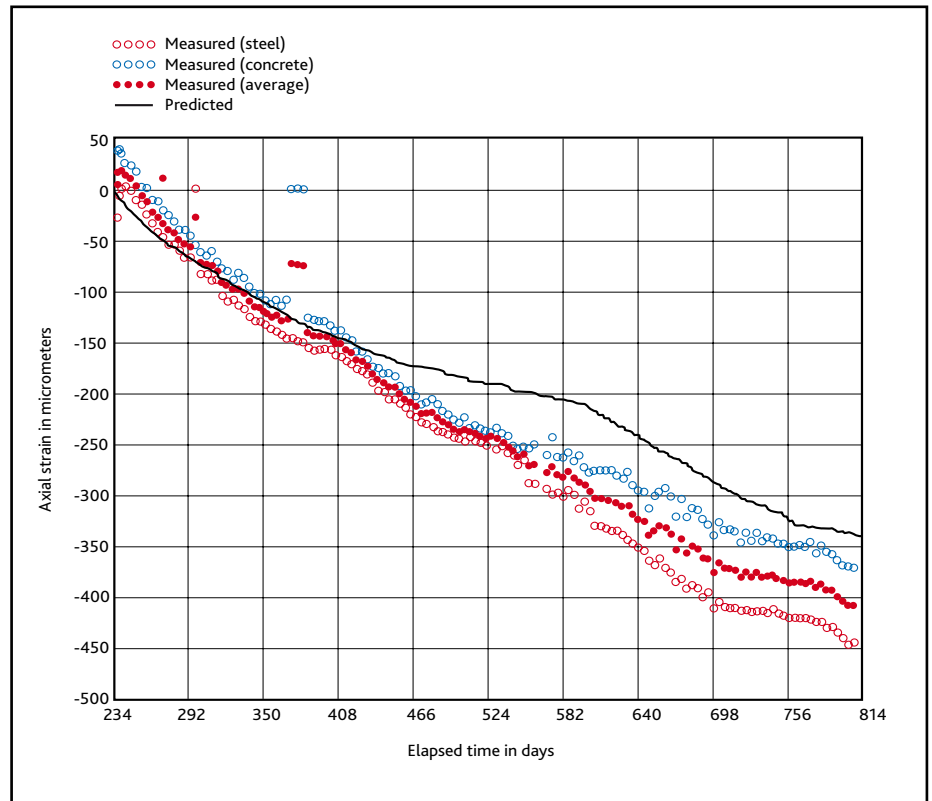

While measurements are taken only from selected structural members and the movements of other members are assumed, the survey is for the entire building as it is being constructed. The survey is usually performed optically by professional surveyors at specific intervals of construction, for example, every 10th floor, and changes in selected locations are recorded until the completion of the building.

Considering allowable tolerances of construction at every floor and latent survey errors, survey results may not accurately reflect building movement but the results represent the general tendency of the movement. Therefore, it is not necessary to perform the survey when the construction of each floor is finished.

Currently cutting-edge technologies such as 3D laser scanning (see Figure 11.7) and satellite-based measurement systems are being introduced to enhance survey accuracy and overcome human errors in conventional survey methods.

Figure 11.7
Scanned point-cloud image of the lift shafts
of a tall building generated by a
3-dimensional laser scanner.

Image: Daewoo Engineering and Construction.

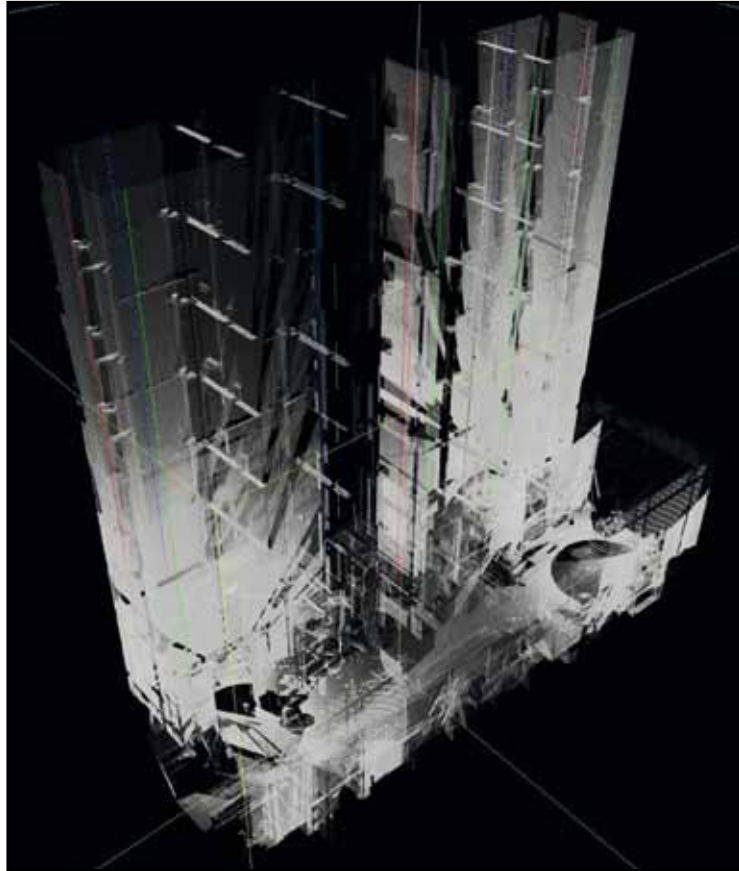

11.4 Corrective measures

Corrective measures for the effects of building movements can be taken at either the design or construction stage but it is preferable to identify and resolve problems at the design stage. For corrective measures taken during construction, the focus should be on how to solve the problem, not just on how to compensate for the movement (Ha *et al.* 2011^[28]).

Most of the adverse effects stated in section 11.2 can be solved by adjusting the design or materials to have smaller or equal movements, setting up the joints to respond to differential movement or making non-structural elements absorb structural movement. A preset of the structure can be used during the construction process, with due caution. Considerations at the design and construction stages, and the recommended method for preset in the construction stage, are dealt with in Section 11.4.1 below.

11.4.1 Design considerations

Consideration should be given to likely movement during the design phase to determine the suitability of the proposed structural system and member proportions. To minimise the effects of building movement, individual members must behave or deform (shorten) with similar magnitudes and rates. This behaviour can be determined in the preliminary analysis. Appropriate materials can then be selected and procured, and the design of the structure modified to accommodate movement (Carreira & Poulos 2007^[40]).

Optimisation of plan and member geometry

The effects of differential elastic shortening can be reduced or avoided by ensuring similar axial stress levels in adjacent vertical elements and a similar modulus of elasticity, which may be difficult to achieve in some cases. For example, if there is a transition in the plan area or shape of the building on a particular floor, one column may consequently support a much smaller load than an adjacent column.

The effects of creep and shrinkage deformations can be reduced by including additional steel reinforcement, ensuring adequate initial curing and using concrete mixes with lower potential for significant drying shrinkage. The preparation of a thorough specification covering all concrete materials, curing and construction techniques is vital.

Selection and procurement of materials

Concrete technology can be used to increase the modulus of elasticity of concrete, reducing elastic deformations and minimising the effects of creep and shrinkage strains; the increase depends on the volume of the cementitious matrix (cement, fly ash, or silica fume) and the stiffness of the aggregate (Carreira & Poulos 2007^[40]).

Detailing

Partitions, cladding, curtain walls, lifts and plumbing must be designed to adjust to the overall building movement and inter-story deformations. Normal serviceability criteria including cracking, deflection, acoustic performance, fire resistance and vibration response should be considered during the design process. Careful consideration should be given to construction tolerances and floor deflections, particularly at the slab perimeter where cladding systems are attached.

Structural connections

Due to difficulties and uncertainties in the prediction of locked-in forces developing as a consequence of both changes in the structural system during the construction sequence and differential axial shortening, there is a tendency in the conceptual design stage to avoid rigid-framed connections of floors and supporting beams to cores and columns and instead use hinged connections.

However, it must be observed that this artifice reduces the redundancy of the building structure, which subsequently reduces the overall rigidity and energy dissipation capacity of the building structure with respect to dynamic disturbances such as wind and seismic activity (see Chapters 9 and 10).

11.4.2 Construction methods

Detailed studies of movement should be performed before construction so as to modify the construction sequence and counter the effects of movement as the structure is built. Alternatively, these effects could be compensated for by cambering the formwork or by the use of soft joints or pour strips, which can be in-filled at a later date during the construction sequence.

The effects of advanced core construction are difficult to assess accurately but can be examined using the construction-stage analysis software mentioned in Section 11.3.1 or, somewhat laboriously, via spreadsheet calculations in one-column analysis. As a rule of thumb for reinforced concrete structures, because core walls deform less than columns, advanced core construction increases differential movement. However, for hybrid structures with reinforced concrete core walls and steel columns, this construction method will reduce the differential movement.

Quality assurance and quality control procedures are necessary to verify that design requirements are met during construction and to avoid problems arising from creep and shrinkage (Carreira & Poulos 2007^[40]).

A primary consideration in tall-building movement is the structure interface with various follow-on trade construction, for example, the attachment of cladding and internal partitions. A specification should be prepared to clearly indicate tolerance, movement and deflection criteria for various internal and edge conditions as they relate to the following elements:

Façade and cladding

The horizontal and vertical movements of a tall building can influence the design of joints between cladding panels, particularly at transfer floors in the structure and potentially at refuge and mechanical floors incorporating elements such as outriggers and belt trusses.

The movement that must be accommodated in the stack joint at these locations is primarily due to differential vertical movement between floors and the effects of axial shortening.

For external wall system or cladding fixed to the perimeter of the building at the spandrel beam or the slab edge, understanding and consideration of the following is required:

- Horizontal and vertical cladding joints and cladding panel tolerances
- Horizontal slab edge tolerances in plan and vertically
- Horizontal insert or cast-in bracket tolerances
- Sequencing of cladding attachment in relation to all fit-outs.

Lifts

Lift manufacturers will usually coordinate with architects on the overall plan dimensions of all lift shafts and pit dimensions, and these dimensions should be considered during the detailed design phase.

Fit-out

Engineers should have an understanding of the requirements or allowances for movement at the partition heads to accommodate both plan and vertical movements of floors above.

11.4.3 Preset (compensation)

Movement analysis conducted during the detailed design phase should identify problems associated with movement, and establish appropriate measures including the need for presets.

The main purpose of preset or construction adjustments and compensation is to provide a better geometrical configuration of the building throughout its service life, including the target time.

The following issues should be considered:

- Preset/compensation comprises essentially passive measures intended to limit undesirable changes to the geometry of the building structure induced by movement over time;
- Additional loads are created by overhanging parts of the structure that may be constructed subsequently. Corrections of lateral movement have a limited and temporary influence in reducing second-order effects and related changes in internal forces induced by these loads in vertical elements;
- Vertical geometrical preset is primarily used to allow the floors to remain level; they have no influence on the development of locked-in forces induced by the differential shortening of vertical elements;
- Various strategies may be used for preset. The choice depends on the implications and difficulties of the methods required to introduce the necessary compensation and benefits expected in the performance of the building;
- If a preset is used, usually only differential UPTO movements are compensated (see the right-hand side in Figure 11.8) and additional geometrical compensation is introduced to counteract the effects of expected differential SUBTO movements, ignoring the geometrical consequences of absolute shortening;
- If the theoretical geometry of the building must be maintained at a target time, geometrical compensation must counteract the total UPTO and expected SUBTO movements at that time. It is preferable to minimise the amount of preset during construction through the use of a partial preset and allow the remaining movement to be absorbed by non-structural elements;
- If the movement requires a large amount of preset, design changes should be considered instead.

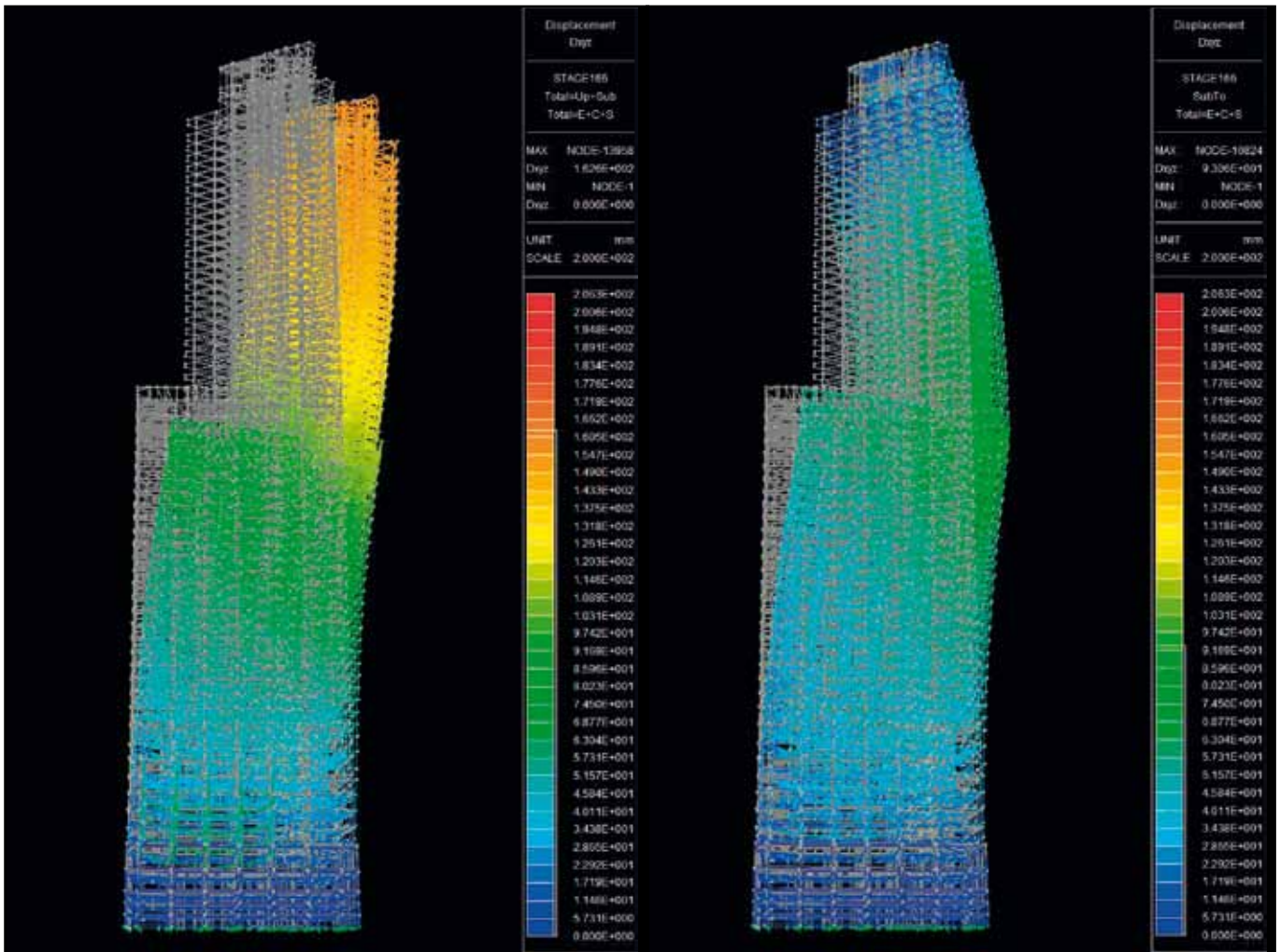

Figure 11.8

Example of building movement in three-dimensional space (left) and the result of preset only for UPTO movement (right).

Image: Daewoo Engineering and Construction.

Consultation between structural engineers and contractors is necessary to ensure contractors can preset building levels and locations to account for any settlement, axial shortening and deviation from verticality of the structure over the course of construction. This must be a joint effort because the sequence, loading and follow-up actions at every point within the program must be fully understood and calculated.

The levels of certain elements on each floor may have to be cast higher than the desired final level by varying amounts predicted by calculations. Contractors will have to regularly monitor the levels of all the elements on each floor as construction advances and report these to the designer. These levels should be compared to the calculated values; the target levels for subsequent floors may be adjusted based on the actual movement. If conducted collaboratively using the same approach as in the original design, an improved result can be achieved.

11.5 Tolerances

In addition to dimensional variations in fabrication and installation, each element of a building is subject to the effects of the environment, causing additional movements and dimensional changes after installation. Many building codes and other industry standards provide construction tolerances, with some accounting for movement effects.

However, these tolerances do not explicitly include changes in position resulting from structural movements due to deflections, settlements and temperature changes. This omission is not normally a problem, however, since construction tolerances are typically quite liberal and structural movements for most buildings, even tall buildings, are relatively small.

Tolerances are typically specified relative to the theoretical building lines and it is customary to concentrate on those expected to have significance to follow-on trades and future users. The overall building tolerances or deviations should be summarised or tabulated for each element type or feature including, but not limited to, the following:

- Pile plan position and cut-off
- Retaining wall position
- Plan position and shapes of walls, columns and openings
- Verticality (plumb) of columns and wall elements
- Pre-camber position
- Floor levelness over a plan area
- Vertical cladding tolerance
- Abrupt changes in surface level
- Cast-in fixing/insert position and level
- Straightness and length.

The attachment of follow-on trade construction such as cladding, raised floors and ceilings should allow for a combination of construction tolerances and movements when the building is in service.

Local building codes and standards may not always provide relevant guidance on tolerances for tall building construction (BSI 1990^[41] and ACI Committee 107 2010^[42]). Construction tolerances are related to the position in which the elements of the structure are cast and deemed to be pre-strike. Any movement or deflection after the removal of the formwork/falsework or medium- to long-term settlement, shrinkage, creep, shortening or thermal effects is not included.

In BS 5606:1990, building movement is classified as 'inherent deviations' due to the structural shape, the loading, the material properties, and the construction sequence. Hence, the provisions will depend on the design concepts, the joint details, the materials involved and their predicted behaviour (BSI, 1990^[41]). Therefore, the tolerances on building movement and results should be fully discussed, understood and shared among designers, general contractors and speciality subcontractors to mitigate potential problems at the construction stage and at occupancy.

12. Materials

Material technology has advanced significantly, along with construction product development, to provide designers with a far greater potential and ability to increase construction efficiency.

Concrete technology has benefited from research and market focus, allowing designers to fine-tune concrete for specialist applications, including tall building construction.

12.1 Concrete

Throughout this guide the standard European nomenclature for concrete strengths is used as, for example, C50/60. The prefix 'C' is used for normal and heavyweight concretes. The prefix 'LC' is used for lightweight concretes. The first number is the cylinder strength in MPa. The second number is the cube strength, again in MPa.

12.1.1 Foundations

Foundations for tall buildings tend to require large volume pours for rafts or piled rafts. Consideration should be given to the use of additions such as ground-granulated blast-furnace slag (ggbfs) or fly ash to reduce the initial heat of hydration and, thus, early thermal cracking. The level of additions tends to be around 50-70 % although 80 % ggbfs has been used. Although it is normal to specify the strength of concrete at 28 days, the foundations are sized for the permanent works and the early stresses applied to the foundations are significantly lower than the permanent stresses. The concrete can therefore be allowed to take 56 or 90 days to reach the required strength.

Figure 12.1
Strength ratio of different levels of additions over the period from one day to 90 days. Typically, strengths are specified as a 28-day strength.

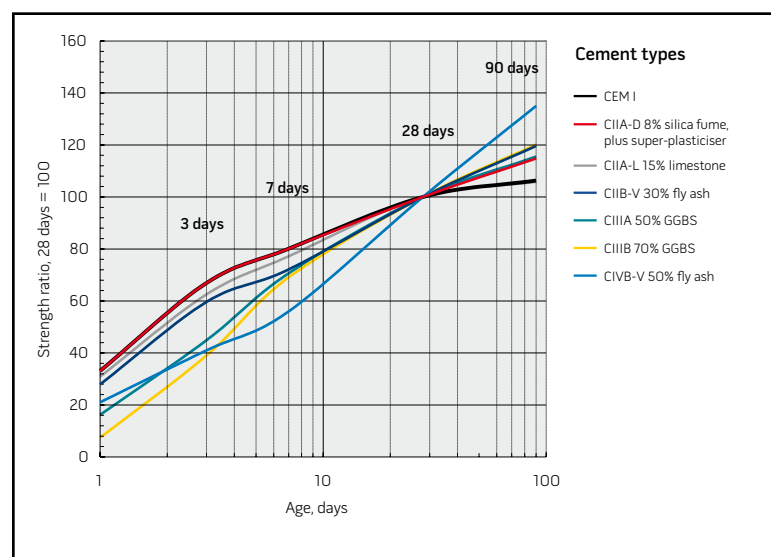

12.1.2 Superstructure

Tall buildings tend to use high-strength concrete for vertical structural elements due to significant savings in the area taken by the vertical structure being available. High-strength concrete can be considered to be strengths above C50/60. Most concrete tall buildings above 30 storeys use high-strength concrete, where available.

Concretes for tall buildings are required to be pumpable from ground level up to the level being served. This requirement affects the design of the concrete mix. If the concrete is to be pumped more than 30 storeys high, current concrete technology is such that the concrete will be a high-strength concrete even if a normal-strength concrete is specified. This can be considered in the initial design to optimise the design of the horizontal elements as well as the vertical elements.

The benefits of using high strength concrete^[43] are particularly noticeable for the vertical elements and, typically, this is where high-strength concrete is used. The size of the columns can be reduced by about 40 % by doubling the strength of the concrete. Walls tend not to be so highly stressed as columns because the loads are similar to those in the columns but are spread over the greater area of the wall. High-strength concretes have a higher Young's Modulus than normal strength concretes and, therefore, they experience fewer strains. Creep and shrinkage are also lower in high-strength concretes. To reduce differential shortening between the columns and the walls the designer should consider using different strengths of concrete for each, if the stresses are not similar.

Since the Young's Modulus of concrete is higher in higher strength concretes, slabs (frequently governed by deflection criteria) can also benefit from the use of high-strength concrete.

In an in-situ frame, the slab-to-column or beam-to-column junction should be considered if high-strength concrete has been used in the vertical structure but not in the horizontal structure. The portion of concrete at the beam-to-column or slab-to-column junction is typically poured with the beam or slab. This gives a portion of lower-strength concrete in the column at the junction. At internal columns this section of the concrete can be considered as confined and therefore can take greater stress than unconfined concrete. As a rule of thumb, this increased capacity can be considered to be $1.4 \times f_{cd}$ of the slab or beam concrete^[44].

High-strength concretes are less ductile than normal-strength concretes and, therefore, the reinforcement should provide ductility in the form of links for columns and, where required, walls.

Figure 12.2 gives the stress/ strain curve detailed by the parameters in Eurocode 2 (EN 1992-1-1) showing that, as the strength of concrete increases, the plastic plateau, from the strain at which the characteristic strength is achieved to the ultimate strain, reduces from 1.5 to 0 permille (‰).

This lack of ductility has also been resolved by using steel-fibre reinforcement together with the normal bar reinforcement^[45].

Figure 12.2
The stress/ strain curve detailed by the parameters in Eurocode 2 (EN 1992-1-1)

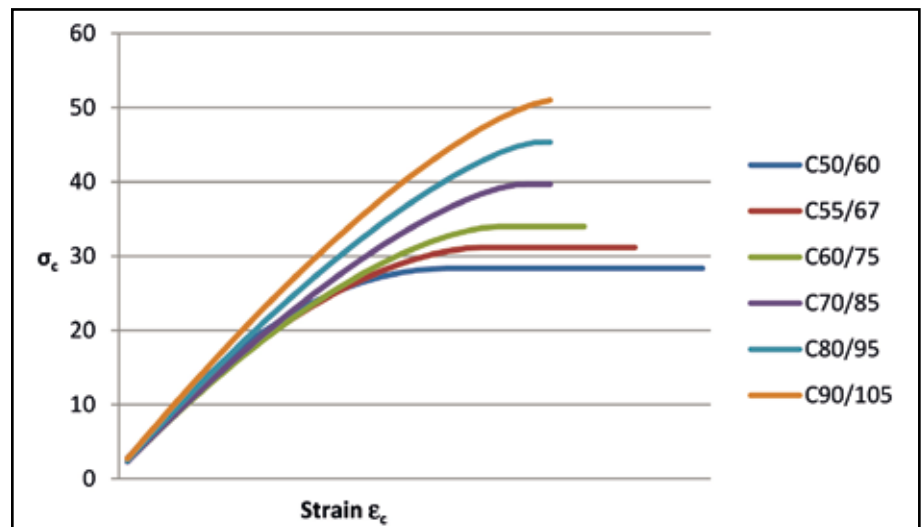

High-strength and high-performance concretes can be more prone to spalling than normal-strength concretes. This phenomenon is increased if silica fume has been used in the concrete mix, which is quite common for the higher-strength concretes (>C70/85). Silica-fume concrete has a susceptibility to explosive spalling, which is the form of spalling most avoided. The type of aggregate also has an influence on susceptibility to spalling. Lightweight and basalt aggregates are less likely to spall whereas siliceous gravel aggregates are more likely^[46].

Research on a series of tunnel fires in the EU has concluded that the use of polypropylene microfibres in the concrete mix has the most beneficial influence on the likelihood of spalling, eliminating the risk in high-strength concretes (but not ultra-high strength) concretes (>150 MPa). EN 1992-1-2 specifies a dosage of more than 2 kg/m³ of monofilament, polypropylene fibres to reduce the possibility of spalling in high-strength concrete but this dosage can be reduced if supported by test evidence. The addition of microfibres has an effect on the pumpability and strength of the concrete and, therefore, the concrete producer should be consulted to optimise the design of the concrete mix.

12.1.3 Buildability

Buildability was discussed in Chapter 6; the concrete mix will be heavily influenced by buildability requirements. Early-age strength requirements vary between the different construction methods and, therefore, the concrete mix will also vary. The concrete producer should have trialled the different concrete mixes to be used before start on site.

Self-compacting concretes can be useful in the construction of tall buildings where there might be dense reinforcement with little space for normal compaction. This should be considered in the design stage if the reinforcement becomes too congested^[47].

12.2 Reinforcement

Reinforcement production and supply varies greatly around the world. During peaks in construction activity, reinforcement may also be imported and care should be taken to ensure it complies with the project specification. Engineers should seek advice on material supply early in the design process.

The primary material properties of interest to engineers are, typically, strength and ductility. Ductility is particularly important in seismic zones. However other properties might also be important, for example, bond and weldability. Engineers will also need to ensure that reinforcement is compatible with the concrete design standard.

Proprietary reinforcement systems

There are numerous proprietary systems available to increase construction efficiency including:

- Continuity systems – such as couplers and bent-out bar systems
- T-headed reinforcement
- Prefabricated punching-shear and movement joint-shear connectors
- Prefabricated reinforcement (such as carpet, beam and column cages) including bent mesh
- Prefabricated balcony systems (to prevent a thermal bridge).

It is not possible to provide a global product list here but engineers are encouraged to research and discuss this early on with the contractor.

12.3 Time-dependent properties

The time-dependent properties of hardened concrete that influence building movements and variations in the internal forces are the stress-induced strains (initial-plus-creep strains) and the stress-independent strains such as shrinkage and temperature-induced strains. Here, attention is focused on stress-induced and shrinkage strains; temperature effects are discussed in Section 7.6.

For the prediction models in the current design recommendations and technical guides mentioned in Section 11.3.2, *fib* Model Code 2010 (*fib* 2013^[29]) and the ACI 209 guides (ACI Committee 209 2005, 2008 and 2011^[31, 32, 33, 34]) contain basic definitions and assumptions for stress-induced strains and shrinkage strains in concrete and detailed information on their physical mechanisms and influential factors.

For the purposes and scope of this chapter, the following basic elements should be noted:

- Shrinkage strains and stress-induced strains are considered additive.
- Stress-induced strains are normally separated into an initial nominal elastic strain and a creep strain; however, designers must be aware that this separation is a matter of convention. Creep strains develop very rapidly during and immediately after the application of the stress, and consequently the initial nominal elastic strain contains creep that occurs during the time between the application of the stress and the measurement of the strain. If this separation is assumed, the initial and creep strains

must be defined consistently so that their sum corresponds to the measured stress-induced, time-dependent strain.

- Within the range of service stresses, the stress-induced strain is considered an age-dependent linear viscoelastic behaviour for concrete, combining the assumptions of linearity and superposition of the strain responses to stresses applied at different times.

According to these basic definitions and assumptions, when considering only shrinkage as a stress-independent strain, the total time-dependent strain $\xi(t)$ in hardened concrete at time t under a constant imposed stress σ applied at a concrete age t' may be defined by the following equations:

$$\begin{aligned}\xi(t) &= \xi_{\sigma}(t, t') + \xi_{sh}(t) \\ &= \sigma J(t, t') + \xi_{sh}(t)\end{aligned}$$

$$J(t, t') = \frac{1}{E_c(t')} + C(t, t')$$

where $\xi_{\sigma}(t, t')$ is the stress-induced strain, $\xi_{sh}(t, t')$ is the shrinkage strain, $J(t, t')$ is the compliance representing the stress-dependent strain per unit stress, $E_c(t')$ is the nominal initial modulus of elasticity for the concrete associated with the nominal initial elastic strain $1/E_c(t')$ per unit stress, and $C(t, t')$ is the creep strain per unit stress.

For a variable imposed stress $\sigma(t)$, in the frequently assumed case that the law of variation of the imposed stress is continuous after an initial finite step $\sigma(t_0)$ at age t_0 , the stress-induced strain at time t is given by the expression:

$$\xi_{\sigma}(t) = \sigma(t_0) J(t, t_0) + \int_{t_0}^t J(t, t') d\sigma(t')$$

This equation, a linear Volterra integral equation, represents a constitutive law for the strain response of concrete to variable imposed stresses. Prediction models for concrete creep usually provide information for the prediction of the compliance $J(t, t')$ on the basis of a set of the most significant parameters.

13. Structural design

This chapter is set out as a series of notes. The intention is that they will form a quick reference for the experienced engineer needing guidance on aspects of design and analysis that are particular to tall buildings.

The notes are brief, for quick reference. Where further detail is required on the application of the various methods, the reader should refer to specialist literature. References are listed at the end of the guide.

These notes bring together the best of international good practice. In addition, of course, designers should refer to, and comply with, the building codes or regulations that exist in the jurisdiction where the building is to be constructed.

The notes are arranged to coincide with three broad stages of design:

- **Concept design.** At this stage, a minimum level of analysis and a series of 'structural engineering targets' as rules of thumb are recommended. The aim is to achieve a suitable design quickly. See Section 13.1.
- **Scheme design.** At this stage, specialised testing and analyses are required to verify the suitability of design. Many of the methods listed in scheme design will replace the quick and approximate methods recommended in the concept design stage. See Section 13.2.
- **Detailed design.** A full set of detailed documents is required, proving the acceptability of the design and calculations to demonstrate the design meets them. The methods follow on closely from those used in scheme design. See Section 13.3.

The fundamental aims and requirements for the structural design of a building do not change with its height. There are, however, some areas that become more important as the building becomes taller. These are listed below:

- **Dynamic component of wind load.** Gusty, time-varied wind loading may induce a resonant sway response of the whole building.
- **Occupant comfort criterion.** Horizontal movements of the building during a wind storm can cause discomfort and/or motion sickness.
- **Response to seismic ground shaking.** Displacements and forces induced by seismic ground shaking are complex. A tall building will need a more subtle form of analysis taking account of the nonlinearity and multi-modal nature of the building response.
- **Differential vertical movement.** Vertical shortening of the structure is greater; the differences between adjacent elements can be significant.
- **Column restraint.** Column forces are large, as is the restraint requirement.
- **Foundation behaviour and capacity.** Overall foundation capacity can limit feasible height. Foundation movements may cause significant effects in the superstructure.

13.1 Concept design

13.1.1 Objectives

Work with the rest of the design team to decide on:

- **Height**
- **Number of storeys**
- **Form of stability system**
 - Columns, core, moment frame, outriggers, external tube, belt trusses, added damping etc.
- **Key structural dimensions**
 - Column and wall positions and slab and beam depths.
- **Structural form of floor slabs and framing**
 - Column forces are large, and restraint is required.

13.1.2 Essentials

- **Assess seismic hazard at the site.** If doubt exists, seek the advice of a competent specialist. EC8 part 1 section 3.2.1 (2011) has a useful definition of 'very low' and 'low' seismicity. If seismicity is 'very low', it is not generally necessary to carry out additional analysis and checking for seismic ground shaking effects.
- **Consider shear flexibility of the core.** The core will consist of a number of shear wall elements linked by lintel beams. The stiffness of these beams will have a very significant effect on the degree to which the core acts as a single structural element.
- **Consider effect of doorways and other openings in outriggers.** The stiffness of an outrigger element has a significant effect on the overall stiffness of the stability system.
- **Consider lateral restraint of walls.** Some walls may not be laterally restrained by floor slabs; for example, where a wall separates a lift shaft from a stairwell. Keep a careful eye on their slenderness.
- **Design-in sufficient torsion stiffness.** A twisting response to wind or seismic ground shaking will generate high lateral accelerations at some points in the floor plate. This could lead to discomfort among building users and/or high seismic deformations.
- **Arrange structural system to dissipate sufficient energy during seismic events.** Essential requirement, except in areas of low or very low seismicity.
- **No brittle failures of elements during design seismic event.** Always required, though no additional checking needed in zones of very low seismicity.

Additionally, in zones of low, medium or high seismicity:

- **'Weak beams, strong columns'.** The stability of a building during a seismic event depends on repeated ductile deformation. Choice of structural system and geometry is crucial: size ductile elements to become plastic. Size non-ductile elements, such as columns, to remain elastic even when the deformation of ductile elements is generating moments and forces greater than the nominal element capacity.
- **Avoid transfer structures.** Vertical ground shaking can generate very significant additional vertical forces on transfer structures and long or heavy spans or cantilevers.
- **Regular plan form and elevation.** Abrupt changes in stiffness and mass distribution generate large additional deformations and forces.

- **Centre of lateral stiffness at centre of mass.** Eccentric floor plates twist under seismic conditions, generating large additional deformations and forces.
- **Consider load path for seismic base shear and moment.** Foundations will be subject to very high forces in seismic events.

13.1.3 Structural engineering targets

- **Minimise weight of floor slab and framing.** This will reduce column loads, increase the natural frequency, and reduce seismic demands. It should also reduce the embodied carbon and resource demand. Be aware of the economics of relevant industry; the viability of your project may depend on it.
- **Maximise proportion of the building dead load carried by the stability system.** The stability system must resist overturning, generating moments or uplift forces. Columns, walls and foundations are all simpler, stiffer and cheaper if they remain in compression at all times. Will also reduce the need for foundations resisting tension.
- **Size the stability system to achieve no tension in service.** In vertical elements of the stability system, cracking has a very significant effect on the stiffness of a reinforced concrete element. If walls and columns do not see tensile stress in service, assume un-cracked section properties in the analysis. This reduces the need for tension capacity in foundations.
- **Overall deflection under wind load less than, for example, $H/500$.** The aim here is to arrive at a design achieving the occupant comfort criterion, to limit p-delta effects and allow practical detailing of the cladding. $H/500$ will be superseded in later design stages by more specific checks for comfort and cladding movement.
- **Prefer no horizontal movement under vertical loading.** Effects can be offset by presetting but this complicates the construction process.
- **Prefer differential shortening of vertical structure less than $\text{span}/500$.** Where span = distance between vertical elements. This is a serviceability criterion and is not widely codified. Could go to $\text{span}/200$, as long as the effects of this are followed through in building design and the specification of the following trades.
- **Prefer that wall compression reinforcement does not need containment links.** Applies only in areas of very low seismicity, and is code-dependant. At 2% compression steel, BS 8110 requires the addition of links, and costs increase disproportionately.
- **Integrate wall layout with lifts, stairs and risers.** Core efficiency can have a significant effect on the economic viability of the project.
- **Integrate outriggers with building function, such as plant floors.**
- **Coordinate service routes with lintel beam depths and/or openings.**
- **Design core walls as self-stable during construction.** This will make the construction process simpler and safer and will reduce the build cost.

13.1.4 Analysis methods

- **Build an analysis model.** Use your favourite analysis software. Some people work by hand at this stage. The model should be simple to build and amend, so that alternatives can be looked at quickly. It does, however, need to be detailed enough to pick up the significant structural effects.
- **Model core using linked stick elements or using 2D elements.** The 1D element modelling method recommended by Cross in the book edited by Melchers and Hough represents each section of shear wall as a single stick element and links them with horizontal stiff arms and lintel beams. This produces accurate results with a small number of elements. It is straightforward to use the force and moment output in ultimate capacity checks and rebar design. Alternatively, programs such as ETab and Strand allow representation of the walls using 2D elements.
- **Use sufficient elements to model behaviour when using 2D.** Meshes need to be carefully refined at lintel beams, lintel beam connections and around builders' work holes. 2D meshes that are too coarse can cause significant errors.
- **In 2D analysis be careful** that linked freedoms do not limit the structural action of the lintel beam elements. Linking freedoms at floor levels will cause errors if lintel beams are modeled using 2D elements.
- **Model rotational flexibility of lintel beam connection to shear wall.** Lintel span can be increased by $d/2$ each end or effective EI can be reduced.
- **Floor diaphragm action can often be modelled by linking freedoms in the model.** A rigid link in the xy plane at each floor level is a convenient way to simplify the model. Care is required, however, to ensure this does not mask important structural actions. Only use if in-plane effects are not significant. Be careful of using it with outriggers or mega bracing.
- **In stick element modelling, consider neglecting minor axis and element torsion effects.** If minor axis and torsion effects are not required for the functioning of the stability system, consider setting I and J values for the core wall to zero so that they are not considered in the analysis.
- **Use appropriate E values for duration of loading.** Short-term E can be used for wind loading; long-term E is required for dead and live load analysis.
- **Use cracked-section-properties analysis.** Cracking has a marked effect on the distribution of forces in the structure and overall deflection of the building. It is probably sufficient at this stage, however, to use $I(\text{cracked}) = I(\text{un-cracked})/2$. Sections without tensile stress in service will be un-cracked. Ideally this will include all columns and walls. Sections subject to tensile stresses will be cracked, probably including all lintel beams and other sections.
- **Use wind load from code, with appropriate dynamic augmentation.** If doubt exists, consult a competent specialist.
- **Include notional horizontal load in accordance with the code you are using.**
- **Use live-load reduction in accordance with the code you are using.**
- **P delta analysis may be required.** The response of the stability system to horizontal load may well be amplified by the combined influence of the gravity loads and the deflection of the system. Evaluate this effect and use P-delta analysis if it is significant.

Additionally, in zones of low, medium or high seismicity:

- **Extend your static analysis model.** Extend your static analysis model for use in linear response-spectrum analysis. The model will need to represent all the building mass, its distribution in plan over each floor plate and the columns supporting it.
- **Carry out a linear response-spectrum analysis to EC8 or IBC.** This will offer a first approximation to the seismic deflections and forces.
- **Analyse sufficient modes to mobilise at least 90% of the building mass in x, y and z directions.** Analysis package should enable scaling of the modal dynamic results to the appropriate response spectrum for the site.
- **Use CQC method.** Combine the effects of individual modes into the total response for each direction.
- **Combine results from x, y and z responses.** In accordance with code; the SRSS method is recommended.
- **Choose q or R appropriately.** Take expert advice if doubt exists about the value of q or R to use. This will have a very significant effect on the design because of the direct effect on section strength demands.
- **Add 'accidental torsion'.** In accordance with code.
- **Confirm all sections can be designed with sufficient ductility.** Use rules from the selected design code.
- **Use over-strength factor.** In calculation of strength demand for non-ductile elements such as collectors, diaphragms and foundations.

13.2 Scheme design

13.2.1 Objectives

- **Finalise dimensions and setting-out of structural system.** Position and size of all vertical structure, elements of the stability system, and slab edges should be agreed with the design team and fixed.
- **Detailed coordination with other disciplines.** Finalise the interface between following trades and the stability system.
- **Produce scheme-stage drawings.** A report describing the system and how interfaces with the building design is often useful at this stage as well.
- **Produce estimates of concrete and rebar quantities.** Usually required for cost-checking.

13.2.2 Essentials

- **Determine whether wind-tunnel testing is required.**
- Check the limits of application of your wind code. The limits in BS EN 1992-1.4 are a useful guide:
 - $H < 200\text{m}$
 - $H/d < 5$; where d is the minimum horizontal dimension perpendicular to the wind.
 - **Plan form is rectangular**
 - **Building is prismatic.**

If your building lies outside these limits, wind tunnel testing will probably be required. Seek the advice of a competent specialist.

- **Determine whether Non-Linear Time History Analysis is required.**
- CTBUH 2008 Recommendations for the Seismic Design of High-rise Buildings, sets out the consensus view of the world's most experienced designers of high-rise structures in seismic zones. It recommends non-linear time history analysis (NLTHA) is required when:
 - $H > 50\text{m}$
 - **Seismic hazard is moderate or high.**

In zones of low, medium or high seismicity:

- **All structure and cladding to remain elastic during a seismic event with an average return period of 50 years.** Elastic response spectrum analysis can be used. See appendix B of CTBUH recommendations (2008).
- **No structural collapse during a seismic event with an average return period of 2,500 years.** Non-linear time history response analysis will probably be required. Refer to CTBUH recommendations (2008). Consult a competent specialist if lacking the capability for this type of analysis.

In zones of medium to high seismicity:

- **In seismic analysis, deformation is the critical parameter.** Collapse is prevented by the structure's ability to accept a sufficient extent of inelastic deformation.

- **Adequate strength prevents excessive deformation.** However, an excess of strength will lead to excessive forces in the structure.
- **Consider including gravity framing.** This can stiffen the building significantly and can be advantageous to include in the NLTHR analysis.
- **Brittle sections must remain elastic.** Elements without deformation capacity beyond yield are not permitted to experience inelastic deformation
- **Deformation demand calculated in the analysis must be less than the permissible value for that detail in ASCE 7-10 (2010).** For every structural element. If this condition is met, the collapse prevention requirement has been met.

13.2.3 Structural engineering targets

- **Ensure all sections can be reinforced economically.** Check all elements, particularly outriggers framing into core walls, shear in lintel beams, anchorage where beams span perpendicular to a thin wall, areas of tensile stress in core walls, and clashes where several beams frame into the same piece of concrete.
- **Storey drift under wind load coordinated with the cladding design.** The relative movement of one storey relative to the next will be very important in the design of the cladding system. Limit used in design should be agreed with the cladding supplier. Values in the range of $h/500$ to $h/200$ have all been used successfully in the past and $h/300$ probably strikes a good balance, while $h/400$ is easier for cladding suppliers to deal with.
- **Lateral acceleration under wind load is acceptable to occupants.** A dynamic consideration calculated in the wind-tunnel laboratory: it is influenced by the wind climate, building geometry, building mass distribution and stiffness, the geometry of the surroundings and the available damping.

13.2.4 Scheme stage analysis methods

- The scheme-stage analysis model should include sufficient detail to allow the design of every significant structural element.
- There are particular requirements if wind-tunnel testing and/or non-linear time

13.2.4.1 Analysis if wind-tunnel testing is not required

- Analysis methods are as described in the section on concept design but with a greater level of precision and more thorough coordination with the design team.
- It is likely that lateral accelerations will not cause significant discomfort or negative comment from building users.
- Either limit overall deflection to $H/500$ or check the lateral accelerations, as predicted by the National Building Code of Canada, are within acceptable limits.

13.2.4.2 Analysis if wind-tunnel testing is required

Carry out a dynamic analysis for wind response.

First, define:

- **The analysis origin.** In 3D, at foundation level, as near as possible to the shear centre of the building.
- **The analysis axes.** To coincide with directions of movement in first two modes, if possible.

Things to remember:

- **Model rotational moment of inertia of floor plates.** In order to model torsional effects.
- **Ensure first two modes are translational.** Rather than torsional.
- **Probably won't need pdelta analysis.** Lambda crit for the service state should be well above 10.

Then, use a modal dynamic analysis to prepare this data to send to the wind-tunnel laboratory:

- **Modal frequencies.** For first three modes.
- **Mode shapes.** For first three modes.
- **Floor-by-floor masses and positions.** Of centre of each floor mass, in 3D.

13.2.4.3 Wind tunnel testing

Take advice from a competent specialist, who is likely to recommend either a High Frequency Force Balance (HFFB) test or a Simultaneous Pressure Integration test. The process will be in two parts: model testing and post-processing. The post-processing stage can be re-run without re-testing.

For the testing stage, the wind-tunnel laboratory needs 3D external geometry of the building and the surroundings and the analysis origin and axes defined relative to the 3D geometry data.

For the post-processing stage, the laboratory needs:

- **Results from your dynamic analysis.**
- **Structural damping coefficient.** The amount of reliable data on actual damping in buildings is limited. Traditionally, engineers have used damping values of up to 3 %. Recent research into the behaviour of completed buildings suggests, however, that this may be an over-estimate. Further information can be found in CTBUH 2008, the paper by Smith, Merello and Willford, EN1991-1-4, and other research data.
- **Range of frequencies and mass to use for sensitivity analyses.** Use, for example, +/- 20 % to account for difference between calculations and real building behaviour.
- **Level of highest occupied floor for analysis.**
- **Building use.** Office or residential?
- **Acceptance criteria.** Use ISO 10137 (2007), as well as the appropriate national code.

The wind-tunnel laboratory should give you

- **Prediction of horizontal accelerations.** At upper occupied floor.
- **Acceptability of accelerations.** Relative to criteria.
- **Floor by-floor-loads.** To use as wind loading cases in detailed analysis.

13.2.4.4 Analysis, if non-linear time history is not required

If $H < 50\text{m}$: Design to EC8 or IBC using the elastic response spectrum analysis.

If $H > 50\text{m}$ but seismic hazard is low: Elastic response-spectrum analysis can be used. Appendix B of CTBUH 2008 sets out recommendations for the analysis:

- **Seismic hazard based on 2,500-year return period.**
- **Response spectrum based on 2% damping.**
- **Maximum demand to capacity ratio = 2.** Effectively equivalent to an assumption of q , or R , =2.
- **Ductile detailing required when demand to capacity >1 .** Structural components with strength demand to capacity ratios >1.0 should be detailed as components of an intermediate framing system to ASCE 7-10. When strength demand is less than capacity, specific seismic detailing is not required.
- **Foundations designed for elastic demand.** Or the maximum base moment and shear that the structure can deliver to the foundation, accounting for all possible sources of reserve strength.

13.2.4.5 Analysis if non-linear time history is required

If $H > 50\text{ m}$ and seismic hazard is moderate or high: Take advice from a competent specialist: There are two stages to the procedure: No damage in 50-year event, no collapse in 2,500-year event. A code-based analysis may be required in order to comply with local regulations, as well as to carry out the 'performance based design' procedure described below.

Elastic response spectrum analysis for 50-year return-period event:

- **Model similar to that required for wind analysis.**
- **Seismic hazard based on 50-year.** This will, in fact, vary with the jurisdiction and building importance.
- **Response-spectrum based on 2% damping.** See CTBUH 2008 appendix A.
- **Accidental torsion need not be included.**
- **All structure to remain elastic.**

Non-linear time history response analysis for 2,500-year return-period event:

- **Seismic hazard based on 2,500-year return period.** This will, in fact, vary with the jurisdiction and building importance.
- **Select earthquake histories.** In accordance with ASCE 7-10 (2010) and the seismic hazard assessment for the site.
- **Initial stiffness should take account for cracking up to the point of yield.** ASCE 41-06 (2007) Supplement 1 provides suitable guidance.
- **Damping prior to onset of yielding should not be greater than 2 %.** See CTBUH 2008, appendix A. Energy absorption after the onset of yielding will be explicitly modelled in the NLTHR analysis.
- **Post-yield force-displacement relationships based on ASCE 41-06 (2007).** Or other industry standard relationships, where they exist, and where they are appropriate.
- **Floor diaphragms.** Modelling must allow for calculation of diaphragm and collector forces and in-plane forces from transfer structures and outriggers.
- **Second order and p-delta effects will be required.** This analysis needs to account for the effects of significant deflections.
- **Accidental torsion need not be included.**
- **Number of analyses.** Required. Will depend on the choice of ground motion histories.
- **Output peak racking deformations and floor accelerations.** These are used for assessment of non-structural components. Racking deformations are often more meaningful than storey drifts.

13.3 Detailed design

13.3.1 Objectives

- A full set of construction drawings.
- A full set of structural justification calculations.
- A full set of materials and workmanship specifications.

13.3.2 Essentials

- **Adequate strength of all elements at ultimate limit state.** In non seismic design.
- **Adequate inter-storey drifts.** Relative to the limits agreed with the cladding supplier and, possibly, the partition supplier.
- **Adequate movements during construction.** These may affect lifts, partitions, cladding and other following trades.
- **Adequate occupant comfort due to lateral accelerations.** This effectively replaces a direct limit on overall deflections.
- **No damage in 50-year return-period earthquake.** No specific calculations required in areas of very low seismicity.
- **No collapse in 2,500-year return-period earthquake.** No specific calculations required in areas of very low seismicity.
- **Adequate robustness in extreme events.** As defined by local regulations and/or a specific risk assessment for the building.
- **Restraint of columns.** Lateral restraint of columns at floor levels: usually a percentage of the ultimate column load.
- **Tying of columns.** For robustness. Local rules may apply.
- **Robustness design of columns in perimeter.** To suit the risk assessment for the building. Design for a vehicle-impact load may be required or a justification of an alternative load path in the event of column failure.
- **Cast-in plates failure mode should be ductile.** Where connections into a core wall rely on cast-in steel fittings, ensure that the failure mode for the fitting is ductile. This means that beams connecting to the plates can be designed without assessing the effect of beam end rotations.

Additionally, in zones of low, medium or high seismicity:

- **Element detailing.** Must comply with the requirements of EC8 (2011) or ACI 318 (2008), as appropriate.

13.3.3 Structural-engineering targets

- **Construction joints in core.** Will need to coordinate with the formwork design and construction method. This will have an impact on the reinforcement detailing.
- **Detailing in core.** Must take into account the design of the jump form or slip form.
- **Beams and slabs framing into core.** Will need to be detailed using bend-out bars or couplers.
- **Incorporation of and allowance for construction tolerances.** Into the detailing of elements that frame into or attach to the core.
- **Temporary openings.** May be required in core walls for putlogs, crane ties or access to hoists.
- **Temporary loads.** Client may wish design of core to provide support to cranes, hoists or platforms.

13.3.4 Analysis methods

Ultimate limit state and seismic analyses

Similar to analyses in the scheme design stage except:

- **Final dimensions and details.**
- **Wind loading from wind-tunnel results.**

Serviceability limit-state analysis

- **Wind-deflection analysis.** Similar to ULS analysis but using characteristic loads and (probably) no need for ps-delta analysis. Gives inter-storey drifts to pass on to the cladding designer and designer of the internal partitions
- **Dead-load deflection analysis.** May be required to provide data to calculate presets: vertical, horizontal or floor slope. This should take creep and shrinkage into account in a multi-stage analysis.

References

1. CTBUH – Council on Tall Buildings and Urban Habitat, www.ctbuh.org
2. Rohan Rupasinghe and Eanna Nolan, *Formwork for Modern, Efficient Concrete Construction*, BRE, 2007
3. MPA The Concrete Centre, *Concrete Basements*, CCIP-044, 2012
4. Smith, R. Morello, O. Wallingford, M. 'Intrinsic and supplementary damping in tall buildings' *Proceedings of the ICE - Structures and Buildings*, Vol. 163, (2), April, pp. 111-118, 2010.
5. Ellis, B. 'Full-scale measurements of the dynamic characteristics of buildings in the U.K.' *Journal of Wind Engineering and Industrial Aerodynamics*, Vol. 59, (2-3), March, pp. 365-382, 1996.
6. Suda, K. Satake, N. Ono, J. Sasaki, A. 'Damping properties of buildings in Japan' *Journal of Wind Engineering and Industrial Aerodynamics*, Vol. 59, (2-3), March, pp. 383-392, 1996.
7. Kijewski-Correa, T. Young, B. Baker, W. Sinn, R. Abdelrazaq, A. Isyumov, N. Kareem, A. 'Full-scale validation of finite element models for tall buildings' *CTBUH 7th World Congress*, New York, October 16-19, 2005.
8. Balendra, T. *Vibration of Buildings to Wind and Earthquake Loads*, London, Springer-Verlag, 1993
9. CTBUH - Council of Tall Buildings and Urban Habitats, <<http://www.ctbuh.org/>>. June 2012.
10. National Research Council of Canada. Canadian Commission on Building and Fire Codes, *National Building Code of Canada*, National Research Council Canada, 2010.
11. Architectural Institute of Japan (AIJ)
12. Cermak, J.E. *Applications of fluid mechanics to wind engineering - A Freeman Scholar Lecture*, *Journal of Fluids Engineering*, ASME, (March): pp. 9-38, 1975
13. Davenport, A.G. *The implication of statistical concepts to the wind loading of structures*, *Proceedings of the Institute of Civil Engineers* 19, August, pp.447-472, 1961
14. Davenport, A.G. *The response of slender, line-like structures to a gusty wind*, *Proceedings of the Institute of Civil Engineers* 23, November, pp. 389-407, 1962
15. Davenport, A. G. *The buffeting of structures by gusts*, *International Conference on Wind Effects on Buildings and Structures*, Proceedings, Teddington, 1963
16. Davenport, A.G. 'A note on the distribution of the largest value of a random function,' *Proceedings of the Institute of Civil Engineers* 28, June, pp. 187-196. 1964
17. ISO 10137–2007, *Bases for design of structures - Serviceability of buildings and walkways against vibrations*, ISO (International Organization for Standardization), Geneva, Switzerland, 2007
18. Standards Australia/Standards New Zealand 1170.2, *Structural design actions, Part 2: Wind actions*, Standards Australia/Standards New Zealand, 2002
19. EN 1991-1-4, *Eurocode 1: Actions on structures - Part 1-4: General actions - Wind actions*, European Committee for Standardization, 2005
20. AIJ-RLB, *Recommendations for Loads on Buildings*, Architectural Institute of Japan, 2004
21. Cammelli, S., Wyatt, T.A. 'Higher modes of vibration in response of super-tall buildings to wind,' *35th Annual Symposium of IABSE / 52nd Annual Symposium of IASS / 6th International conference on Space Structures*, London, September 20-23, 2011

22. Harris, R.I., Deaves, D.M. 'The Structure of Strong Winds,' Paper No. 4, *Proceedings of the CIRIA Conference on Wind Engineering in the Eighties*, London, 12-13 November, Construction Industry Research and Information Association, London, 1981
23. American Society of Civil Engineers (ASCE), *ASCE Manual of Practice No.67 for Wind Tunnel Studies*, American Society of Civil Engineers, 1998
24. Australasian Wind Engineering Society, *Quality Assurance Manual - Wind Engineering Studies of Buildings*, AWES-QAM-1-2001, 2001
25. Bast, W. D., McDonnell, T. R., Parker, L., and Shanks, S. P., 'Measured shortening and its effects in a Chicago high-rise building', *Proceedings of the Third Forensic Engineering Congress*, San Diego, CA, pp. 564-576, 2003
26. Fintel, M., Ghosh, S. K., and Iyengar, H., '*Column shortening in tall structures – prediction and compensation* (EB108.01D)', Portland Cement Association, 1986.
27. Fintel, M., and Khan, F. R., 'Effect of column creep and shrinkage in tall structures – Prediction of inelastic column shortening', *ACI Journal*, Dec., Vol. 66, No. 2, pp. 957-967, 1969.
28. Ha, T., Lee, S. and Oh, B., 'Prediction and control of movement of high-rise buildings during construction', *fib Symposium PRAGE 2011*, Session 2B-4: Construction Technology, pp. 482-486, 2011.
29. *fib, 'fib Model Code 2010'*, Wilhelm Ernst & Sohn, Berlin, 2013.
30. Chiorino, M. A. and Sassone, M., 'Further considerations and updates on time dependent analysis of concrete structures', *Structural Concrete - Textbook on behaviour, design and performance*, 2nd edition, Vol. 2, Sec. 4.16, *fib Bulletin 52*, Lausanne, pp. 43-69, 2010.
31. ACI Committee 209, 'Analysis of creep and shrinkage effects in concrete structures (ACI 209.3R-XX)', *American Concrete Institute*, Farmington Hills, MI, 2011, 229 pp.
32. ACI Committee 209, 'Guide for modelling and calculating shrinkage and creep in hardened concrete (ACI 209.2R-08)', *American Concrete Institute*, Farmington Hills, MI, 2008, 48 pp.
33. ACI Committee 209, 'Prediction of creep, shrinkage, and temperature effects in concrete structures (ACI 209R-92, Reapproved 2008)', *American Concrete Institute*, Farmington Hills, MI, 2008, 47 pp.
34. ACI Committee 209, 'Report on factors affecting shrinkage and creep of hardened concrete (ACI 209.1R-05)', *American Concrete Institute*, Farmington Hills, MI, 2005, 12 pp.
35. Bažant, Z. P., and Baweja, S., 'Creep and shrinkage prediction model for analysis and design of concrete structures - Model B3', in: A. Al-Manaseer ed., *The A. Neville Symposium: Creep and Shrinkage - Structural Design Effects*, *ACI SP-194*, American Concrete Institute, Farmington Hills, MI, pp. 1-83, 2000.
36. Bažant, Z.P., Hubler, M.H., and Yu, Q., 'Excessive creep deflections: An awakening', *ACI Concrete International*, August, pp. 44-46, 2011.
37. Bažant, Z. P., Li, G.-H., and Yu, Q., 'Prediction of creep and shrinkage and their effects in concrete structures: Critical appraisal', *Proceeding of 8th International Conference on Creep, Shrinkage and Durability of Concrete and Concrete Structures - CONCREEP 8*, Vol. 2, T. Tanabe, et al. eds., CRC Press, Boca Raton, FL, 2009, pp. 1275-1289, 2009.
38. Gardner, N. J., 'Comparison of prediction provisions for drying shrinkage and creep of normal-strength concretes', *Canadian Journal of Civil Engineering*, Vol. 31, pp. 767-775, 2004.

39. McCafferty, P., Brodtkin, D., Farnsworth, D., and Scott, D., 'Engineering an icon – The Marina Bay Sands® Integrated Resort', *STRUCTURE magazine*, June, pp. 29-33, 2011.
40. Carreira, D. J., and Poulos, T. D., 'Designing for effects of creep and shrinkage in high-rise concrete buildings', *ACI SP 246-07*, pp. 107-132, 2007.
41. BSI, *Guide to accuracy in building (BS 5606:1990)*, British Standards Institution, 1990, 60 pp.
42. ACI Committee 107, 'Specification for tolerances for concrete construction and materials (ACI 117-10)', *American Concrete Institute*, Farmington Hills, MI, 2010, 80 pp.
43. *fib bulletin 42 Constitutive modelling of high strength / high performance concrete*: fib 2008
44. The Concrete Society, *Technical Report 49 Design guidance for high strength concrete*. 2010
45. The Concrete Society, *Technical Report 63 Guidance for the Design of Steel-Fibre-Reinforced Concrete*. 2007
46. The Concrete Centre, *CCIP-031 Performance of Concrete Structures in Fire*. 2011
47. The Concrete Society, *Technical Report 62 Self-compacting Concrete: A review*. 2005

Further Reading

- Yu, Q., Bažant, Z.P., and Wendner, R., 'Improved algorithm for efficient and realistic creep analysis of large creep-sensitive concrete structures', *ACI Structural Journal*, Vol. 109, No. 5, Sep-Oct. pp. 665-675, 2012.
- Sassone, M. and Casalegno, C., 'Evaluation of the structural response to the time-dependent behaviour of concrete: Part 2 - A general computational approach', *The Indian Concrete Journal*, Vol. 86, No. 12, Dec., pp. 39-51, 2012. Errata, Vol. 87, No. 8, Aug., p. 33, 2013.
- Chiorino, M. A. and Casalegno, C., 'Evaluation of the structural response to the time-dependent behaviour of concrete: Part 1-An internationally harmonized format', *The Indian Concrete Journal*, Vol. 86, No. 12, Dec., 2012, pp. 25-28, 33-36, 2012.
- Chiorino, M. A. and Carreira, D. J., 'Factors affecting shrinkage and creep of hardened concrete and guide for modelling - A state-of-the-art report on international recommendations and scientific debate', *The Indian Concrete Journal*, Vol. 86, No. 12, Dec., pp. 11-24, 2012. Errata, Vol. 87, No. 8, Aug., p.33, 2013.
- Baker, W. F., Korista S., Novak C., Pawlikowski J., and Young B., 'Creep & shrinkage and the design of supertall buildings. A case study: The Burj Dubai Tower', *ACI SP 246-07*, pp. 135-150, 2007.
- Sinn, R. C. and Abdelrazaq, A. K. *Robustness and Redundancy Design for Tall Buildings*, ASCE Structures Congress, 2000.
- Canisius, T. Baker, J. Diamantidis, D. Ellingwood, B. Faber, M. Holicky, M. Markova, J. Maitra, A. Narasimham, H. Sørensen, J. Vogel, T. Vrouwenvelder, A. *Structural Robustness Design for Practicing Engineers*, COST action TUO601 Robustness of Structures, 2011.
- Steel Construction Institute (SCI), *Composite Column Design to Eurocode 4: Based on DD ENV 1994-1-1: 1994 Eurocode 4: Design of Composite Steel and Concrete Structures: Part 1.1: General Rules and Rules for Buildings with Reference to the UK National Application Document*, Steel Construction Institute. 1994

- Johnson, R. Anderson, D. Designers' Guide to EN 1994-1-1: Eurocode 4: Design of Composite Steel and Concrete Structures. General rules and rules for buildings, Thomas Telford, 2004.
- International Standardization Organization (ISO), , *Basis for design of structures - Serviceability of buildings and walkways against vibrations*, ISO 10137-2007, Geneva, Switzerland, 2007
- National Research Council of Canada. Canadian Commission on Building and Fire Codes, *National Building Code of Canada*, National Research Council of Canada, 2005
- Paulay, T and Priestley, M. *Seismic Design of Reinforced Concrete and Masonry Buildings*, John Wiley & Sons, New York, 1992
- Naeim, F. *The Seismic Design Handbook*, 2nd edition, Springer, 2001
- Taranath, B, *Steel, Concrete and Composite Design of Tall Buildings*, 2nd edition, McGraw-Hill, 1998
- Council on Tall Buildings and Urban Habitat (CTBUH), *Recommendations for the Seismic Design of High-rise Buildings*, 2008. <http://www.ctbuh.org/>.
- Pacific Earthquake Engineering Research Center (PEER), *Guidelines for Performance-Based Seismic Design of Tall Buildings*, Version 1.0, November 2010
- Concrete Society, *Axial Shortening of columns in high rise buildings*, Concrete Advice 33, 2008.
- Melchers, E. and Hough, R. *Modeling Complex Engineering Structures*, ASCE press, Reston, Virginia, 2007
- Council of Tall Buildings and Urban Habitat. *Recommendations for Seismic Design of High-Rise Buildings*, available at www.ctbuh.org, 2008.
- Pacific Earthquake Engineering Research Center (PEER), *Guidelines for Performance-Based Seismic Design of Tall Buildings*, Version 1.0, TBI Guidelines Working Group. PEER Report 2010/05, Berkeley, California, , University of California, available at <http://peer.berkeley.edu/tbi/publications-reports/>, November 2010
- Los Angeles Tall Buildings Structural Design Council, *An Alternative Procedure for Seismic Analysis and Design of Tall Buildings Located in the Los Angeles Region*, available at www.tallbuildings.org, 2008.
- Smith, R. Merello, R. and Willford, M. 'Intrinsic and Supplementary Damping in Tall Buildings,' *Proceedings of the institution of the ICE – Structures and Buildings*, Vol.163, (2), pp. 111 – 118, London, 2010.
- International Code Council (ICC), *2009 International Building Code*, Cengage Learning, Washington DC, 2009

Case Studies

This chapter provides just some examples of tall buildings using concrete. The case studies have been selected to show a range of building use, storey heights and construction methods. There are also projects from across the world from cities such as London, Chicago, Mumbai and Shanghai.

The projects are:

1. Bank Boston Headquarters, Sao Paulo, Brazil	146
2. Shining Towers, Abu Dhabi, UAE	147
3. Torre Cajasol, Seville, Spain	148
4. Majunga Tower, Paris, France	149
5. Strata, London, UK	150
6. 500 West Monroe, Chicago, USA	151
7. Riviera Twinstar Square, Shanghai, China	152
8. Millharbour, London, UK	153
9. Ontario Tower, Chicago, USA	154
10. Worlie Towers, Mumbai, India	155
11. Damac Heights, Dubai, UAE	157
12. The Shard, London, UK	158

Bank Boston Headquarters, Sao Paulo, Brazil



PROJECT DESCRIPTION

STRUCTURAL SYSTEM: Shear-wall system

TYPE / OCCUPANCY: Commercial/ Office Building

STOREYS / HEIGHT: 30 storeys, 145 m

TOTAL AREA: 80,000 m²

FLOOR AREA: 2,000 m² maximum, 750 m² minimum

COST: \$65 M

COMPLETION DATE: 2002

This 30-storey building has a reinforced concrete shear-wall core, located at the internal re-entrant corner in the L-shaped plan of the building.

The shear walls are 450 mm thick at the base of the tower, reducing to 300 mm thick at the top. The structure is founded on rock, with variations across the site. This required the use of bored caissons or spread bases in close proximity to one another.

The basement structure is formed of 3 levels. The floor-framing system for the parking structure typically consists of 225 mm two-way flat slabs with drop panels at the columns. Columns are at a maximum of 9.0 metres in both directions within the parking areas.

The floor-framing system consists of a concrete one-way slab system with 800 mm wide by 750 mm deep post-tensioned concrete beams spanning 21 metres to reinforced concrete columns at 4.5 m centres in the open office area. Standard reinforced concrete beam and slabs are used for shorter spans around the core walls.

The column sizes vary as follows: 1,200 mm x 1,000 mm at the base, reducing to 1,200 mm x 750 mm for the most of the levels and 800 mm Ø columns near the top of the building.

PROJECT TEAM

CLIENT: Bank Boston

ARCHITECT: SOM

STRUCTURAL ENGINEER: SOM

M&E: SOM

MAIN CONTRACTOR: Hochtief

FRAME CONTRACTOR: Hochtief

Floor plate.

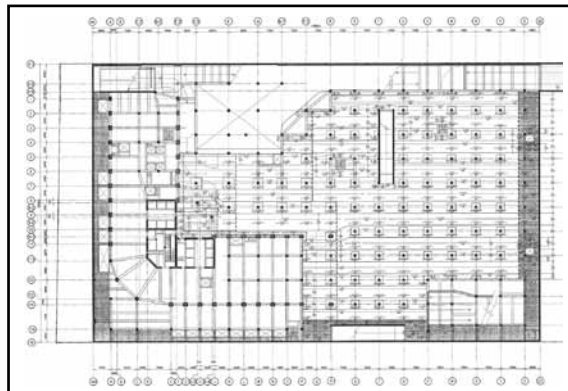

Shining Towers, Abu Dhabi, UAE



PROJECT DESCRIPTION

STRUCTURAL SYSTEM: Eccentric concrete cores, shear walls and framing action

TYPE/ OCCUPANCY: Two towers, one residential, one commercial.

STOREYS/HEIGHT: Residential - 33 storeys. Office - 42 storeys.

FLOOR AREA: 109,000 m²

COST: AED550 M.

COMPLETION DATE: 2012

The Shining Towers development in Abu Dhabi consists of two multi-storey towers: the curved tower providing residential accommodation and the tower with the leaning-effect providing office accommodation. The folding facade is designed to accentuate the leaning of the buildings and one of the towers twists about its axis.

The foundation is a mixture of piled raft and pile caps. The thickness of the piled raft varies from 2.25 m to 2.75 m. The building has three basement levels.

The stability system uses a building frame with a central core. The floors are post-tensioned slabs on reinforced and post-tensioned beams in the twisting tower and normal reinforced concrete slabs on beams in the other tower. The slab thicknesses vary to accommodate bending and shear forces on varying spans. The concrete for the horizontal elements is C40/50 and C50/60. The walls are 300 mm to 500 mm thick and the columns are 500 mm to 1,200 mm diameter. The concrete for the vertical structure is C40/50 to C65/80.

PROJECT TEAM

CLIENT: Foresight Investments

ARCHITECT: Aedas, H+H

STRUCTURAL ENGINEER: Ramboll Middle East

M&E: Ramboll Middle East

MAIN CONTRACTOR: Target

FRAME CONTRACTOR: Target

Floor plate.

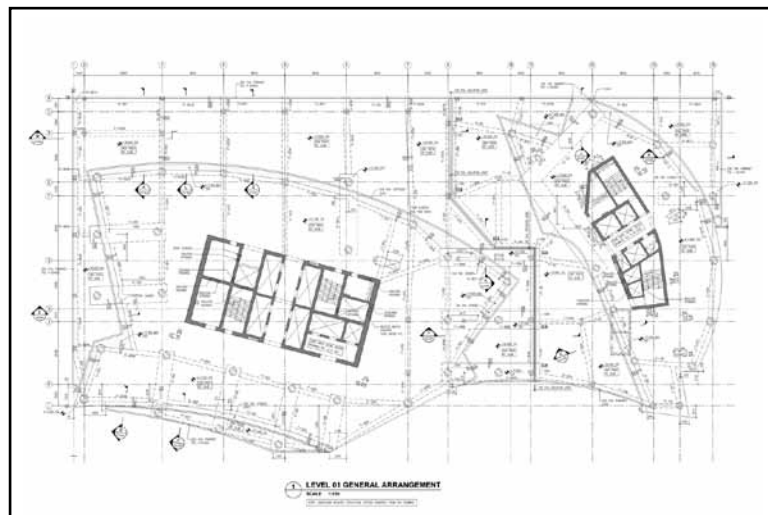

Torre Cajasol, Sevilla, Spain



PROJECT DESCRIPTION

TYPE / OCCUPANCY: Office Building
STOREYS / HEIGHT: 40 storeys – 178 m
COMPLETION DATE: Estimated 2014

The Torre Sevilla or Torre Cajasol is a 40-storey, 178 m office development in Sevilla, Spain. It is part of the masterplan of Puerto Triana and is situated on the site of the Expo 1992.

The stability system is an elliptical reinforced concrete core of 32 m x 16 m comprising walls of 400 mm – 700 mm thick with a concrete strength of C40/50. The columns are inclined composite columns of 1,000 – 1,200 mm diameter and a concrete strength of C30/37 – C65/80. The 350 mm-thick floor slabs are lightweight concrete with a 350 mm thickness spanning up to 9.6 m.

PROJECT TEAM

CLIENT: Cajasol
ARCHITECT: Pelli Clarke Pelli Architects
STRUCTURAL ENGINEER: Ayesa and Fhecor Ingenieros
M&E ENGINEER: Ayesa
MAIN CONTRACTOR: UTE FCC-INABENSA
PROJECT MANAGER: Aynova

Floor plate.

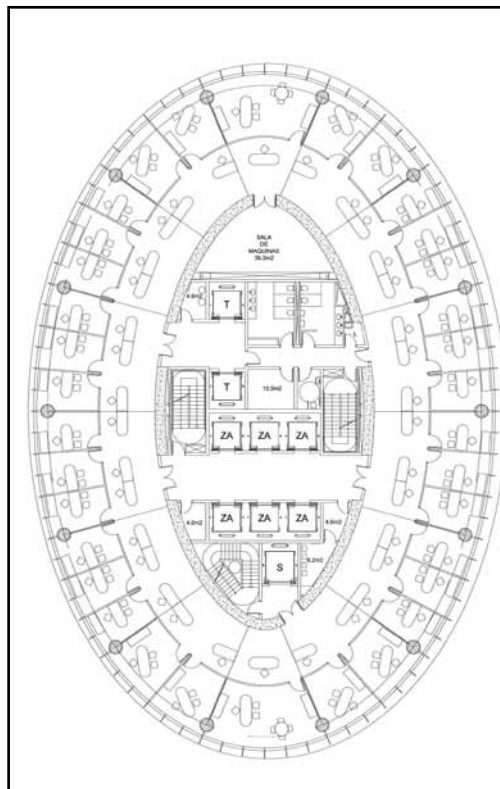

Majunga Tower, Paris, France



PROJECT DESCRIPTION

STRUCTURAL SYSTEM: Reinforced concrete core

TYPE / OCCUPANCY: Office Building

STOREYS/HEIGHT: 45 storeys – 195 m

TOTAL AREA: 63,200 m²

COMPLETION DATE: 2014

The Majunga tower is an office building with integrated parking at La Défense, Paris. It is 42 storeys and 180 m high above ground and includes 3 basement levels. The building design includes outdoor areas on every floor and 2,000 m² of accessible green spaces. The project has achieved a BREEAM 'Excellent' rating.

The tower is asymmetric in plan in relation to its core and this produced the shape of the tower, which is formed by three vertical strips.

The stability system is formed by the reinforced concrete core, plus reinforced concrete facade columns. The core walls are formed in C60/75 concrete and are 650mm and 300 mm thick. The columns are C80/95 concrete and 700 mm to 1,350 mm in diameter.

The foundation is a C45/55 concrete raft 2.2m thick, founded on limestone. The thickness of the raft was based on the need to limit deflection of the tower and the surrounding structures.

Columns are inclined on the east facade of the tower. This imposes significant forces in the floors, which are taken by the core. The floors are reinforced concrete slabs of 180 – 320 mm thick and supported on 500 x 700 mm deep façade beams.

PROJECT TEAM

CLIENT: Unibail Rodamco

ARCHITECT: Jean-Paul Viguier

STRUCTURAL ENGINEER: SETEC TPI

M&E: INEX

MAIN CONTRACTOR & FRAME CONTRACTOR: Eiffage Construction

Floor plate.
Image: Setec tpi

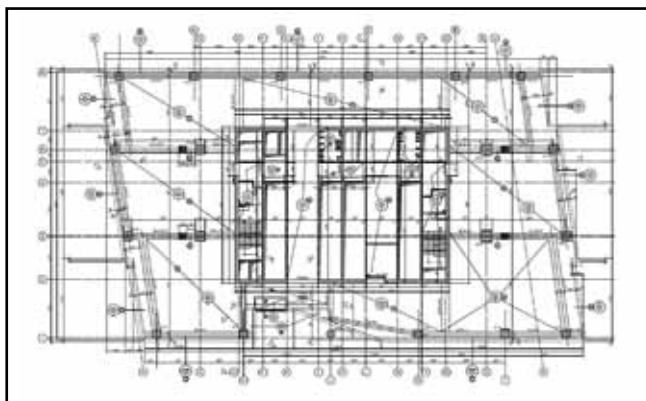

Strata, London, UK



PROJECT DESCRIPTION

STRUCTURAL SYSTEM: RC Core and RC wing walls

TYPE/ OCCUPANCY: Residential: 408 apartments

STOREYS/HEIGHT: 43 storeys – 147.9 m

FLOOR AREA: 34,000 m²

FRAME COST: £70M

COMPLETION DATE: 2011

The 43-storey, 147.9 m high, Strata tower is located in the Elephant and Castle district, London and provides 408 apartments for residential accommodation.

The building is recognisable by the three 9 m diameter wind turbines integrated into the top of the building.

This tall building has one basement level founded on bored piles, up to 1.5 m in diameter. The stability is provided by the reinforced concrete central core supplemented by reinforced concrete wing walls over the bottom 10 storeys. The walls are 225 mm to 500 mm thick and of C50/60 concrete. The C50/60 columns are typically 300 mm thick, varying in length from 300 mm to 2,400 mm. Walking columns are used to shrink the footprint of the building at the top and bottom of the tower. The 200 mm-thick post-tensioned floor slabs span 8 m along the façade and 10 m internally and are C32/40 concrete.

PROJECT TEAM

CLIENT: Brookfield Europe

ARCHITECT: BFLS

STRUCTURAL ENGINEER: WSP

M&E: WSP

MAIN CONTRACTOR: Brookfield Multiplex

FRAME CONTRACTOR: Buildstone

POST TENSIONING DESIGNER: CCL

POST TENSIONING CONTRACTOR: CCL

Floor plate.

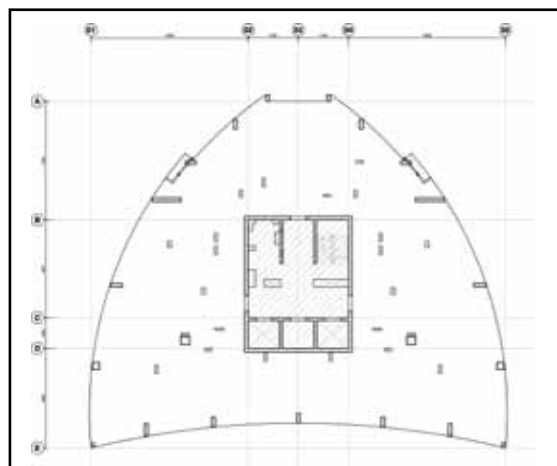

500 West Monroe, Chicago



PROJECT DESCRIPTION

STRUCTURAL SYSTEM: Shear wall and frame

TYPE / OCCUPANCY: Office Building

STOREYS / HEIGHT: 45 storeys – 183 m

TOTAL AREA: 148,650 m²

FLOOR AREA: 2,550 m², typical

COMPLETION DATE: 1992

The floors are formed of reinforced concrete slabs and post-tensioned beams on office floors, and post-tensioned beams and slabs on parking floors.

Post-tensioned beams on parking and office floors typically span 13.8 m and are generally 600 mm wide and 450 mm deep. Exterior multi-storey column transfer walls are used at offset column locations at the top of the building. Spandrel beams typically used in the frame are 600 mm wide and 810 mm deep with columns typically measuring 600 mm by 900 mm.

Columns are mostly 1,000 mm square at the base of the tower, reducing to 600 mm square near the top of the tower in many cases. Concrete strengths ranged from 100 MPa to 35 MPa.

Load balanced perimeter PT beam / column frames form the overall frame system that serves as part of the building's lateral stability system and serve to transfer column loads before column framing enters into parking areas.

PROJECT TEAM

CLIENT: Tishman Speyer Properties

ARCHITECT: SOM

STRUCTURAL ENGINEER: SOM

M&E: SOM

MAIN CONTRACTOR: MORSE DIESEL INTERNATIONAL

FRAME CONTRACTOR: MORSE DIESEL INTERNATIONAL

Floor plate.

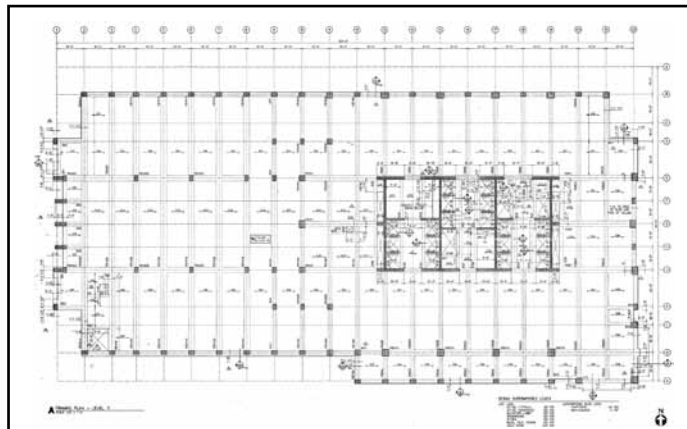

Riviera TwinStar Square, Shanghai, China



PROJECT DESCRIPTION

STRUCTURAL SYSTEM: Reinforced concrete core and perimeter frame

TYPE / OCCUPANCY: Office Building

STOREYS: 49 storeys – 216 m

TOTAL AREA: 196,000 m²

COMPLETION DATE: 2011

This office building, located in the Pudong New District of Shanghai, which is part of the main financial district. It is 216 m high, with 49 storeys above ground and four basement levels founded on 850 mm-diameter bored piles. It is paired with another tower and the two towers curve symmetrically towards each other.

The stability system uses a reinforced concrete core and a perimeter frame. The columns are 1,200 mm x 1,200 mm square and the core walls are 350 mm to 680 mm thick. Inclined columns are used at the curved elevation. The floor slabs are 110 mm – 125 mm-thick slabs on beams.

At the time of publication, this is the 30th tallest building in Shanghai.

PROJECT TEAM

DEVELOPER: China State Shipping Corporation; CITIC Pacific Group

DESIGN ARCHITECT: Arquitectonica

ASSOCIATE ARCHITECT: ECADI

STRUCTURAL ENGINEER: Arup

MEP ENGINEER: J. Roger Preston Group

MAIN CONTRACTOR: Shanghai Construction

Floor plate.

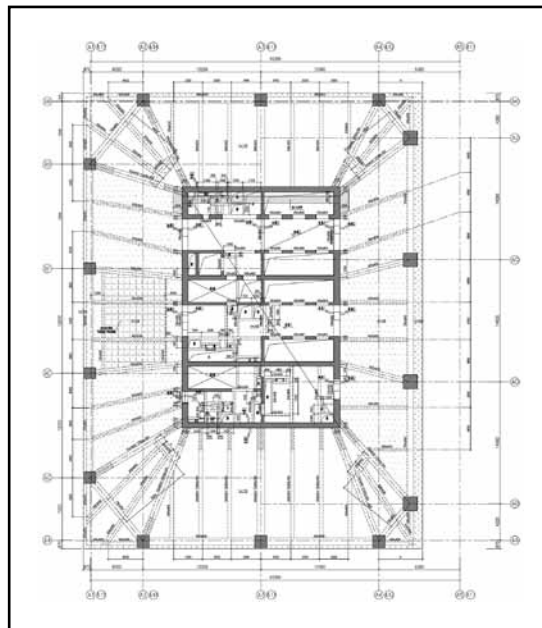

Millharbour, London, UK



PROJECT DESCRIPTION

STRUCTURAL SYSTEM: RC core and outriggers

TYPE/ OCCUPANCY: Residential

STOREYS/HEIGHT: 51/43 storeys

FRAME COST: £27 M

COMPLETION DATE: 2008

Part of the Millharbour Quarter development, this project is located in the heart of the Isle of Dogs, London.

The substructure of the building comprises a reinforced concrete raft foundation and a single-level basement. The basement was constructed using top-down construction, a technique latterly used at The Shard.

The super-structure has a reinforced concrete core plus outriggers. The outriggers were designed to engage perimeter columns to limit lateral accelerations. The floor slab is 200 mm thick with 7.6 m spans. Columns are 300/350 mm thick and 240/300 mm deep and used C70/80 concrete. Double-height in-situ concrete columns were used to accelerate the construction cycle. The walls are also RC concrete and are 300-450 mm thick.

PROJECT TEAM

CLIENT: Ballymore

ARCHITECT: SOM

STRUCTURAL ENGINEER: WSP

M&E: Hoare Lee

MAIN CONTRACTOR: Canary Wharf Contractors

FRAME CONTRACTOR: Laing O'Rourke

Floor plate.

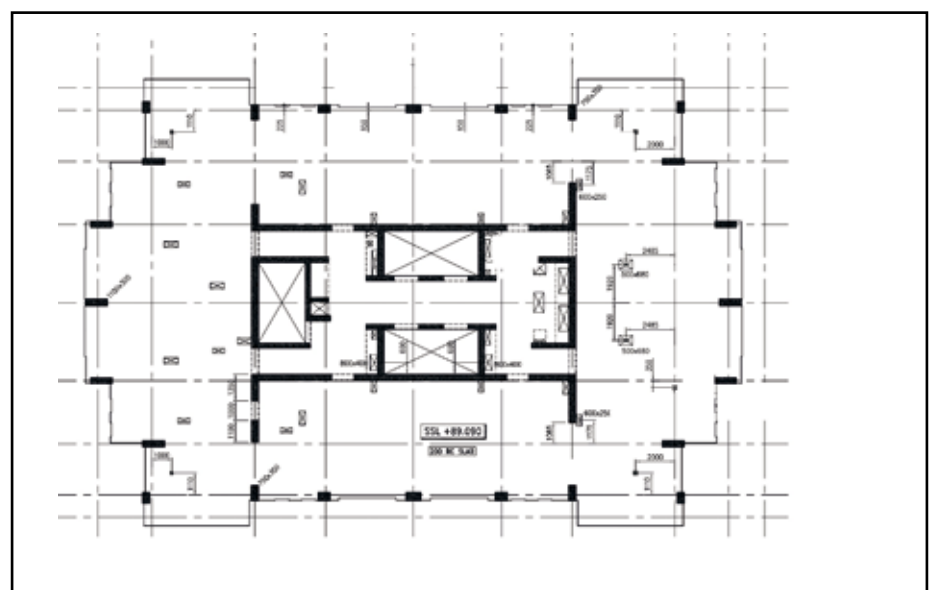

Onterie Centre, Chicago, USA



PROJECT DESCRIPTION

STRUCTURAL SYSTEM: Braced tube

TYPE/ OCCUPANCY: Office/Residential

STOREYS: 59 storeys – 174 m

FLOOR AREA: 85,470 m²

COMPLETION DATE: 1986

This residential and office building has 58 storeys above ground and a rectangular plan with insets on each long face. There is a single basement level providing parking and plant space. The basement-perimeter retaining walls consist of 500 mm thick reinforced concrete retaining walls. The basement slab is formed as a 150 mm on grade slab.

The foundations for the tower are formed of belled caissons, with the smallest pile having a shaft dimension of 760 mm and the largest a shaft dimension of 1,680 mm. The details required the installation of a temporary steel liner above the level of the belled base of the piles and the founding material at the base of the belled caissons is noted as approximately 1,450 kPa. All column loads are founded directly on individual piles with locally thickened caps.

The stability system used is a braced tube formed from reinforced concrete columns at close centres (1.7 m) and similar-width spandrel beams. Reinforced concrete infill panels in a diagonal pattern on each face form cross-bracing lines to provide additional strength and stiffness. They also create a distinctive architectural style. The column sizes range from 760 mm x 1,150 mm at the bottom of the tower to 600 mm x 700 mm at the top of the tower.

The building plan starts much wider at ground floor. The shape of the lower part of the tower is sloped inwards to the typical floor plan width at level 11. The lower floors are all flat slabs, with or without drop panels at the column positions, and of thicknesses varying from 180 mm to 215 mm. These levels comprise a mixture of retail, parking and commercial use. Downstand beams are used in some locations to support slightly longer spans or isolated locations of heavier load. The concrete for the slabs and beams is C35/45.

PROJECT TEAM

ARCHITECT: SOM

STRUCTURAL and M&E ENGINEER: SOM

Floor plate.

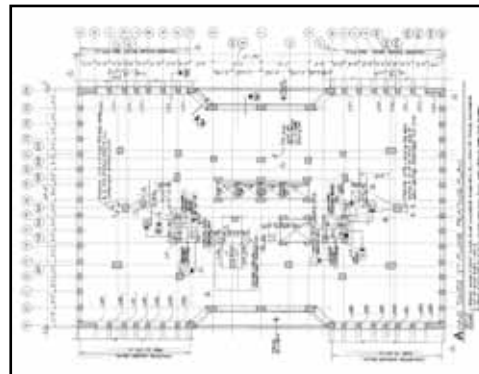

Worli Towers, Mumbai, India



PROJECT DESCRIPTION

STRUCTURAL SYSTEM: Core wall with gravity column on periphery; with outrigger for Tower 3.

TYPE/ OCCUPANCY: Mixed-use, mainly residential

STOREYS: 64-75 storeys – 252-307 m

TOTAL AREA: 415,000 m²

COST: INR 22.5 M

COMPLETION DATE: Estimated 2017

This development of three towers of 64, 75 and 77 storeys high will include offices, a hotel and apartments. There is a three storey basement and 15 storey podium across the project site on which the towers are constructed.

The stability system for the two taller towers is formed from the core walls with gravity columns on the periphery. The shortest tower uses the core walls with outriggers at the plant-room floors and gravity columns on the periphery. Core-wall thicknesses are 1,000 mm for the flange walls and 300 mm for the walls acting as webs.

The basement slabs are reinforced concrete flat slabs with drop panels and the superstructure slabs are post-tensioned flat slabs.

Concrete for the building was:

C50 with ground-granulated blast-furnace slag (ggbs) for the 4 m deep raft slab

C80 for the vertical structure from the B03 to the 35th floor

C70 for the vertical structure from the 36th floor to the 50th floor

C60 for the vertical structure from the 51st floor to the roof

C50 for the basement and podium slabs

C40 for the tower slabs.

The total quantity of concrete consumed in the foundation is 30,250 m³, with close to 225,000 m³ of concrete in the superstructure. Embedded thermocouples were used during construction to control the temperature in the raft and core walls.

The core walls and columns were constructed using jump-form. The building movements were monitored during construction.

PROJECT TEAM

CLIENT: Omkar

ARCHITECT: Foster and Partners

CONSULTING ARCHITECT: UHA

STRUCTURAL ENGINEER: Buro Happold

M&E: Buro Happold

LANDSCAPE ARCHITECT: LDA Design

WIND ENGINEER: RWDI Consulting Engineers & Scientists

MAIN CONTRACTOR: Larson & Toubro

Tower 2 typical plan.

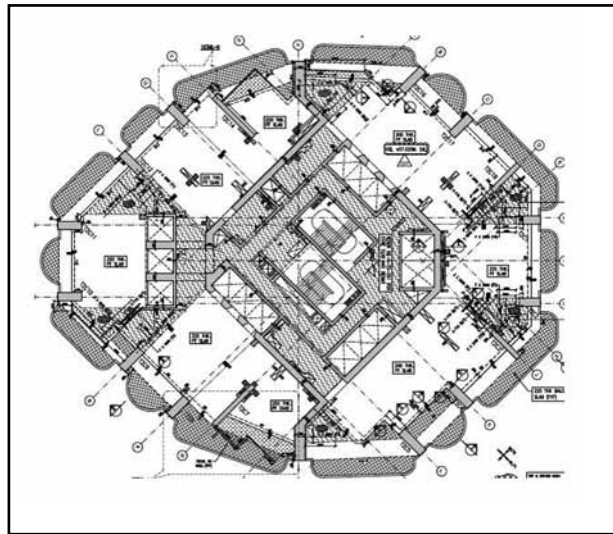

Damac Heights, Dubai Marina, UAE



Image: U+A Architects.

PROJECT DESCRIPTION

STRUCTURAL SYSTEM: Central core with fan walls

TYPE/ OCCUPANCY: Residential

STOREYS/HEIGHT: 86 storeys – 335 m.

FLOOR AREA: Total built-up area 130,000 m²

COST: AED750M.

COMPLETION DATE: estimated: 2016

This tall building is located in Dubai Marina, an area with a number of tall and super-tall buildings.

The foundations are a piled raft and 3.5 m thick. There are 5 basement levels that total 18 m in depth. The stability for this tall building comes from a central core with fan walls, and the fan walls are transferred at the podium level. The podium level, basements and ground floor use reinforced concrete slabs and mainly flat slabs.

In the tower the residential floors use post-tensioned concrete construction and on the remaining floors, RC slabs and beams are used. The walls vary from 250 mm to 850 mm thick, the columns vary from 1,800x800 mm to 1,200x400 mm and the circular columns from 600 mm to 1,300 mm in diameter. The concrete was C60 to C50 for horizontal elements and C80 to C50 for vertical elements.

PROJECT TEAM

CLIENT: Damac Gulf Properties LLC

ARCHITECT: Aedas, U+A Architects

STRUCTURAL ENGINEER: Ramboll Middle East

M&E: Ramboll Middle East

MAIN CONTRACTOR: Arabtec

FRAME CONTRACTOR: Arabtec

Floor plate.

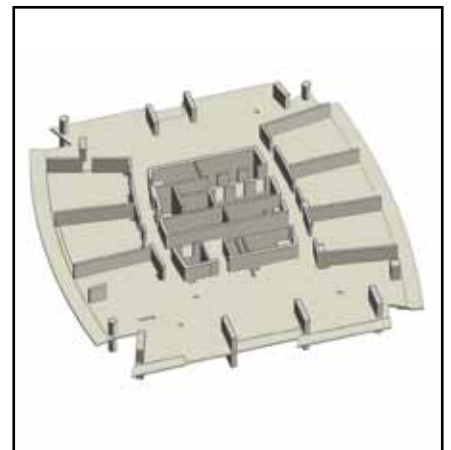
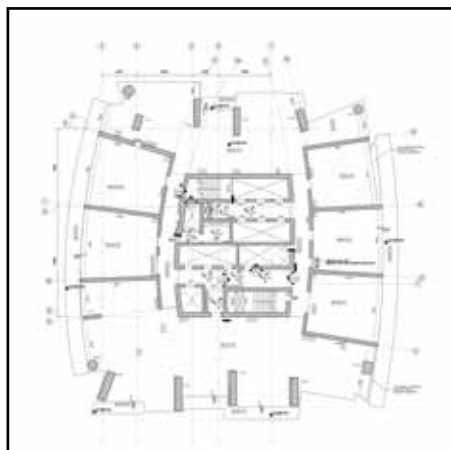

The Shard, London, UK



PROJECT DESCRIPTION

STRUCTURAL SYSTEM: RC core with hat truss

TYPE/ OCCUPANCY: Office/Residential/Hotel

STOREYS/HEIGHT: 87 storeys – 306 m

FLOOR AREA: 120,700 m²

COMPLETION DATE: 2013

This iconic, mixed-use development is located on the south bank of the Thames near to London Bridge. It provides 55,000 m² of office space on 25 floors, three floors of restaurants, a 17-storey hotel, 13 floors of apartments and a triple-height viewing gallery, as well as an open-air viewing floor on level 72.

The stability system is a reinforced concrete core with a high level “hat truss” to engage the external columns so as to control acceleration. The columns are a mixture of concrete and steel with high-strength C65/80 concrete used at the bottom. The walls are 250 mm – 800 mm thick and also use high-strength C65/80 concrete at the bottom.

There are three basement levels and the foundations consist of a secant piled perimeter wall and piled raft. Top down construction was used to construct the core and the foundations.

The floors are composite floor on steel beams up to level 40 and then 200 -250 mm thick post-tensioned slabs from levels 41 to 69. The top spire levels are formed by a steel frame. The concrete for the horizontal elements is C32/40.

At the time of publishing it is the tallest building in the UK, and when completed it was the tallest building in Western Europe.

PROJECT TEAM

Client: Sellar Property Group in partnership with the State of Qatar

Architect: Renzo Piano Building Workshop with Adamsons Associates

Structural Engineer: WSP

M&E: Arup

Main Contractor: Mace

Concrete Frame Contractor: Byrne Bros.

Hat truss.

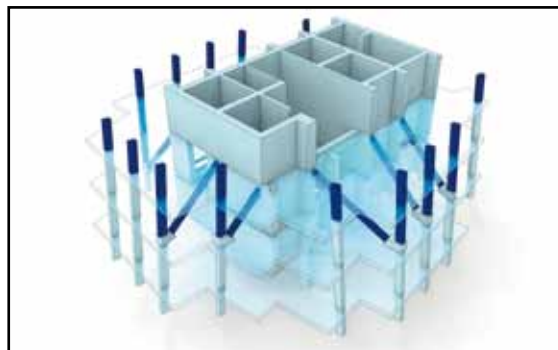

Working Group

Convenor: Andy Truby (TrubyStevenson Ltd)

Authors: Colin Banks (Laing O'Rourke)
Jenny Burridge (The Concrete Centre)
Stefano Cammelli (BMT Fluid Mechanics Limited)
Mario A Chiorino (Politecnico of Torino, Italy)
Taehun Ha (Daewoo Engineering and Construction)
Jean-Marc Jaeger (Setec TPI)
George Keleris (Buro Happold)
Stuart Marsh (Skidmore Owings & Merrill)
Jose Romo (FHECOR)
Steve McKechnie (Arup)
Andy Truby (TrubyStevenson Ltd)
Jeremy Wells (WSP)

Other Contributors: Stuart Alexander (WSP)
Barry Crisp (Hollow Core Concrete, Australia)
David Horos (Skidmore Owings & Merrill)
Harald Rosendahl (Bubbledeck, Norway)
David Scott (Laing O'Rourke)
David Vesey (Arup)
Brad Young (Skidmore Owings & Merrill)

Tall Buildings

The primary aim of this publication is to provide guidance on the design and construction of tall concrete buildings. The guidance is intended to assist engineers in understanding the common challenges and pitfalls associated with transferring standard engineering principles and knowledge from low-rise structures to tall buildings.

This guide was authored by *fib* task group 1.6 and published by a working group from The Concrete Centre and the *fib*. Both groups were chaired by Andy Truby, formerly of Ramboll and presently of TrubyStevenson.

This guide has been published jointly by the *fib* and The Concrete Centre and is also available as *fib* Bulletin 73. Readers can access more information at:

www.concretecentre.com
www.fib-international.org
www.fibuk.org

CCIP-058

Published September 2014

ISBN 978-1-908257-14-7

Price Group R

© MPA The Concrete Centre and Fédération internationale du béton (*fib*)

Gillingham House,
38-44 Gillingham Street, London, SW1V 1HU

Tel: +44 (0)207 963 8000

www.concretecentre.com